



32K × 8 HIGH SPEED CMOS STATIC RAM

GENERAL DESCRIPTION

The W24257A is a high speed, low power CMOS static RAM organized as 32768 × 8 bits that operates on a single 5-volt power supply. This device is manufactured using Winbond's high performance CMOS technology.

FEATURES

- High speed access time: 10/12/15/20 nS (max.)
- Low power consumption:
 - Active: 400 mW (typ.)
- Single +5V power supply
- Fully static operation
- All inputs and outputs directly TTL compatible
- Three-state outputs
- Available packages: 28-pin 300 mil SOJ, 330 mil SOP, skinny DIP and standard type one TSOP (8 mm × 13.4 mm)

PIN CONFIGURATIONS

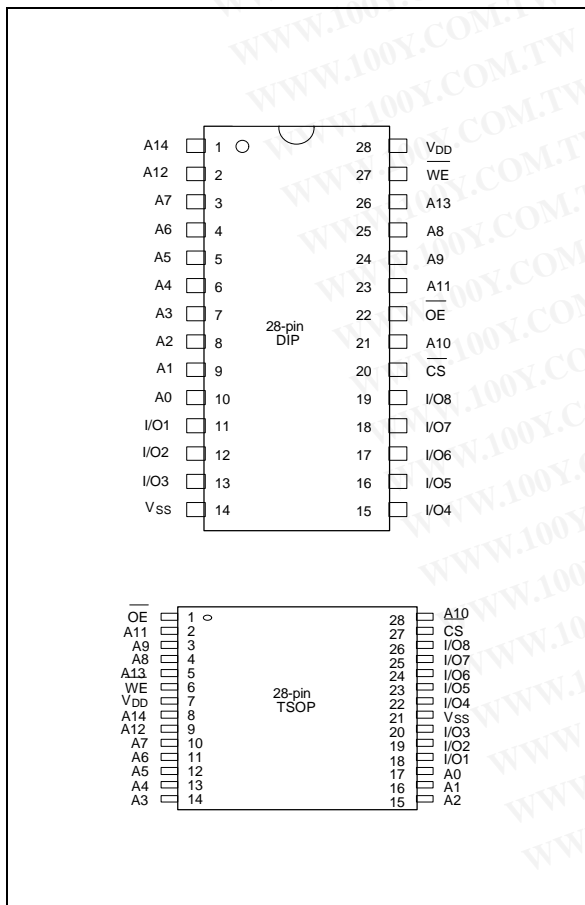

BLOCK DIAGRAM

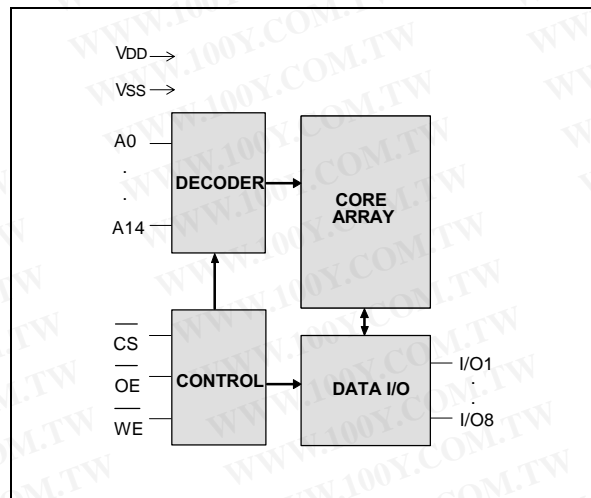

PIN DESCRIPTION

SYMBOL	DESCRIPTION
A0–A14	Address Inputs
I/O1–I/O8	Data Inputs/Outputs
$\overline{\text{CS}}$	Chip Select Input
$\overline{\text{WE}}$	Write Enable Input
$\overline{\text{OE}}$	Output Enable Input
VDD	Power Supply
VSS	Ground



DC CHARACTERISTICS

Absolute Maximum Ratings

PARAMETER	RATING	UNIT
Supply Voltage to Vss Potential	-0.5 to +7.0	V
Input/Output to Vss Potential	-0.5 to VDD +0.5	V
Allowable Power Dissipation	1.0	W
Storage Temperature	-65 to +150	°C
Operating Temperature	0 to +70	°C

Note: Exposure to conditions beyond those listed under Absolute Maximum Ratings may adversely affect the life and reliability of the device.

TRUTH TABLE

\overline{CS}	\overline{OE}	\overline{WE}	MODE	I/O1-I/O8	VDD CURRENT
H	X	X	Not Selected	High Z	ISB, ISB1
L	H	H	Output Disable	High Z	IDD
L	L	H	Read	Data Out	IDD
L	X	L	Write	Data In	IDD

OPERATING CHARACTERISTICS

(VDD = 5V ±10%, Vss = 0V, TA = 0 to 70° C)

PARAMETER	SYM.	TEST CONDITIONS	MIN.	TYP.	MAX.	UNIT	
Input Low Voltage	VIL	-	-0.5	-	+0.8	V	
Input High Voltage	VIH	-	+2.2	-	VDD +0.5	V	
Input Leakage Current	ILI	VIN = Vss to VDD	-10	-	+10	μA	
Output Leakage Current	ILO	VIO = Vss to VDD, \overline{CS} = VIH or \overline{OE} = VIH or \overline{WE} = VIL	-10	-	+10	μA	
Output Low Voltage	VOL	IOL = +8.0 mA	-	-	0.4	V	
Output High Voltage	VOH	IOH = -4.0 mA	2.4	-	-	V	
Operating Power Supply Current	IDD	\overline{CS} = VIL, I/O = 0 mA Cycle = MIN Duty = 100%	10	-	-	170	mA
			12	-	-	160	mA
			15	-	-	150	mA
			20	-	-	140	mA
Standby Power Supply Current	ISB	\overline{CS} = VIH Cycle = MIN, Duty = 100%	-	-	30	mA	
	ISB1	\overline{CS} ≥ VDD -0.2V	-	-	10	mA	

Note: Typical characteristics are at VDD = 5V, TA = 25° C.

勝特力材料 886-3-5753170
 勝特力电子(上海) 86-21-54151736
 勝特力电子(深圳) 86-755-83298787
 Http://www.100y.com.tw

W24257A



CAPACITANCE

(V_{DD} = 5V, T_A = 25° C, f = 1 MHz)

PARAMETER	SYM.	CONDITIONS	MAX.	UNIT
Input Capacitance	C _{IN}	V _{IN} = 0V	8	pF
Input/Output Capacitance	C _{I/O}	V _{OUT} = 0V	10	pF

Note: These parameters are sampled but not 100% tested.

THERMAL RESISTANCE

PARAMETER	SYM	CONDITIONS	MAX.	UNIT
Junction to Case Thermal Resistance	θ _{JC}	A. F. R. = 1m/sec, T _A = 25° C	20	°C/W
Junction to Ambient Thermal Resistance	θ _{JA}	A. F. R. = 1m/sec, T _A = 25° C	60	°C/W

Note: These parameters are only applied to "TSOP" and "SOJ" package types.

AC TEST CONDITIONS

PARAMETER	CONDITIONS
Input Pulse Levels	0V to 3V
Input Rise and Fall Times	5 nS
Input and Output Timing Reference Level	1.5V
Output Load	C _L = 30 pF, I _{OH} /I _{OL} = -4 mA/8 mA

勝特力材料 886-3-5753170
勝特力电子(上海) 86-21-54151736
勝特力电子(深圳) 86-755-83298787
[Http://www.100y.com.tw](http://www.100y.com.tw)

W24257A



AC TEST LOADS AND WAVEFORM

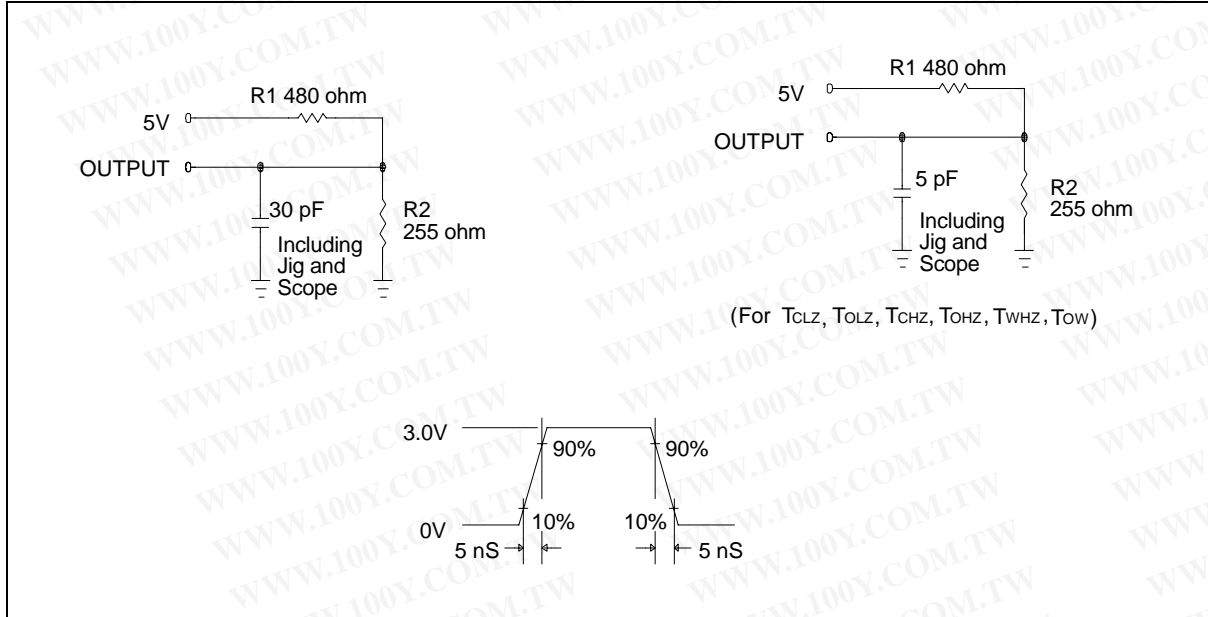

勝特力材料 886-3-5753170
 勝特力电子(上海) 86-21-54151736
 勝特力电子(深圳) 86-755-83298787
[Http://www.100y.com.tw](http://www.100y.com.tw)

W24257A



AC CHARACTERISTICS

(V_{DD} = 5V ±10%, V_{SS} = 0V, T_A = 0 to 70° C)

Read Cycle

PARAMETER	SYM.	W24257A-10		W24257A-12		W24257A-15		W24257A-20		UNIT
		MIN.	MAX.	MIN.	MAX.	MIN.	MAX.	MIN.	MAX.	
Read Cycle Time	T _{RC}	10	-	12	-	15	-	20	-	nS
Address Access Time	T _{AA}	-	10	-	12	-	15	-	20	nS
Chip Select Access Time	T _{ACS}	-	10	-	12	-	15	-	20	nS
Output Enable to Output Valid	T _{AOE}	-	5	-	6	-	7	-	10	nS
Chip Selection to Output in Low Z	T _{CLZ} *	3	-	3	-	3	-	3	-	nS
Output Enable to Output in Low Z	T _{OLZ} *	0	-	0	-	0	-	0	-	nS
Chip Deselection to Output in High Z	T _{CHZ} *	-	5	-	6	-	7	-	10	nS
Output Disable to Output in High Z	T _{OHZ} *	-	5	-	6	-	7	-	10	nS
Output Hold from Address Change	T _{OH}	3	-	3	-	3	-	3	-	nS

* These parameters are sampled but not 100% tested.

Write Cycle

PARAMETER	SYM.	W24257A-10		W24257A-12		W24257A-15		W24257A-20		UNIT
		MIN.	MAX.	MIN.	MAX.	MIN.	MAX.	MIN.	MAX.	
Write Cycle Time	T _{WC}	10	-	12	-	15	-	20	-	nS
Chip Selection to End of Write	T _{CW}	9	-	10	-	13	-	17	-	nS
Address Valid to End of Write	T _{AW}	9	-	10	-	13	-	17	-	nS
Address Setup Time	T _{AS}	0	-	0	-	0	-	0	-	nS
Write Pulse Width	T _{WP}	9	-	10	-	10	-	12	-	nS
Write Recovery Time	T _{WR}	0	-	0	-	0	-	0	-	nS
	CS, WE									
Data Valid to End of Write	T _{DW}	6	-	7	-	9	-	10	-	nS
Data Hold from End of Write	T _{DH}	0	-	0	-	0	-	0	-	nS
Write to Output in High Z	T _{WHZ} *	-	6	-	7	-	8	-	10	nS
Output Disable to Output in High Z	T _{OHZ} *	-	6	-	7	-	8	-	10	nS
Output Active from End of Write	T _{OW}	0	-	0	-	0	-	0	-	nS

* These parameters are sampled but not 100% tested.



TIMING WAVEFORMS

Read Cycle 1

(Address Controlled)

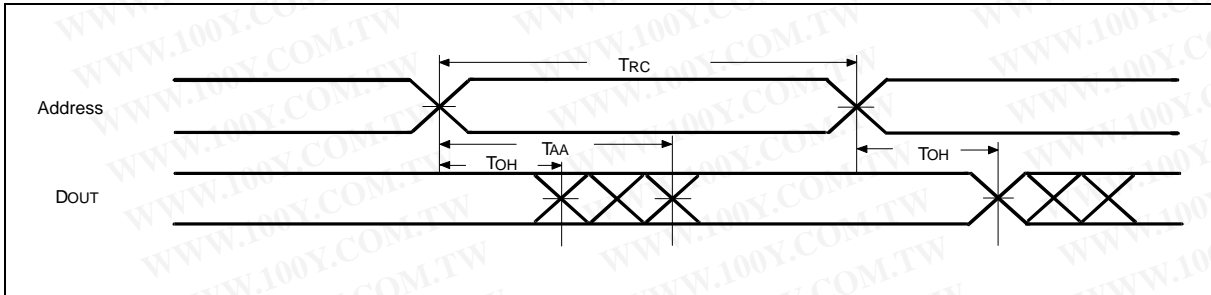

Read Cycle 2

(Chip Select Controlled)

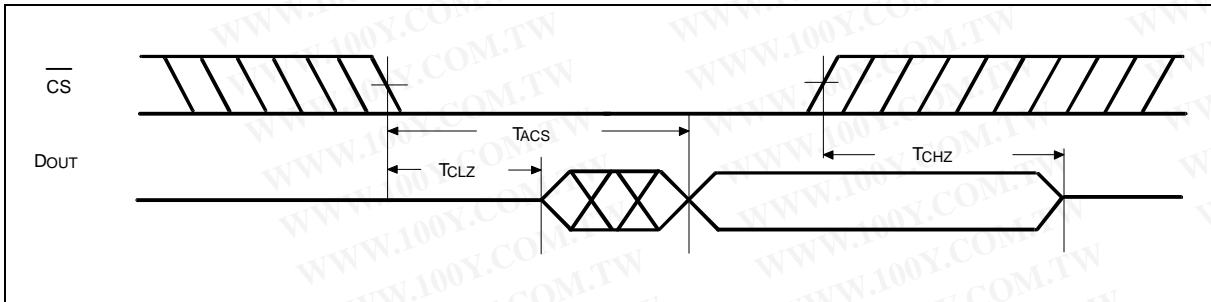

Read Cycle 3

(Output Enable Controlled)

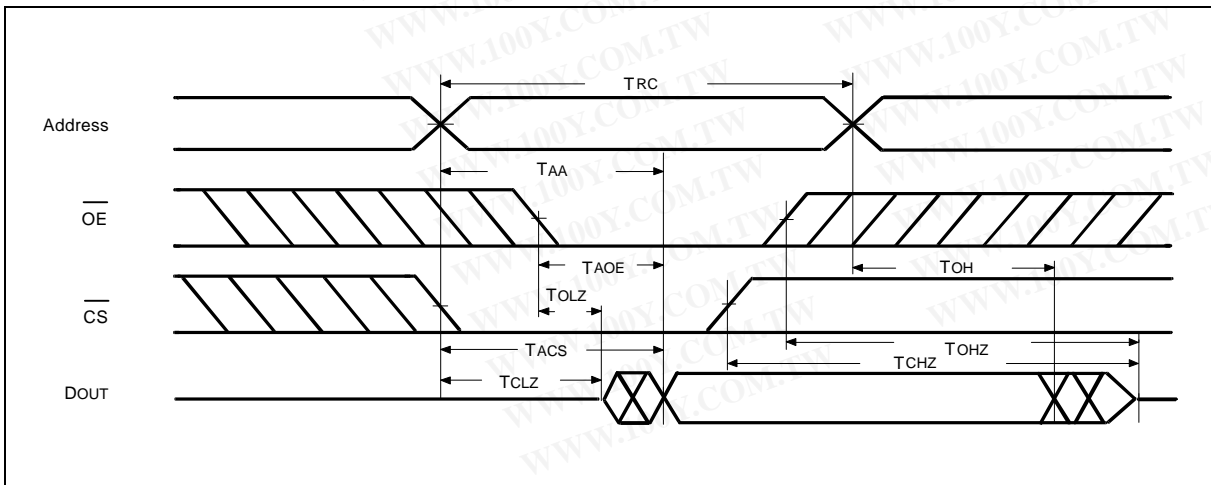

Timing Waveforms, continued

Write Cycle 1 (OE Clock)

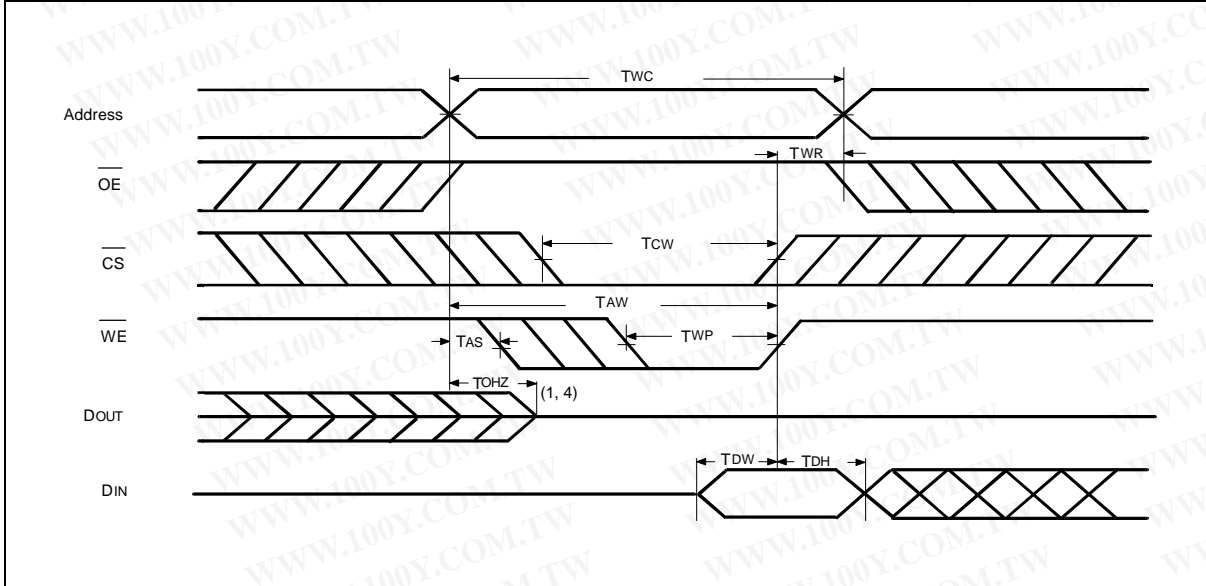

Write Cycle 2 (\overline{OE} = VIL Fixed)

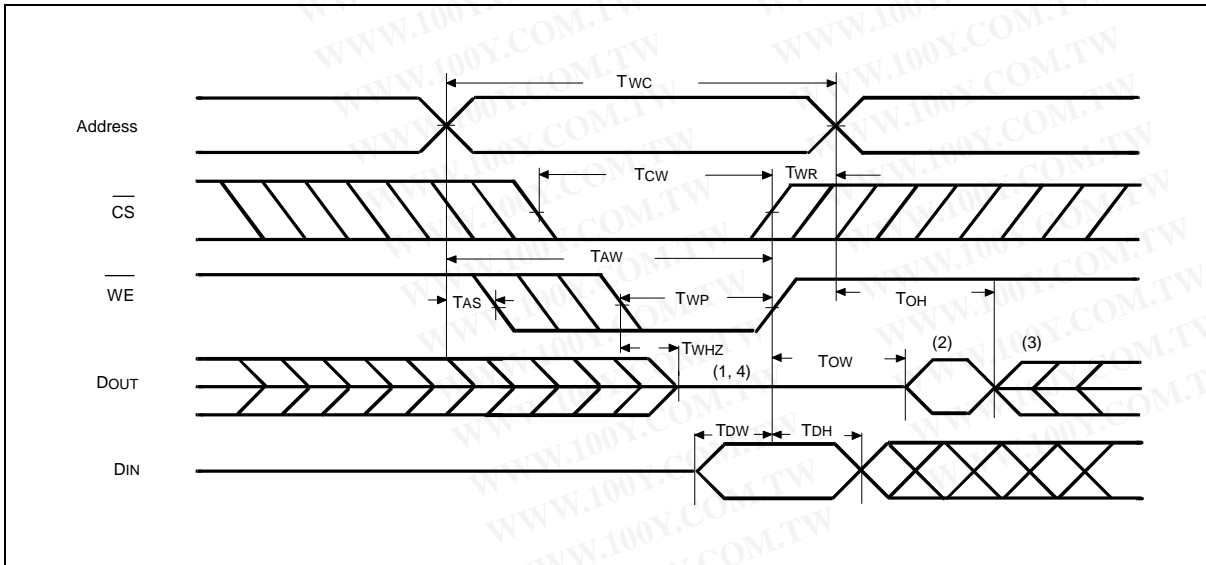

Notes:

1. During this period, I/O pins are in the output state, so input signals of opposite phase to the outputs should not be applied.
2. The data output from DOUT are the same as the data written to DIN during the write cycle.
3. DOUT provides the read data for the next address.
4. Transition is measured ± 500 mV from steady state with $C_L = 5$ pF. This parameter is guaranteed but not 100% tested.



勝特力材料 886-3-5753170
勝特力电子(上海) 86-21-54151736
勝特力电子(深圳) 86-755-83298787
[Http://www.100y.com.tw](http://www.100y.com.tw)

W24257A

ORDERING INFORMATION

PART NO.	ACCESS TIME (nS)	OPERATING CURRENT MAX. (mA)	STANDBY CURRENT MAX. (mA)	PACKAGE
W24257AK-10	10	170	10	300 mil skinny DIP
W24257AK-12	12	160	10	300 mil skinny DIP
W24257AK-15	15	150	10	300 mil skinny DIP
W24257AK-20	20	140	10	300 mil skinny DIP
W24257AJ-10	10	170	10	300 mil SOJ
W24257AJ-12	12	160	10	300 mil SOJ
W24257AJ-15	15	150	10	300 mil SOJ
W24257AJ-20	20	140	10	300 mil SOJ
W24257AS-10	10	170	10	330 mil SOP
W24257AS-12	12	160	10	330 mil SOP
W24257AS-15	15	150	10	330 mil SOP
W24257AS-20	20	140	10	330 mil SOP
W24257AQ-10	10	170	10	Standard type one TSOP
W24257AQ-12	12	160	10	Standard type one TSOP
W24257AQ-15	15	150	10	Standard type one TSOP
W24257AQ-20	20	140	10	Standard type one TSOP

Notes:

1. Winbond reserves the right to make changes to its products without prior notice.
2. Purchasers are responsible for performing appropriate quality assurance testing on products intended for use in applications where personal injury might occur as a consequence of product failure.



PACKAGE DIMENSIONS

28-pin P-DIP Skinny

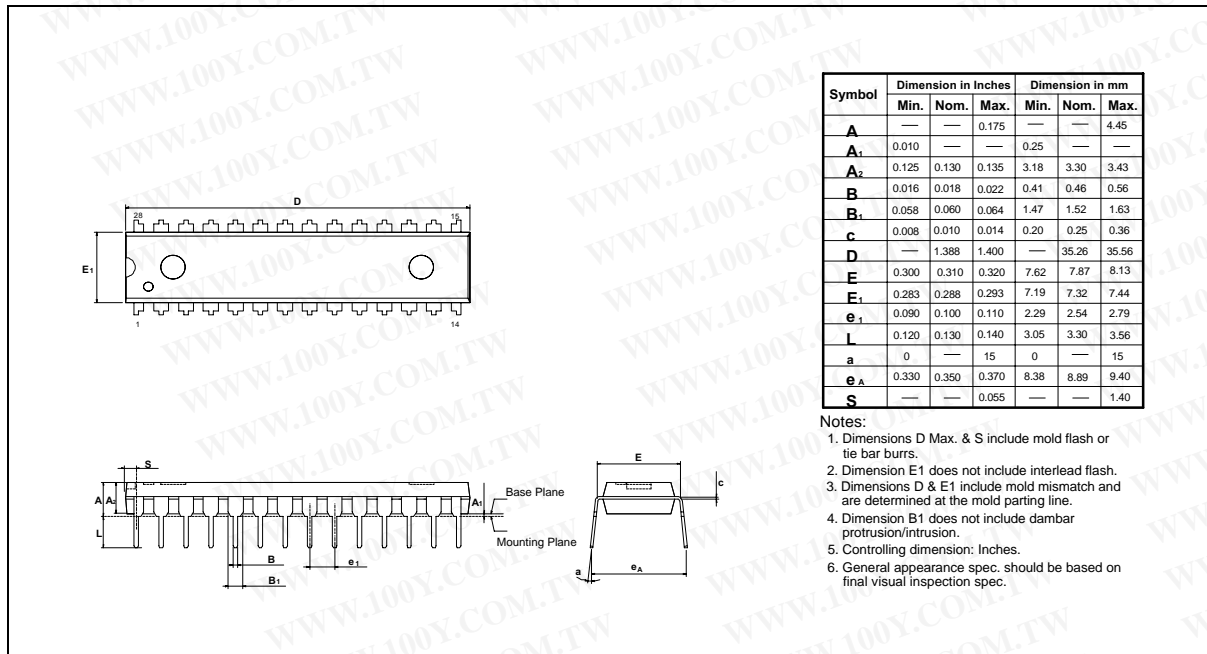

28-pin Small Outline J Band

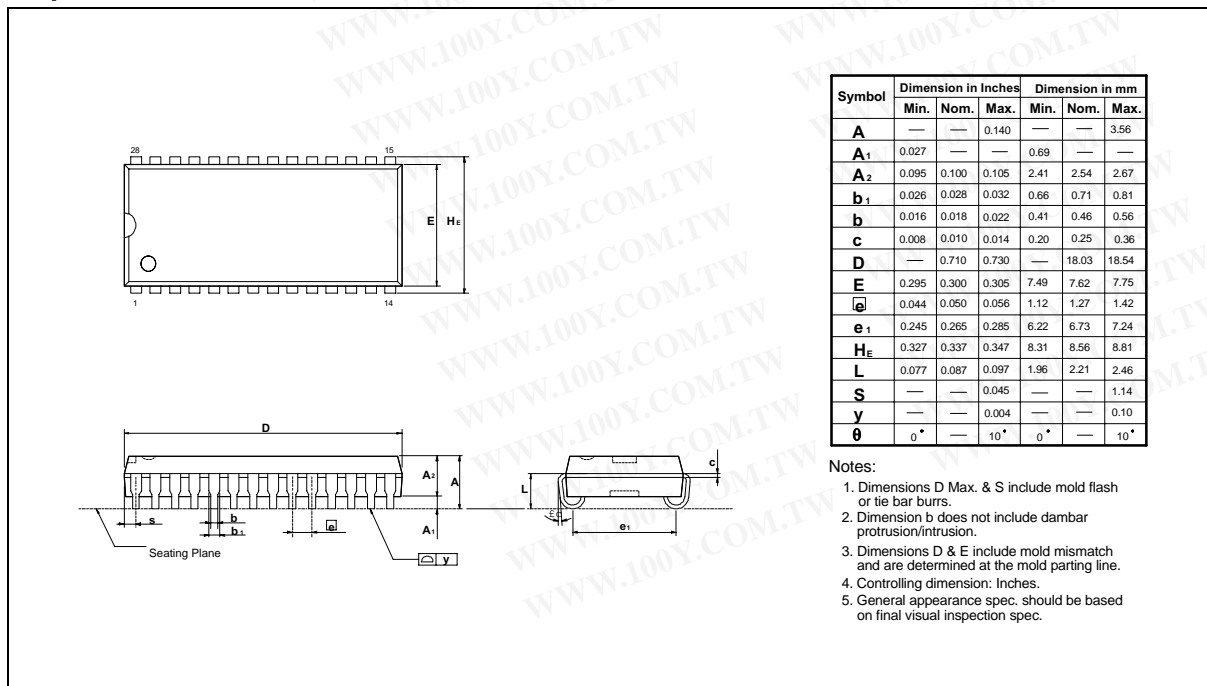

Package Dimensions, continued

28-pin SO Wide Body

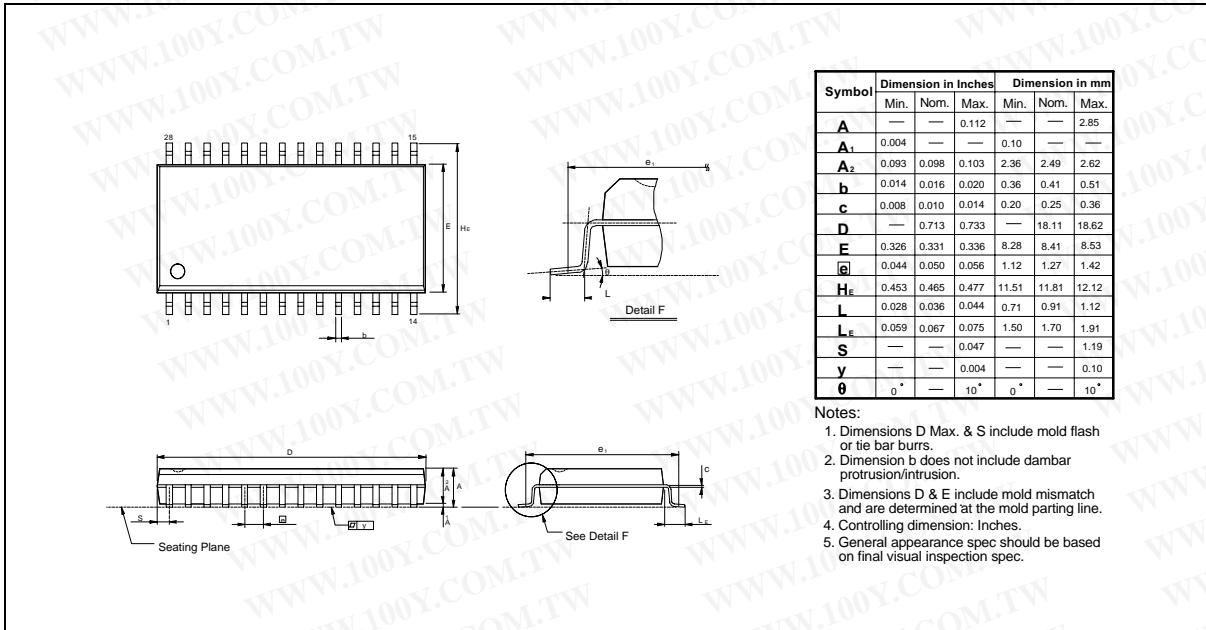

28-pin Standard Type One TSOP

