

UTC 79LXX LINEAR INTEGRATED CIRCUIT

3-TERMINAL 0.1A NEGATIVE VOLTAGE REGULATOR

DESCRIPTION

The UTC 79LXX family is monolithic fixed voltage regulator integrated circuit. They are suitable for applications that required supply current up to 100mA.

FEATURES

- *Output current up to 100mA
- *Fixed output voltage of -5V, -6V, -8V, -9V, -12V, -15V, -18V and -24V available
- *Thermal overload shutdown protection
- *Short circuit current limiting

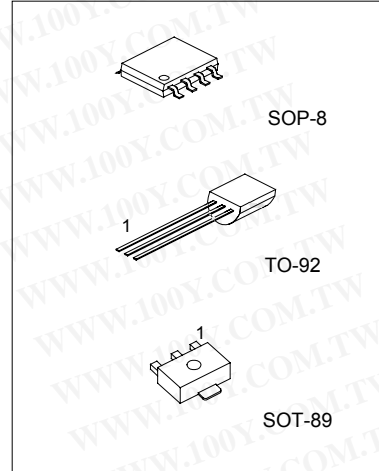

SOP-8 : 1. Vout ; 2,3,6,7 Vin ; 5. GND; 4,8 NC

TO-92 : 1: GND 2: Input 3: Output

SOT-89: 1: GND 2: Input 3: Output

*Pb-free plating product number: 79LXXL

ORDERING INFORMATION

| Order Number | | Package | Packing |
|--------------|--------------|---------|-----------|
| Normal | Lead free | | |
| 79Lxx-S08-R | 79LxxL-S08-R | SOP-8 | Tape Reel |
| 79Lxx-S08-T | 79LxxL-S08-T | SOP-8 | Tube |
| 79Lxx-AB3-R | 79LxxL-AB3-R | SOT-89 | Tape Reel |
| 79Lxx-T92-B | 79LxxL-T92-B | TO-92 | Tape Box |
| 79Lxx-T92-K | 79LxxL-T92-K | TO-92 | Bulk |

Note:1. xx: Output Voltage, refer to Marking Information.

勝特力材料 886-3-5753170
 勝特力电子(上海) 86-21-54151736
 勝特力电子(深圳) 86-755-83298787
[Http://www.100y.com.tw](http://www.100y.com.tw)

UTC 79LXX

LINEAR INTEGRATED CIRCUIT

TEST CIRCUIT

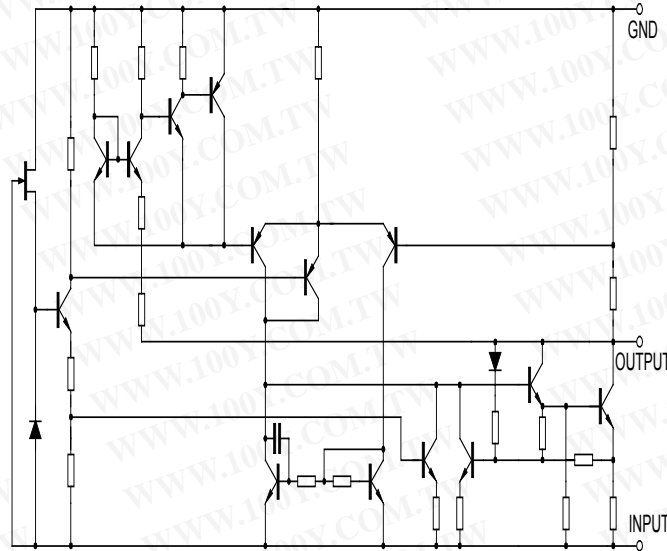

ABSOLUTE MAXIMUM RATINGS (Operating temperature range applies unless otherwise specified)

| PARAMETER | SYMBOL | VALUE | UNIT |
|--|-----------|--|------|
| Input voltage (for $V_o = -5 \sim -9V$) (for $V_o = -12 \sim -15V$) (for $V_o = -18 \sim -24V$) | V_i | -30 | V |
| | V_i | -35 | V |
| | V_i | | |
| Power Dissipation | P_d | 350 (SOT-89) 300 (SOP-8) 625 (TO-92) | mW |
| Operating Junction Temperature Range | T_{opr} | -30 ~ +125 | °C |
| Storage Temperature Range | T_{stg} | -40 ~ +125 | °C |

勝特力材料 886-3-5753170
 勝特力电子(上海) 86-21-54151736
 勝特力电子(深圳) 86-755-83298787
[Http://www.100y.com.tw](http://www.100y.com.tw)

UTC

UNISONIC TECHNOLOGIES CO., LTD.

2

QW-R101-003,E

UTC 79LXX LINEAR INTEGRATED CIRCUIT

UTC79L05 ELECTRICAL CHARACTERISTICS

(T_J=25°C, C₁=0.33μF, C_o=0.1μF, unless otherwise specified)

| PARAMETER | SYMBOL | TEST CONDITIONS | MIN | TYP | MAX | UNIT |
|----------------------|---------------------------------|--|------|------|------|------|
| Output Voltage | V _o | V _{IN} =-10V, I _o =40mA | -4.8 | -5.0 | -5.2 | V |
| Line Regulation | V _o -V _{IN} | V _{IN} =-7~-20V, I _o =40mA | | 15 | 150 | mV |
| Load Regulation | V _o -I _o | V _{IN} =-10V, I _o =1~100mA | | 7 | 60 | mV |
| Quiescent current | I _q | V _{IN} =-10V, I _o =40mA | | 3.5 | 6.0 | mA |
| Ripple Rejection | RR | V _{IN} =-8~-18V, I _o =40mA, E _{in} =1Vp-p, f=120Hz | 41 | 71 | | dB |
| Output Noise Voltage | V _{NO} | V _{IN} =-10V, BW=10Hz~100kHz, I _o =40mA | | 120 | | μV |

UTC79L06 ELECTRICAL CHARACTERISTICS

(T_J=25°C, C₁=0.33μF, C_o=0.1μF, unless otherwise specified)

| PARAMETER | SYMBOL | TEST CONDITIONS | MIN | TYP | MAX | UNIT |
|----------------------|---------------------------------|--|-------|------|-------|------|
| Output Voltage | V _o | V _{IN} =-12V, I _o =40mA | -5.76 | -6.0 | -6.24 | V |
| Line Regulation | V _o -V _{IN} | V _{IN} =-8.5~-20V, I _o =40mA | | 15 | 150 | mV |
| Load Regulation | V _o -I _o | V _{IN} =-12V, I _o =1~100mA | | 7 | 60 | mV |
| Quiescent current | I _q | V _{IN} =-12V, I _o =40mA | | 3.5 | 6.0 | mA |
| Ripple Rejection | RR | V _{IN} =-9~-19V, I _o =40mA, E _{in} =1Vp-p, f=120Hz | 41 | 71 | | dB |
| Output Noise Voltage | V _{NO} | V _{IN} =-12V, BW=10Hz~100kHz, I _o =40mA | | 120 | | μV |

UTC79L08 ELECTRICAL CHARACTERISTICS

(T_J=25°C, C₁=0.33μF, C_o=0.1μF, unless otherwise specified)

| PARAMETER | SYMBOL | Test conditions | MIN | TYP | MAX | UNIT |
|----------------------|---------------------------------|---|-------|------|-------|------|
| Output Voltage | V _o | V _{IN} =-14V, I _o =40mA | -7.68 | -8.0 | -8.32 | V |
| Line Regulation | V _o -V _{IN} | V _{IN} =-10.5~-23V, I _o =40mA | | 24 | 175 | mV |
| Load Regulation | V _o -I _o | V _{IN} =-14V, I _o =1~100mA | | 10 | 80 | mV |
| Quiescent current | I _q | V _{IN} =-14V, I _o =40mA | | 3.5 | 6.0 | mA |
| Ripple Rejection | RR | V _{IN} =-11~-21V, I _o =40mA, E _{in} =1Vp-p, f=140Hz | 39 | 68 | | dB |
| Output Noise Voltage | V _{NO} | V _{IN} =-14V, BW=10Hz~100kHz, I _o =40mA | | 190 | | μV |

UTC79L09 ELECTRICAL CHARACTERISTICS

(T_J=25°C, C₁=0.33μF, C_o=0.1μF, unless otherwise specified)

| PARAMETER | SYMBOL | TEST CONDITIONS | MIN | TYP | MAX | UNIT |
|----------------------|---------------------------------|---|-------|------|-------|------|
| Output Voltage | V _o | V _{IN} =-15V, I _o =40mA | -8.64 | -9.0 | -9.36 | V |
| Line Regulation | V _o -V _{IN} | V _{IN} =-12.5~-24V, I _o =40mA | | 27 | 200 | mV |
| Load Regulation | V _o -I _o | V _{IN} =-15V, I _o =1~100mA | | 12 | 90 | mV |
| Quiescent current | I _q | V _{IN} =-15V, I _o =40mA | | 3.5 | 6.0 | mA |
| Ripple Rejection | RR | V _{IN} =-12~-22V, I _o =40mA, E _{in} =1Vp-p, f=150Hz | 37 | 64 | | dB |
| Output Noise Voltage | V _{NO} | V _{IN} =-15V, BW=10Hz~100kHz, I _o =40mA | | 210 | | μV |

UTC UNISONIC TECHNOLOGIES CO., LTD. 3

QW-R101-003,E

勝特力材料 886-3-5753170
 勝特力电子(上海) 86-21-54151736
 勝特力电子(深圳) 86-755-83298787
[Http://www.100y.com.tw](http://www.100y.com.tw)

UTC79LXX LINEAR INTEGRATED CIRCUIT

UTC79L12 ELECTRICAL CHARACTERISTICS

(T_J=25°C, C₁=0.33μF, C_o=0.1μF, unless otherwise specified)

| PARAMETER | SYMBOL | TEST CONDITIONS | MIN | TYP | MAX | UNIT |
|----------------------|---------------------------------|---|--------|-------|--------|------|
| Output Voltage | V _o | V _{IN} =-19V, I _o =40mA | -11.52 | -12.0 | -12.48 | V |
| Line Regulation | V _o -V _{IN} | V _{IN} =-14.5~-27V, I _o =40mA | | 36 | 250 | mV |
| Load Regulation | V _o -I _o | V _{IN} =-19V, I _o =1~100mA | | 16 | 100 | mV |
| Quiescent current | I _q | V _{IN} =-19V, I _o =40mA | | 3.5 | 6.0 | mA |
| Ripple Rejection | RR | V _{IN} =-15~-25V, I _o =40mA, E _{in} =1Vp-p, f=190Hz | 37 | 64 | | dB |
| Output Noise Voltage | V _{NO} | V _{IN} =-19V, BW=10Hz~100kHz, I _o =40mA | | 210 | | μV |

UTC79L15 ELECTRICAL CHARACTERISTICS

(T_J=25°C, C₁=0.33μF, C_o=0.1μF, unless otherwise specified)

| PARAMETER | SYMBOL | TEST CONDITIONS | MIN | TYP | MAX | UNIT |
|----------------------|---------------------------------|---|-------|-------|-------|------|
| Output Voltage | V _o | V _{IN} =-23V, I _o =40mA | -14.4 | -15.0 | -15.6 | V |
| Line Regulation | V _o -V _{IN} | V _{IN} =-17.5~-30V, I _o =40mA | | 45 | 300 | mV |
| Load Regulation | V _o -I _o | V _{IN} =-23V, I _o =1~100mA | | 20 | 150 | mV |
| Quiescent current | I _q | V _{IN} =-23V, I _o =40mA | | 3.5 | 6.0 | mA |
| Ripple Rejection | RR | V _{IN} =-18.5~-28.5V, I _o =40mA, E _{in} =1Vp-p, f=230Hz | 34 | 63 | | dB |
| Output Noise Voltage | V _{NO} | V _{IN} =-23V, BW=10Hz~100kHz, I _o =40mA | | 340 | | μV |

UTC79L18 ELECTRICAL CHARACTERISTICS

(T_J=25°C, C₁=0.33μF, C_o=0.1μF, unless otherwise specified)

| PARAMETER | SYMBOL | TEST CONDITIONS | MIN | TYP | MAX | UNIT |
|----------------------|---------------------------------|---|--------|-------|--------|------|
| Output Voltage | V _o | V _{IN} =-27V, I _o =40mA | -17.28 | -18.0 | -18.72 | V |
| Line Regulation | V _o -V _{IN} | V _{IN} =-20.5~-33V, I _o =40mA | | 54 | 300 | mV |
| Load Regulation | V _o -I _o | V _{IN} =-27V, I _o =1~100mA | | 23 | 170 | mV |
| Quiescent current | I _q | V _{IN} =-27V, I _o =40mA | | 3.5 | 6.0 | mA |
| Ripple Rejection | RR | V _{IN} =-23~-33V, I _o =40mA, E _{in} =1Vp-p, f=270Hz | 33 | 60 | | dB |
| Output Noise Voltage | V _{NO} | V _{IN} =-27V, BW=10Hz~100kHz, I _o =40mA | | 410 | | μV |

UTC79L24 ELECTRICAL CHARACTERISTICS

(T_J=25°C, C₁=0.33μF, C_o=0.1μF, unless otherwise specified)

| PARAMETER | SYMBOL | TEST CONDITIONS | MIN | TYP | MAX | UNIT |
|----------------------|---------------------------------|---|--------|-------|--------|------|
| Output Voltage | V _o | V _{IN} =-33V, I _o =40mA | -23.04 | -24.0 | -24.96 | V |
| Line Regulation | V _o -V _{IN} | V _{IN} =-27~-38V, I _o =40mA | | 72 | 350 | mV |
| Load Regulation | V _o -I _o | V _{IN} =-33V, I _o =1~100mA | | 30 | 200 | mV |
| Quiescent current | I _q | V _{IN} =-33V, I _o =40mA | | 3.5 | 6.0 | mA |
| Ripple Rejection | RR | V _{IN} =-29~-35V, I _o =40mA, E _{in} =1Vp-p, f=330Hz | 31 | 55 | | dB |
| Output Noise Voltage | V _{NO} | V _{IN} =-33V, BW=10Hz~100kHz, I _o =40mA | | 550 | | μV |

UTC UNISONIC TECHNOLOGIES CO., LTD.

4

QW-R101-003,E

勝特力材料 886-3-5753170
 勝特力电子(上海) 86-21-54151736
 勝特力电子(深圳) 86-755-83298787
[Http://www.100y.com.tw](http://www.100y.com.tw)

UTC79LXX LINEAR INTEGRATED CIRCUIT

APPLICATION CIRCUIT

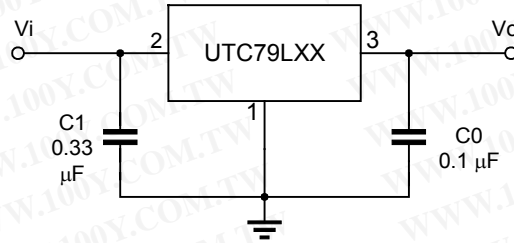

勝特力材料 886-3-5753170
勝特力电子(上海) 86-21-54151736
勝特力电子(深圳) 86-755-83298787
[Http://www.100y.com.tw](http://www.100y.com.tw)

UTC79LXX LINEAR INTEGRATED CIRCUIT

TYPICAL PERFORMANCE CHARACTERISTICS

Fig.1 Power dissipation vs. ambient temperature

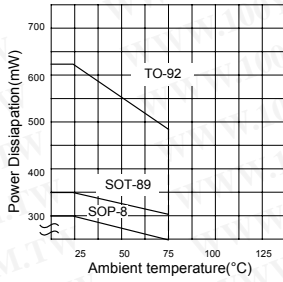

Fig.2 Input Voltage vs. Output Voltage

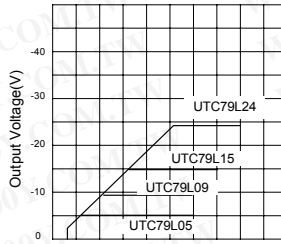

Fig.3 Load Characteristics (T_J=25°C)

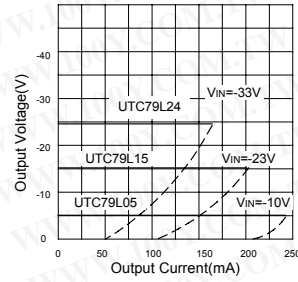

Fig.4 Short Circuit Current (T_J=25°C)

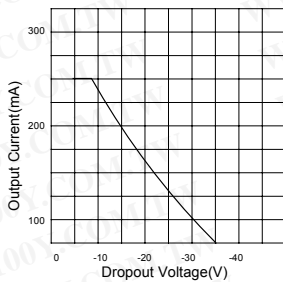

Fig.5 Output Voltage vs. Junction temperature

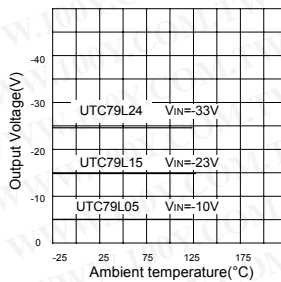

Fig.6 Output Voltage vs. ambient temperature

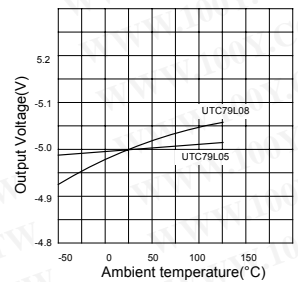

Fig.7 UTC79L05 Dropout Characteristics (T_J=25°C)

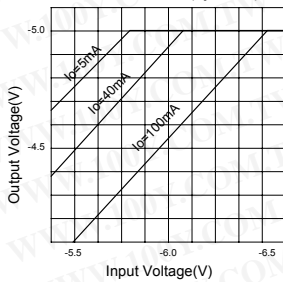

Fig.8 UTC79L08 Dropout Characteristics (T_J=25°C)

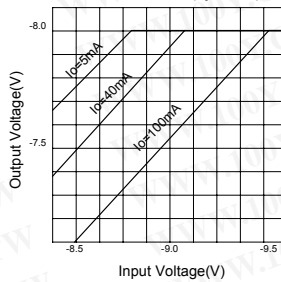
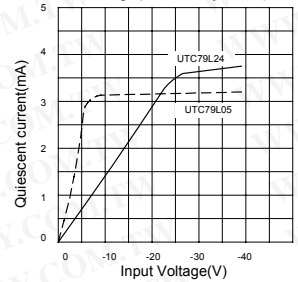

Fig.9 Current vs. Input Voltage (I_O=0mA, T_J=25°C)



UTC 79LXX LINEAR INTEGRATED CIRCUIT

勝特力材料 886-3-5753170
勝特力电子(上海) 86-21-54151736
勝特力电子(深圳) 86-755-83298787
[Http://www.100y.com.tw](http://www.100y.com.tw)

UTC assumes no responsibility for equipment failures that result from using products at values that exceed, even momentarily, rated values (such as maximum ratings, operating condition ranges, or other parameters) listed in products specifications of any and all UTC products described or contained herein. UTC products are not designed for use in life support appliances, devices or systems where malfunction of these products can be reasonably expected to result in personal injury. Reproduction in whole or in part is prohibited without the prior written consent of the copyright owner. The information presented in this document does not form part of any quotation or contract, is believed to be accurate and reliable and may be changed without notice.