

### Features and Benefits

- Built-in Reverse Voltage Protection
- Built-in RFI Filter
- Power Efficient CMOS and Power MOSFET Drivers allow 400mA without overheating
- Built-in Zener Diodes Protect Outputs
- Eliminate all Fan Components
- Eliminate PC Board
- 5V and 12V Operation
- High Sensitivity for switching symmetry
- Locked Rotor Shutdown

### Applications

- Fan sizes up to 90mm
- Current range up to 400mA

勝特力材料 886-3-5753170  
 勝特力电子(上海) 86-21-54151736  
 勝特力电子(深圳) 86-755-83298787  
[Http://www.100y.com.tw](http://www.100y.com.tw)

### Ordering Information

Part No.	Temperature Suffix	Package Code
US79	K (-40°C to 125°C)	UA (TO-92 flat)

## 1. Functional Diagram

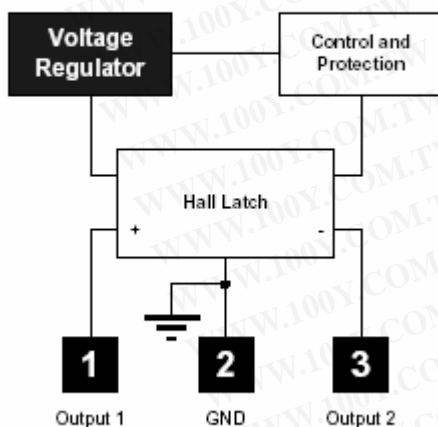

## 2. Description

The US79KUA is the most advanced Smart Fan Control Hall IC. It is designed for 5V and 12V cooling commutation. The chip contains many features to allow survival in a harsh environment. The IC was designed to eliminate all discrete components such as capacitors, resistors, transistors, diodes, PC board and associated labor, replacing US\$0.25 to US\$0.35 in direct cost.

The K rating guarantees proper operation up to an ambient temperature of 125°C. Hall IC circuitry and power FET output provide a low power dissipation cool chip.

Locked Rotor conditions are detected by the IC when there is no motion for one second and will shut off the motor drive for five seconds. Then, the IC will turn on the drive current for one second. This sequence continues indefinitely until the locked rotor condition is fixed. This feature prevents overheating.

## TABLE OF CONTENTS

FEATURES AND BENEFITS .....	1
APPLICATIONS.....	1
ORDERING INFORMATION.....	1
1. FUNCTIONAL DIAGRAM.....	1
2. DESCRIPTION.....	1
3. GLOSSARY OF TERMS .....	3
4. ABSOLUTE MAXIMUM RATINGS .....	3
5. US79 ELECTRICAL SPECIFICATIONS.....	3
6. US79 MAGNETIC SPECIFICATIONS.....	3
7. UNIQUE FEATURES.....	4
8. PERFORMANCE GRAPHS.....	4
9. APPLICATION INFORMATION .....	6
10. RELIABILITY INFORMATION.....	7
11. ESD PRECAUTIONS.....	7
12. PACKAGE INFORMATION.....	8
13. DISCLAIMER.....	9

勝特力材料 886-3-5753170  
勝特力电子(上海) 86-21-54151736  
勝特力电子(深圳) 86-755-83298787  
[Http://www.100y.com.tw](http://www.100y.com.tw)

### 3. Glossary of Terms

MilliTesla (mT), Gauss: Units of magnetic flux density; 1 milliTesla = 10 Gauss.

Two-Coil Fan: a fan with two coil windings, current alternates from 1 coil to the other depending on the polarity of the magnetic field.

Two-wire Fan: A fan that has only two connections for the power supply plus and minus.

Locked rotor: The condition of a fan that has stopped spinning due to mechanical blockage .

### 4. Absolute Maximum Ratings

Supply Voltage, $V_{DD}$	(-0.3 to 18)V
Output Current (Fault), $I_{OUT}$	500mA
Operating Temperature Range, $T_A$	-40 to 125°C
Storage Temperature Range, $T_S$	-55 to 165°C
Maximun Junction Temp, $T_J$	150°C

勝特力材料 886-3-5753170  
 勝特力电子(上海) 86-21-54151736  
 勝特力电子(深圳) 86-755-83298787  
[Http://www.100y.com.tw](http://www.100y.com.tw)

Exceeding the absolute maximum ratings may cause permanent damage. Exposure to absolute-maximum-rated conditions for extended periods may affect device reliability.

### 5. US79 Electrical Specifications

DC operating parameters:  $T_A = 25^\circ\text{C}$ ,  $V_{DD} = 12\text{V}$  unless otherwise specified

Parameter	Symbol	Test Conditions	Min	Typ	Max	Units
Supply Voltage	$V_{DD}$	Operating	3.5	-	18	V
Supply Current	$I_{DD}$	Operating		2.0	4	mA
Output Saturation voltage	$V_{DSS}$	$I_{OUT} = 150\text{mA}$		300	600	mV
Output Saturation voltage	$V_{DSS}$	$I_{OUT} = 350\text{mA}$		650	1100	mV
Thermal resistance	$R_{th}$	Operating		190		$^\circ\text{C/W}$
Locked-Rotor Period	$t_{on}$			0.8		S
Locked-Rotor period	$t_{off}$			5		S

### 6. US79 Magnetic Specifications

DC operating parameters:  $T_A = 25^\circ\text{C}$ ,  $V_{DD} = 12\text{V}$  unless otherwise specified.

Parameter	Symbol	Test Conditions	Min	Typ	Max	Units
Operate Point	$B_{OP}$	Operating		2.5	6.0	mT
Release Point	$B_{RP}$	Operating	-6.0	-2.5		mT
Hysteresis	$B_{HYS}$	Operating	2.0	5.0	-	mT

### 7. Unique Features

Reverse voltage protection eliminates the need for a diode. Reverse current flows through the coils and the chip. Power dissipation is  $(2 * I_{start}/I_{start} * 0.7V)$ .  
 Table 1 presents max temperature for each current.

I <sub>stall</sub> / I <sub>start</sub>	T <sub>A</sub> Maximum Rev V Test
100mA	125°C
200mA	100°C
300mA	70°C
400mA	40°C

Reverse Voltage protection is provided by the motor windings.  
 The 35V Zener diodes clamp the output drivers for overstress protection.

勝特力材料 886-3-5753170  
 勝特力电子(上海) 86-21-54151736  
 勝特力电子(深圳) 86-755-83298787  
[Http://www.100y.com.tw](http://www.100y.com.tw)

### 8. Performance Graphs

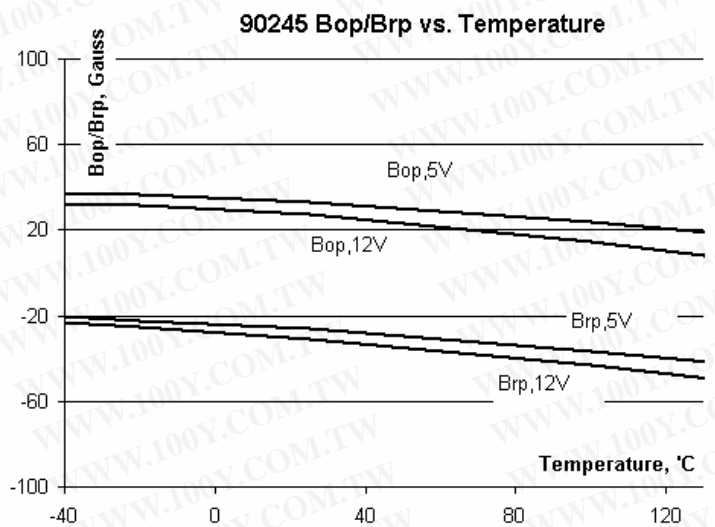
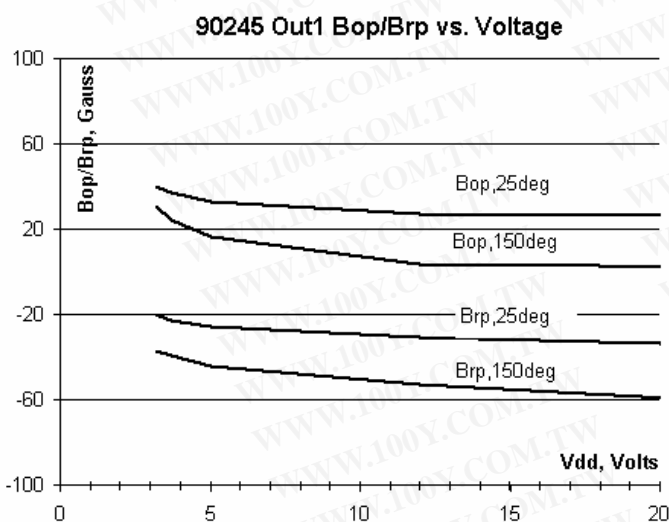

90245 Hysteresis Vs. Temperature

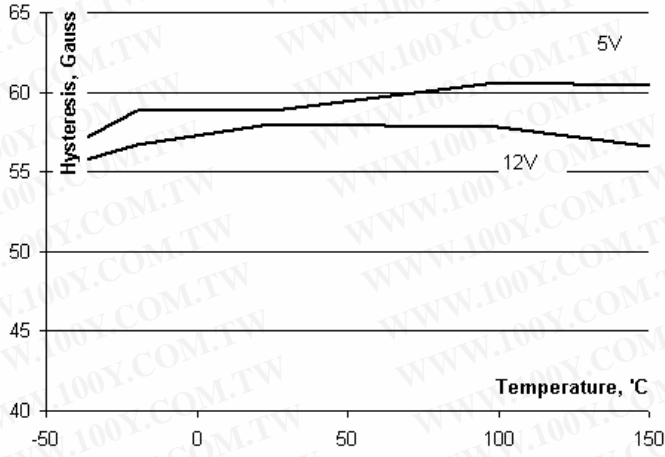

90245 Hysteresis vs. Voltage

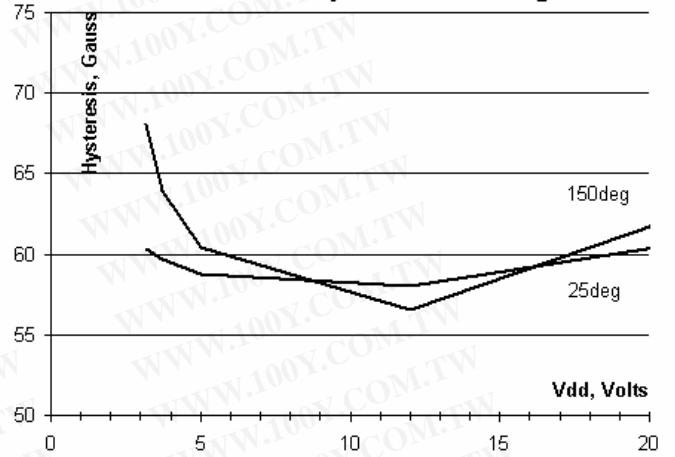

90245 Rdson vs. Temperature

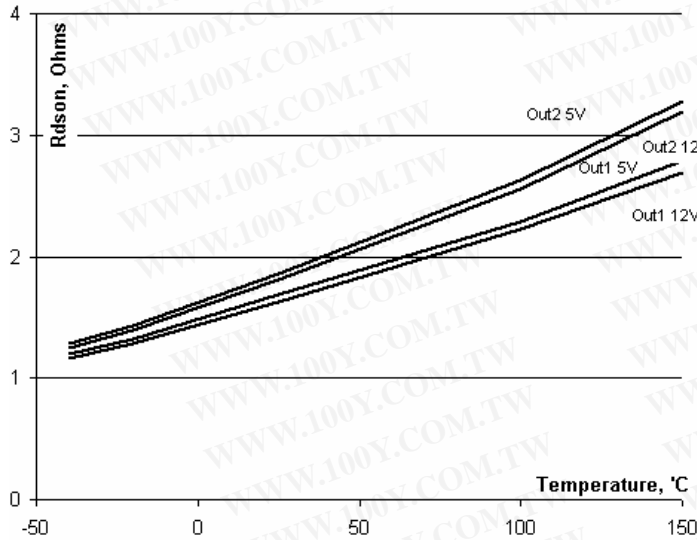

90245 Rdson vs. Voltage

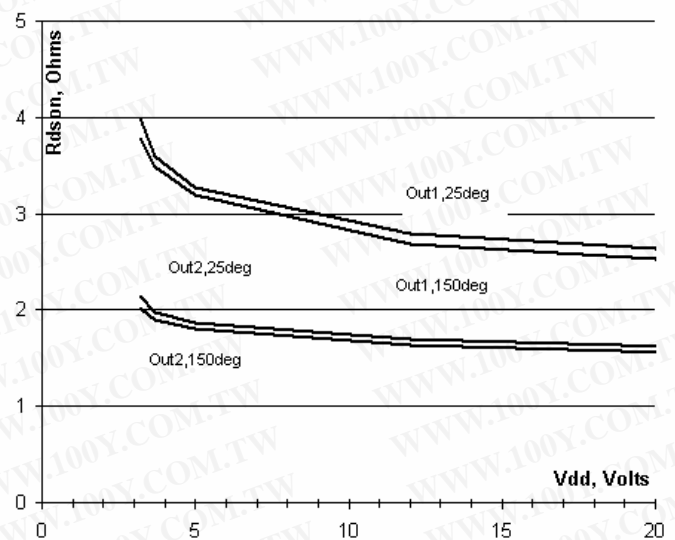

勝特力材料 886-3-5753170  
 勝特力电子(上海) 86-21-54151736  
 勝特力电子(深圳) 86-755-83298787  
[Http://www.100y.com.tw](http://www.100y.com.tw)

**9. Applications Information**

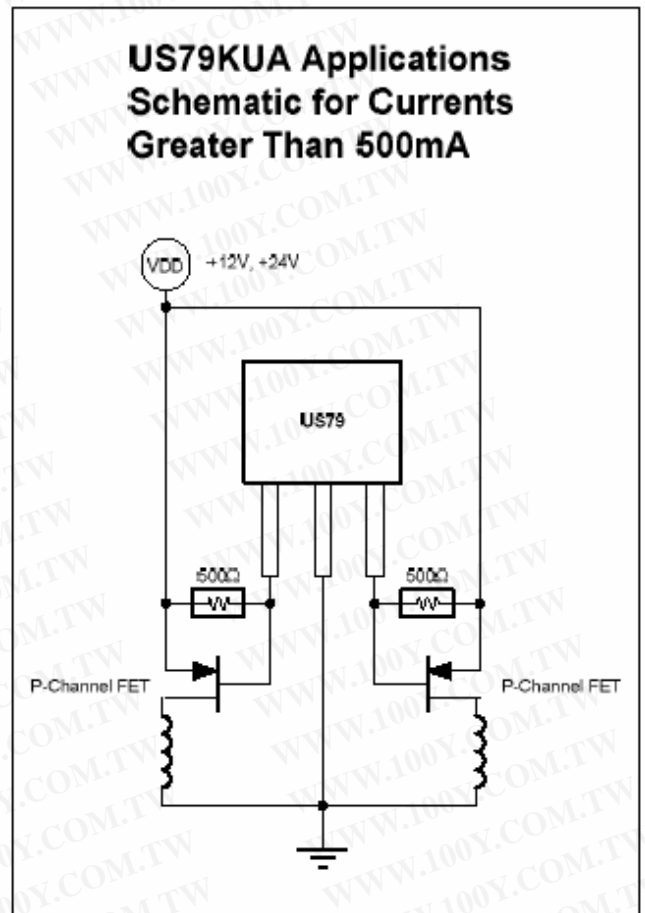
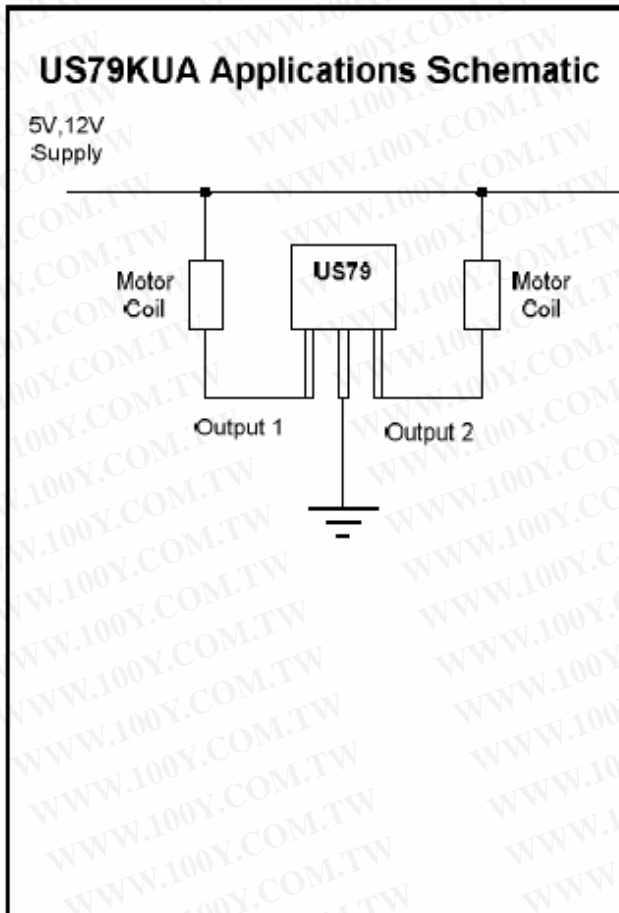

勝特力材料 886-3-5753170  
 勝特力电子(上海) 86-21-54151736  
 勝特力电子(深圳) 86-755-83298787  
[Http://www.100y.com.tw](http://www.100y.com.tw)

### 10. Reliability Information

This Melexis device is classified and qualified regarding soldering technology, solderability and moisture sensitivity level, as defined in this specification, according to following test methods:

- IPC/JEDEC J-STD-020  
Moisture/Reflow Sensitivity Classification For Nonhermetic Solid State Surface Mount Devices (classification reflow profiles according to table 5-2)
- EIA/JEDEC JESD22-A113  
Preconditioning of Nonhermetic Surface Mount Devices Prior to Reliability Testing (reflow profiles according to table 2)
- CECC00802  
Standard Method For The Specification of Surface Mounting Components (SMDs) of Assessed Quality
- EIA/JEDEC JESD22-B106  
Resistance to soldering temperature for through-hole mounted devices
- EN60749-15  
Resistance to soldering temperature for through-hole mounted devices
- MIL 883 Method 2003 / EIA/JEDEC JESD22-B102  
Solderability

For all soldering technologies deviating from above mentioned standard conditions (regarding peak temperature, temperature gradient, temperature profile etc) additional classification and qualification tests have to be agreed upon with Melexis.

The application of Wave Soldering for SMD's is allowed only after consulting Melexis regarding assurance of adhesive strength between device and board.

Based on Melexis commitment to environmental responsibility, European legislation (Directive on the Restriction of the Use of Certain Hazardous substances, RoHS) and customer requests, Melexis has installed a Roadmap to qualify their package families for lead free processes also. Various lead free generic qualifications are running, current results on request.

For more information on manufacturability/solderability see quality page at our website:

<http://www.melexis.com/html/pdf/MLXleadfree-statement.pdf>

### 11. ESD Precautions

Electronic semiconductor products are sensitive to Electro Static Discharge (ESD).

Always observe Electro Static Discharge control procedures whenever handling semiconductor products.

勝特力材料 886-3-5753170  
勝特力电子(上海) 86-21-54151736  
勝特力电子(深圳) 86-755-83298787  
[Http://www.100y.com.tw](http://www.100y.com.tw)

### 12. Package Information

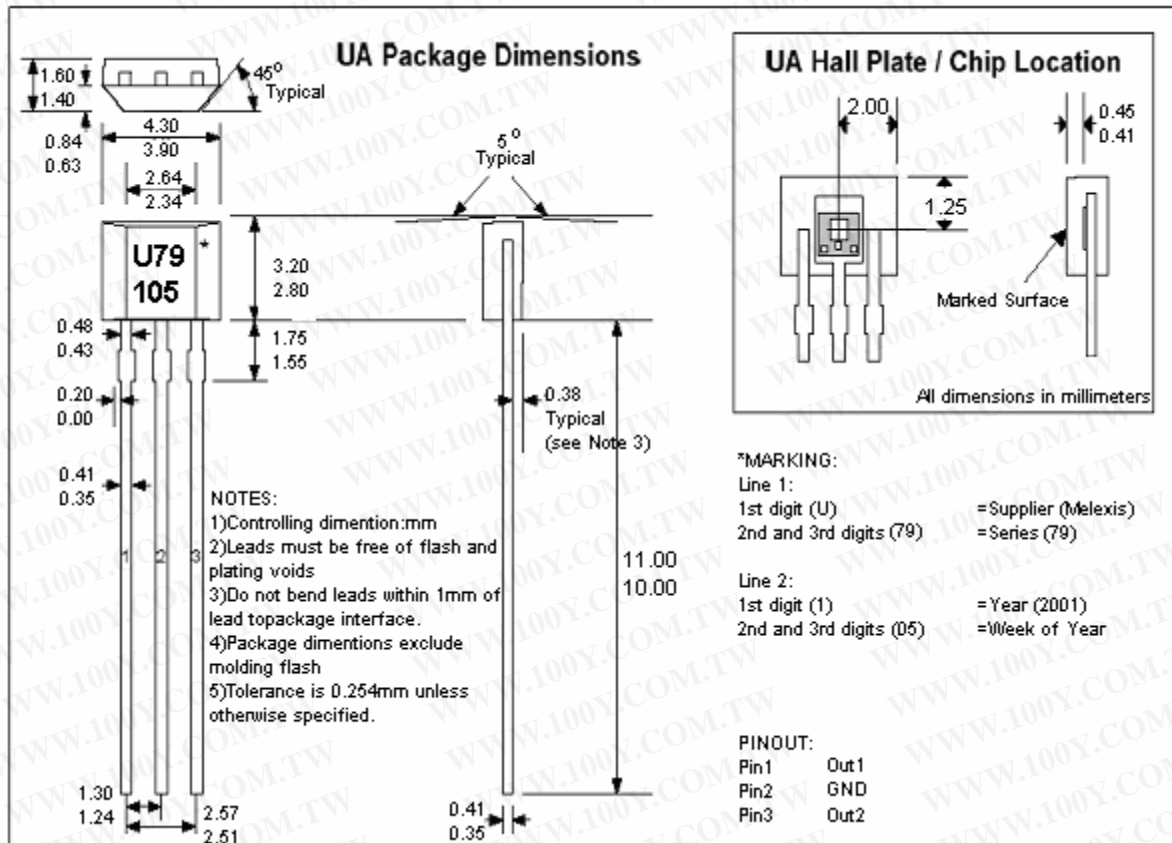

勝特力材料 886-3-5753170  
 勝特力电子(上海) 86-21-54151736  
 勝特力电子(深圳) 86-755-83298787  
[Http://www.100y.com.tw](http://www.100y.com.tw)

### 13. Disclaimer

Devices sold by Melexis are covered by the warranty and patent indemnification provisions appearing in its Term of Sale. Melexis makes no warranty, express, statutory, implied, or by description regarding the information set forth herein or regarding the freedom of the described devices from patent infringement. Melexis reserves the right to change specifications and prices at any time and without notice. Therefore, prior to designing this product into a system, it is necessary to check with Melexis for current information. This product is intended for use in normal commercial applications. Applications requiring extended temperature range, unusual environmental requirements, or high reliability applications, such as military, medical life-support or life-sustaining equipment are specifically not recommended without additional processing by Melexis for each application.

The information furnished by Melexis is believed to be correct and accurate. However, Melexis shall not be liable to recipient or any third party for any damages, including but not limited to personal injury, property damage, loss of profits, loss of use, interrupt of business or indirect, special incidental or consequential damages, of any kind, in connection with or arising out of the furnishing, performance or use of the technical data herein. No obligation or liability to recipient or any third party shall arise or flow out of Melexis' rendering of technical or other services.

© 2002 Melexis NV. All rights reserved.

勝特力材料 886-3-5753170  
勝特力电子(上海) 86-21-54151736  
勝特力电子(深圳) 86-755-83298787  
[Http://www.100y.com.tw](http://www.100y.com.tw)

For the latest version of this document, go to our website at:

**[www.melexis.com](http://www.melexis.com)**

Or for additional information contact Melexis Direct:

Europe and Japan:

Phone: +32 13 67 04 95  
E-mail: [sales\\_europe@melexis.com](mailto:sales_europe@melexis.com)

All other locations:

Phone: +1 603 223 2362  
E-mail: [sales\\_usa@melexis.com](mailto:sales_usa@melexis.com)

ISO/TS 16949 and ISO14001 Certified