

ULN2001A, ULN2002A, ULN2003A, ULN2004A DARLINGTON TRANSISTOR ARRAYS

SLRS027 – DECEMBER 1976 – REVISED APRIL 1993

HIGH-VOLTAGE HIGH-CURRENT DARLINGTON TRANSISTOR ARRAYS

- 500-mA Rated Collector Current (Single Output)
- High-Voltage Outputs . . . 50 V
- Output Clamp Diodes
- Inputs Compatible With Various Types of Logic
- Relay Driver Applications
- Designed to Be Interchangeable With Sprague ULN2001A Series

D OR N PACKAGE
(TOP VIEW)

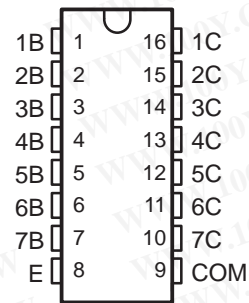

description

The ULN2001A, ULN2002A, ULN2003A, and ULN2004A are monolithic high-voltage, high-current Darlington transistor arrays. Each consists of seven npn Darlington pairs that feature high-voltage outputs with common-cathode clamp diodes for switching inductive loads. The collector-current rating of a single Darlington pair is 500 mA. The Darlington pairs may be paralleled for higher current capability. Applications include relay drivers, hammer drivers, lamp drivers, display drivers (LED and gas discharge), line drivers, and logic buffers. For 100-V (otherwise interchangeable) versions, see the SN75465 through SN75469.

The ULN2001A is a general-purpose array and can be used with TTL and CMOS technologies. The ULN2002A is specifically designed for use with 14- to 25-V PMOS devices. Each input of this device has a zener diode and resistor in series to control the input current to a safe limit. The ULN2003A has a 2.7-k Ω series base resistor for each Darlington pair for operation directly with TTL or 5-V CMOS devices. The ULN2004A has a 10.5-k Ω series base resistor to allow its operation directly from CMOS devices that use supply voltages of 6 to 15 V. The required input current of the ULN2004A is below that of the ULN2003A, and the required voltage is less than that required by the ULN2002A.

logic symbol†

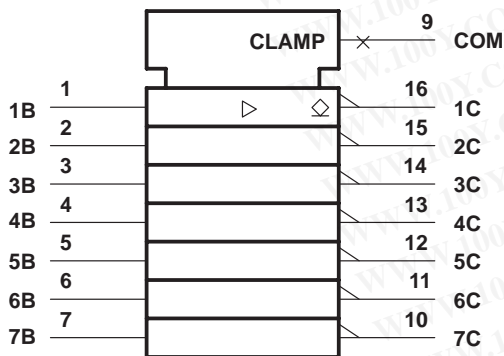

† This symbol is in accordance with ANSI/IEEE Std 91-1984 and IEC Publication 617-12.

logic diagram

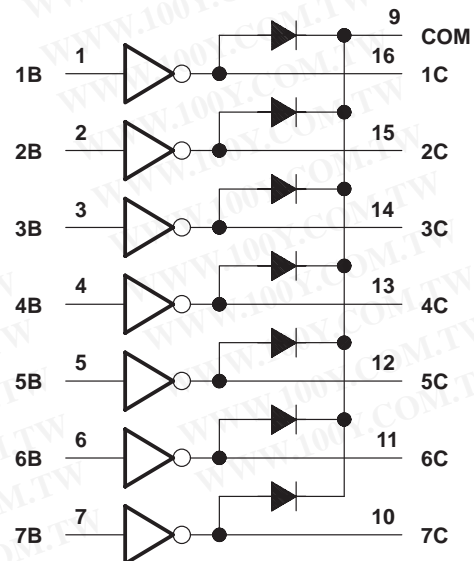

勝特力材料 886-3-5753170
 勝特力电子(上海) 86-21-54151736
 勝特力电子(深圳) 86-755-83298787
[Http://www.100y.com.tw](http://www.100y.com.tw)

ULN2001A, ULN2002A, ULN2003A, ULN2004A DARLINGTON TRANSISTOR ARRAYS

SLRS027 – DECEMBER 1976 – REVISED APRIL 1993

勝特力材料 886-3-5753170
 勝特力电子(上海) 86-21-54151736
 勝特力电子(深圳) 86-755-83298787
[Http://www.100y.com.tw](http://www.100y.com.tw)

schematics (each Darlington pair)

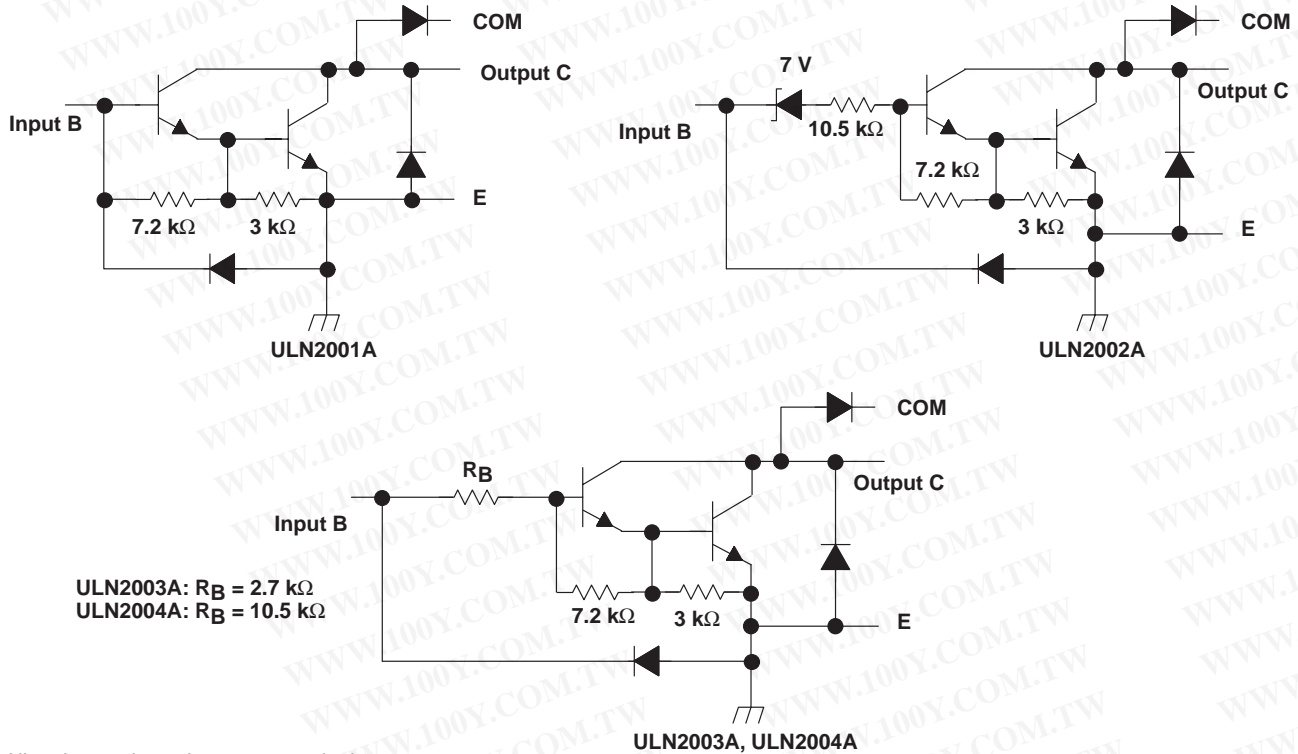

All resistor values shown are nominal.

absolute maximum ratings at 25°C free-air temperature (unless otherwise noted)

Collector-emitter voltage	50 V
Input voltage, V_I (see Note 1)	30 V
Peak collector current (see Figures 14 and 15)	500 mA
Output clamp current, I_{OK}	500 mA
Total emitter-terminal current	-2.5 A
Continuous total power dissipation	See Dissipation Rating Table
Operating free-air temperature range, T_A	-20°C to 85°C
Storage temperature range, T_{stg}	-65°C to 150°C
Lead temperature 1,6 mm (1/16 inch) from case for 10 seconds	260°C

NOTE 1: All voltage values are with respect to the emitter/substrate terminal E, unless otherwise noted.

DISSIPATION RATING TABLE

PACKAGE	$T_A = 25^\circ\text{C}$ POWER RATING	DERATING FACTOR ABOVE $T_A = 25^\circ\text{C}$	$T_A = 85^\circ\text{C}$ POWER RATING
D	950 mW	7.6 mW/°C	494 mW
N	1150 mW	9.2 mW/°C	598 mW



POST OFFICE BOX 655303 • DALLAS, TEXAS 75265

electrical characteristics, $T_A = 25^\circ\text{C}$ (unless otherwise noted)

PARAMETER	TEST FIGURE	TEST CONDITIONS	ULN2001A			ULN2002A			UNIT	
			MIN	TYP	MAX	MIN	TYP	MAX		
$V_{I(on)}$	On-state input voltage	6	$V_{CE} = 2\text{ V}, I_C = 300\text{ mA}$					13	V	
$V_{CE(sat)}$	Collector-emitter saturation voltage	5	$I_I = 250\ \mu\text{A}, I_C = 100\text{ mA}$		0.9	1.1	0.9	1.1	V	
			$I_I = 350\ \mu\text{A}, I_C = 200\text{ mA}$		1	1.3	1	1.3		
			$I_I = 500\ \mu\text{A}, I_C = 350\text{ mA}$		1.2	1.6	1.2	1.6		
V_F	Clamp forward voltage	8	$I_F = 350\text{ mA}$		1.7	2	1.7	2	V	
I_{CEX}	Collector cutoff current	1	$V_{CE} = 50\text{ V}, I_I = 0$		50			50	μA	
		2	$V_{CE} = 50\text{ V}, T_A = 70^\circ\text{C}$	$I_I = 0$	100			100		
				$V_I = 6\text{ V}$				500		
$I_{I(off)}$	Off-state input current	3	$V_{CE} = 50\text{ V}, I_C = 500\ \mu\text{A}, T_A = 70^\circ\text{C}$		50	65	50	65	μA	
I_I	Input current	4	$V_I = 17\text{ V}$					0.82	1.25	mA
I_R	Clamp reverse current	7	$V_R = 50\text{ V}, T_A = 70^\circ\text{C}$		100			100		μA
			$V_R = 50\text{ V}$		50			50		
h_{FE}	Static forward current transfer ratio	5	$V_{CE} = 2\text{ V}, I_C = 350\text{ mA}$		1000					
C_i	Input capacitance		$V_I = 0, f = 1\text{ MHz}$		15	25	15	25	pF	

electrical characteristics, $T_A = 25^\circ\text{C}$ (unless otherwise noted)

PARAMETER	TEST FIGURE	TEST CONDITIONS	ULN2003A			ULN2004A			UNIT	
			MIN	TYP	MAX	MIN	TYP	MAX		
$V_{I(on)}$	On-state input voltage	6	$V_{CE} = 2\text{ V}$	$I_C = 125\text{ mA}$					5	V
				$I_C = 200\text{ mA}$					6	
				$I_C = 250\text{ mA}$					7	
				$I_C = 275\text{ mA}$					7	
				$I_C = 300\text{ mA}$					8	
				$I_C = 350\text{ mA}$					8	
$V_{CE(sat)}$	Collector-emitter saturation voltage	5	$I_I = 250\ \mu\text{A}, I_C = 100\text{ mA}$		0.9	1.1	0.9	1.1	V	
			$I_I = 350\ \mu\text{A}, I_C = 200\text{ mA}$		1	1.3	1	1.3		
			$I_I = 500\ \mu\text{A}, I_C = 350\text{ mA}$		1.2	1.6	1.2	1.6		
I_{CEX}	Collector cutoff current	1	$V_{CE} = 50\text{ V}, I_I = 0$		50			50	μA	
		2	$V_{CE} = 50\text{ V}, T_A = 70^\circ\text{C}$	$I_I = 0$	100			100		
				$V_I = 1\text{ V}$				500		
V_F	Clamp forward voltage	8	$I_F = 350\text{ mA}$		1.7	2	1.7	2	V	
$I_{I(off)}$	Off-state input current	3	$V_{CE} = 50\text{ V}, I_C = 500\ \mu\text{A}, T_A = 70^\circ\text{C}$		50	65	50	65	μA	
I_I	Input current	4	$V_I = 3.85\text{ V}$		0.93	1.35			mA	
			$V_I = 5\text{ V}$					0.35		0.5
			$V_I = 12\text{ V}$					1		1.45
I_R	Clamp reverse current	7	$V_R = 50\text{ V}$		50			50	μA	
			$V_R = 50\text{ V}, T_A = 70^\circ\text{C}$		100			100		
C_i	Input capacitance		$V_I = 0, f = 1\text{ MHz}$		15	25	15	25	pF	

ULN2001A, ULN2002A, ULN2003A, ULN2004A DARLINGTON TRANSISTOR ARRAYS

勝特力材料 886-3-5753170
 勝特力电子(上海) 86-21-54151736
 勝特力电子(深圳) 86-755-83298787
[Http://www.100y.com.tw](http://www.100y.com.tw)

SLRS027 – DECEMBER 1976 – REVISED APRIL 1993

switching characteristics, $T_A = 25^\circ\text{C}$

PARAMETER	TEST CONDITIONS	MIN	TYP	MAX	UNIT
t_{PLH} Propagation delay time, low-to-high-level output	See Figure 9		0.25	1	μs
t_{PHL} Propagation delay time, high-to-low-level output			0.25	1	μs
V_{OH} High-level output voltage after switching	$V_S = 50\text{ V}$, See Figure 10	$V_S - 20$			mV

PARAMETER MEASUREMENT INFORMATION

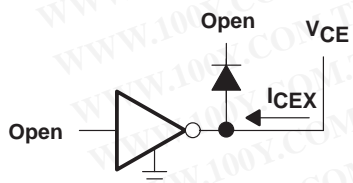

Figure 1. I_{CEX} Test Circuit

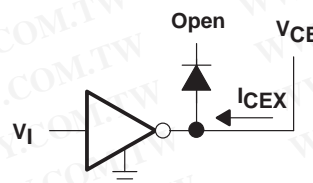

Figure 2. I_{CEX} Test Circuit

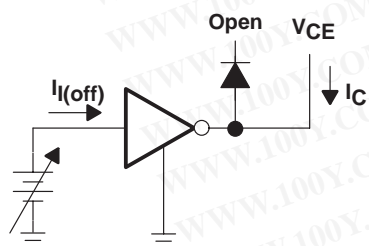

Figure 3. $I_{1(off)}$ Test Circuit

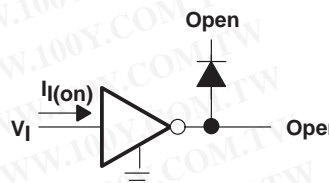
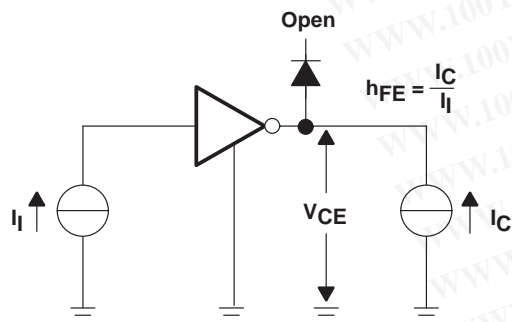

Figure 4. I_1 Test Circuit



NOTE: I_1 is fixed for measuring $V_{CE(sat)}$, variable for measuring h_{FE} .

Figure 5. h_{FE} , $V_{CE(sat)}$ Test Circuit

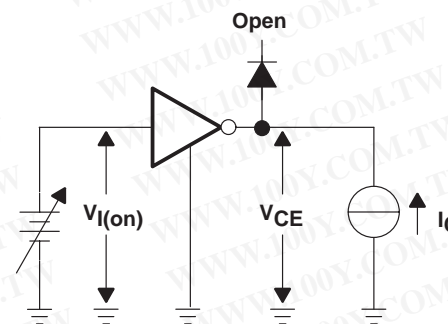

Figure 6. $V_{I(on)}$ Test Circuit

PARAMETER MEASUREMENT INFORMATION

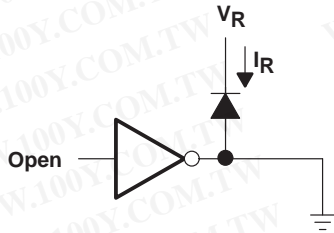

Figure 7. I_R Test Circuit

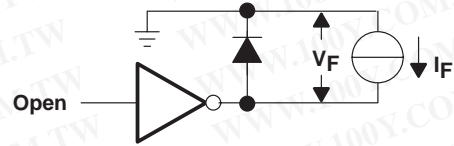

Figure 8. V_F Test Circuit

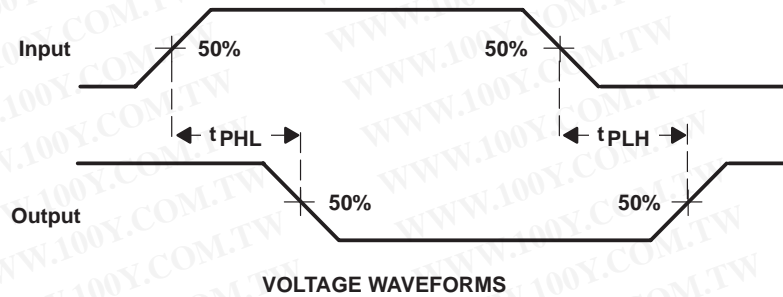
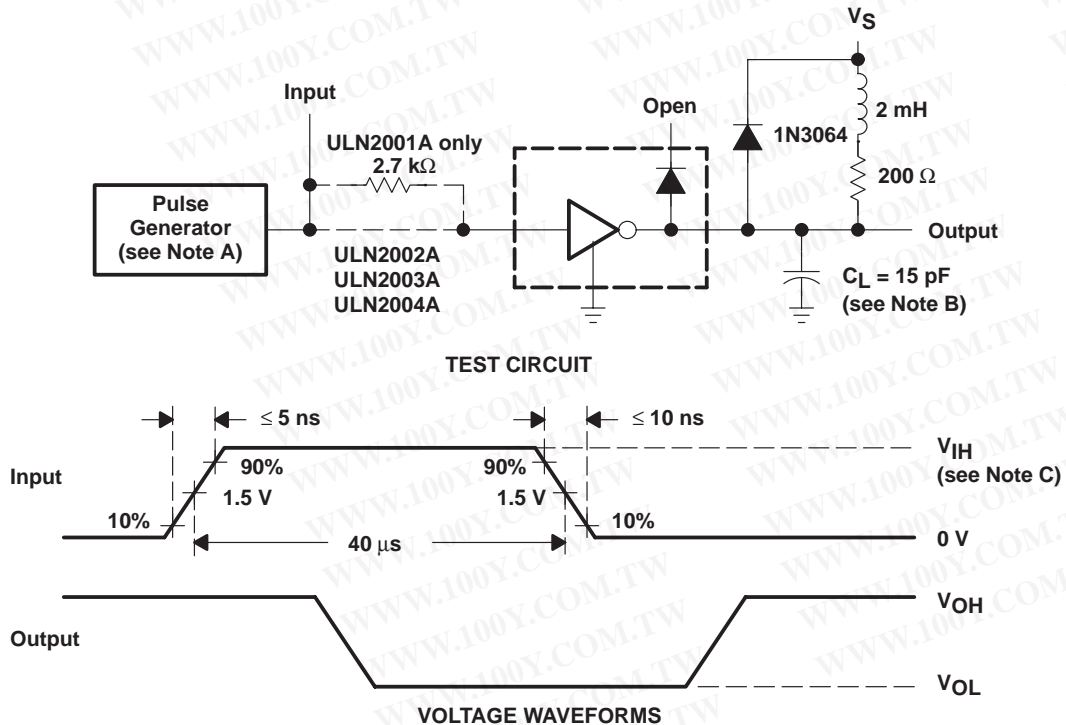

Figure 9. Propagation Delay Time Waveforms



- NOTES: A. The pulse generator has the following characteristics: PRR = 12.5 kHz, $Z_O = 50 \Omega$.
 B. C_L includes probe and jig capacitance.
 C. For testing the ULN2001A and ULN2003A, $V_{IH} = 3 V$; for the ULN2002A, $V_{IH} = 13 V$; for the ULN2004A, $V_{IH} = 8 V$.

Figure 10. Latch-Up Test Circuit and Voltage Waveforms

TYPICAL CHARACTERISTICS

COLLECTOR-EMITTER SATURATION VOLTAGE vs COLLECTOR CURRENT (ONE DARLINGTON)

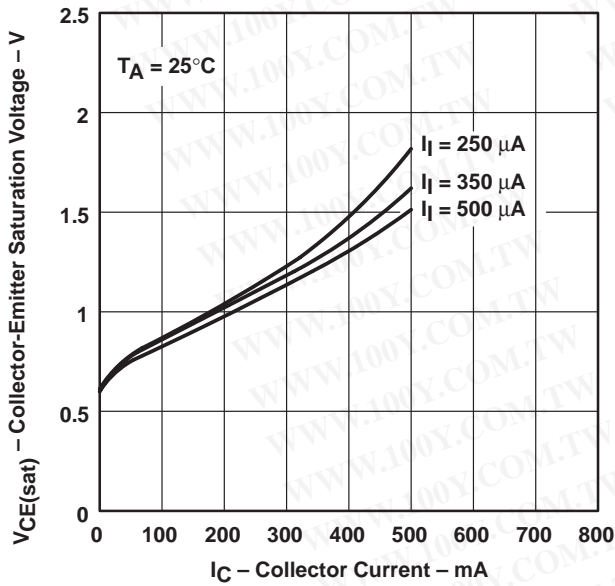

Figure 11

COLLECTOR-EMITTER SATURATION VOLTAGE vs TOTAL COLLECTOR CURRENT (TWO DARLINGTONS PARALLELED)

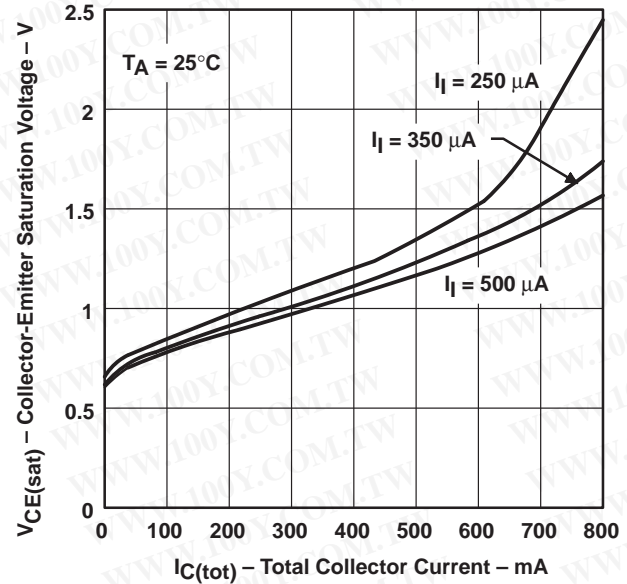

Figure 12

COLLECTOR CURRENT vs INPUT CURRENT

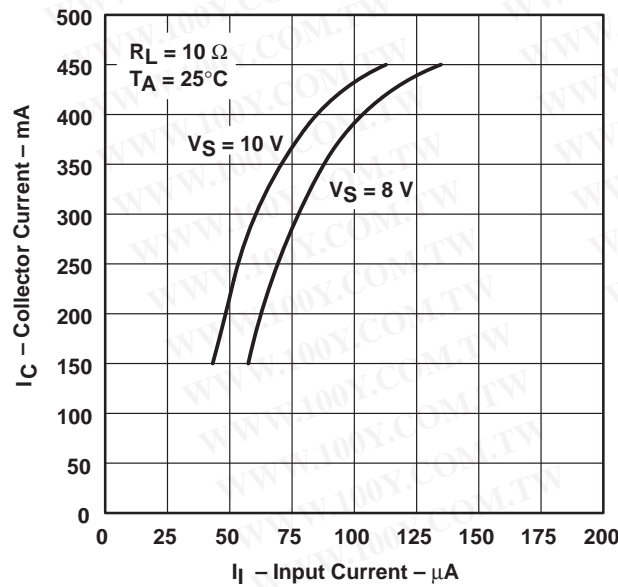
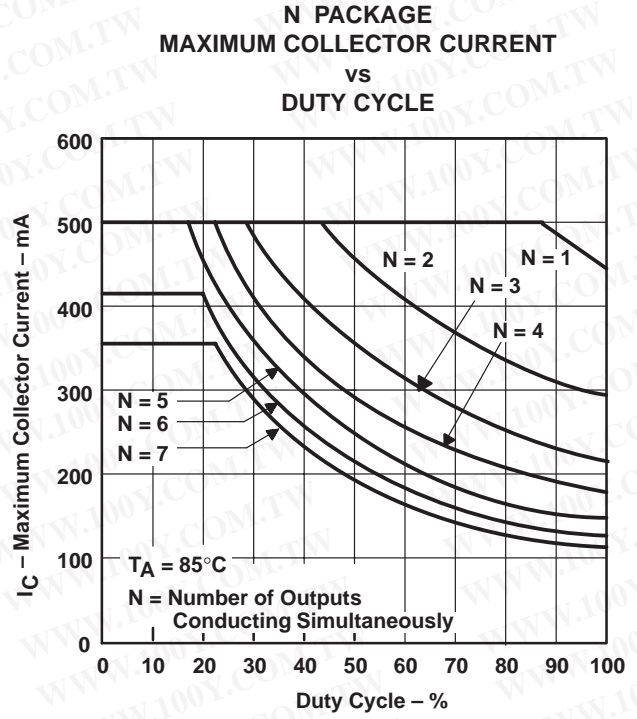
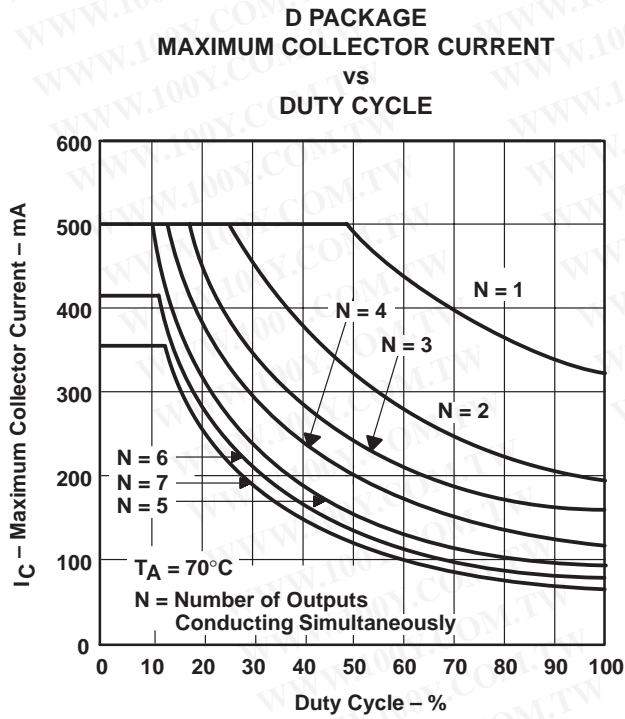

Figure 13

THERMAL INFORMATION



APPLICATION INFORMATION

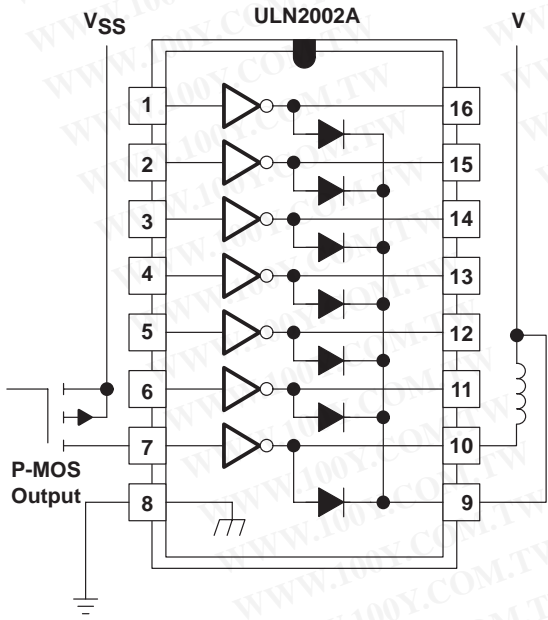

Figure 16. P-MOS to Load

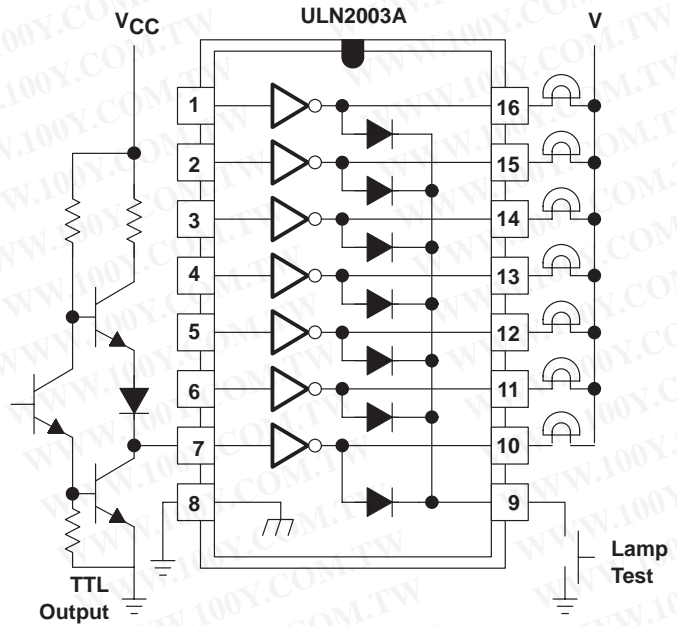

Figure 17. TTL to Load

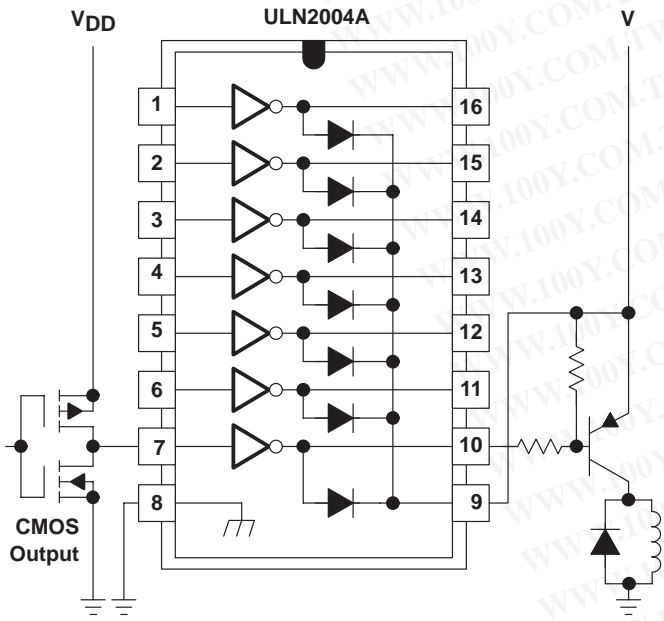

Figure 18. Buffer for Higher Current Loads

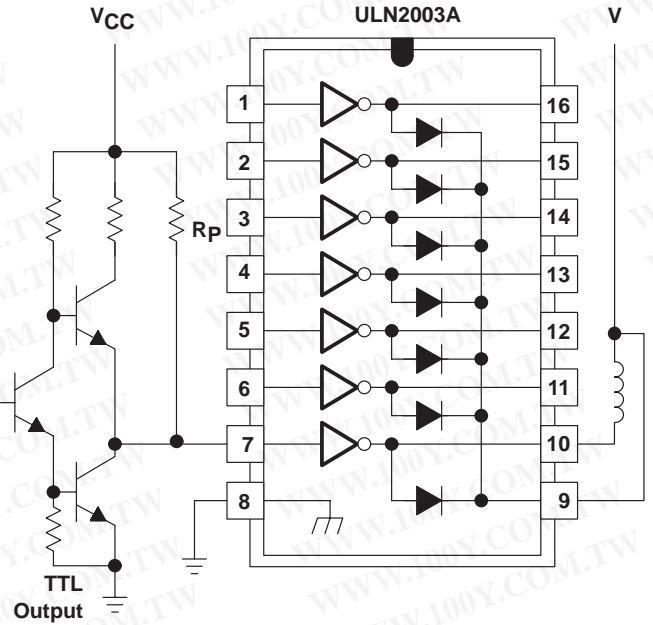

Figure 19. Use of Pullup Resistors to Increase Drive Current

勝特力材料 886-3-5753170
勝特力电子(上海) 86-21-54151736
勝特力电子(深圳) 86-755-83298787
[Http://www.100y.com.tw](http://www.100y.com.tw)

IMPORTANT NOTICE

Texas Instruments and its subsidiaries (TI) reserve the right to make changes to their products or to discontinue any product or service without notice, and advise customers to obtain the latest version of relevant information to verify, before placing orders, that information being relied on is current and complete. All products are sold subject to the terms and conditions of sale supplied at the time of order acknowledgement, including those pertaining to warranty, patent infringement, and limitation of liability.

TI warrants performance of its semiconductor products to the specifications applicable at the time of sale in accordance with TI's standard warranty. Testing and other quality control techniques are utilized to the extent TI deems necessary to support this warranty. Specific testing of all parameters of each device is not necessarily performed, except those mandated by government requirements.

CERTAIN APPLICATIONS USING SEMICONDUCTOR PRODUCTS MAY INVOLVE POTENTIAL RISKS OF DEATH, PERSONAL INJURY, OR SEVERE PROPERTY OR ENVIRONMENTAL DAMAGE ("CRITICAL APPLICATIONS"). TI SEMICONDUCTOR PRODUCTS ARE NOT DESIGNED, AUTHORIZED, OR WARRANTED TO BE SUITABLE FOR USE IN LIFE-SUPPORT DEVICES OR SYSTEMS OR OTHER CRITICAL APPLICATIONS. INCLUSION OF TI PRODUCTS IN SUCH APPLICATIONS IS UNDERSTOOD TO BE FULLY AT THE CUSTOMER'S RISK.

In order to minimize risks associated with the customer's applications, adequate design and operating safeguards must be provided by the customer to minimize inherent or procedural hazards.

TI assumes no liability for applications assistance or customer product design. TI does not warrant or represent that any license, either express or implied, is granted under any patent right, copyright, mask work right, or other intellectual property right of TI covering or relating to any combination, machine, or process in which such semiconductor products or services might be or are used. TI's publication of information regarding any third party's products or services does not constitute TI's approval, warranty or endorsement thereof.

Copyright © 1998, Texas Instruments Incorporated