

TOSHIBA BIPOLAR LINEAR INTEGRATED CIRCUIT SILICON MONOLITHIC

TA8435H

PWM CHOPPER TYPE BIPOLAR STEPPING MOTOR DRIVER.

The TA8435H is PWM chopper type sinusoidal micro step bipolar stepping motor driver.

Sinusoidal micro step operation is accomplished only a clock signal inputting by means of built-in hard ware.

FEATURES

- 1 chip bipolar sinusoidal micro step stepping motor driver.
- Output current up to 1.5 A (AVE.) and 2.5 A (PEAK).
- PWM chopper type.
- Structured by high voltage Bi-CMOS process technology.
- Forward and reverse rotation are available.
- 2, 1-2, W1-2, 2W1-2 phase 1 or 2 clock drives are selectable.
- Package : HZIP25-P
- Input Pull-up Resistor equipped with $\overline{\text{RESET}}$ Terminal: $R = 100 \text{ k}\Omega$ (Typ.)
- Output Monitor available with $\overline{\text{MO}}$ $I_{O(\overline{\text{MO}})} = \pm 2 \text{ mA}$ (MAX.)
- Reset and Enable are available with $\overline{\text{RESET}}$ and $\overline{\text{ENABLE}}$.

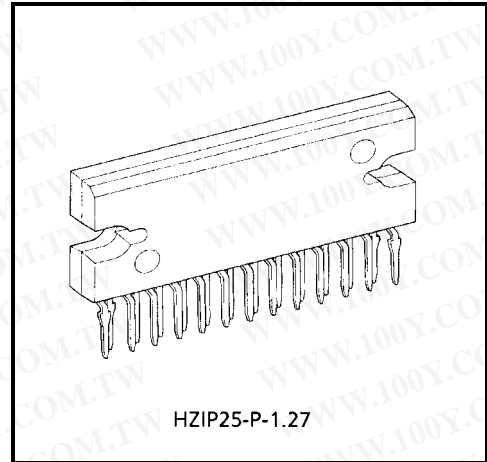

Weight: 9.86 g (Typ.)

勝特力材料 886-3-5753170
 勝特力电子(上海) 86-21-54151736
 勝特力电子(深圳) 86-755-83298787
[Http://www.100y.com.tw](http://www.100y.com.tw)

BLOCK DIAGRAM

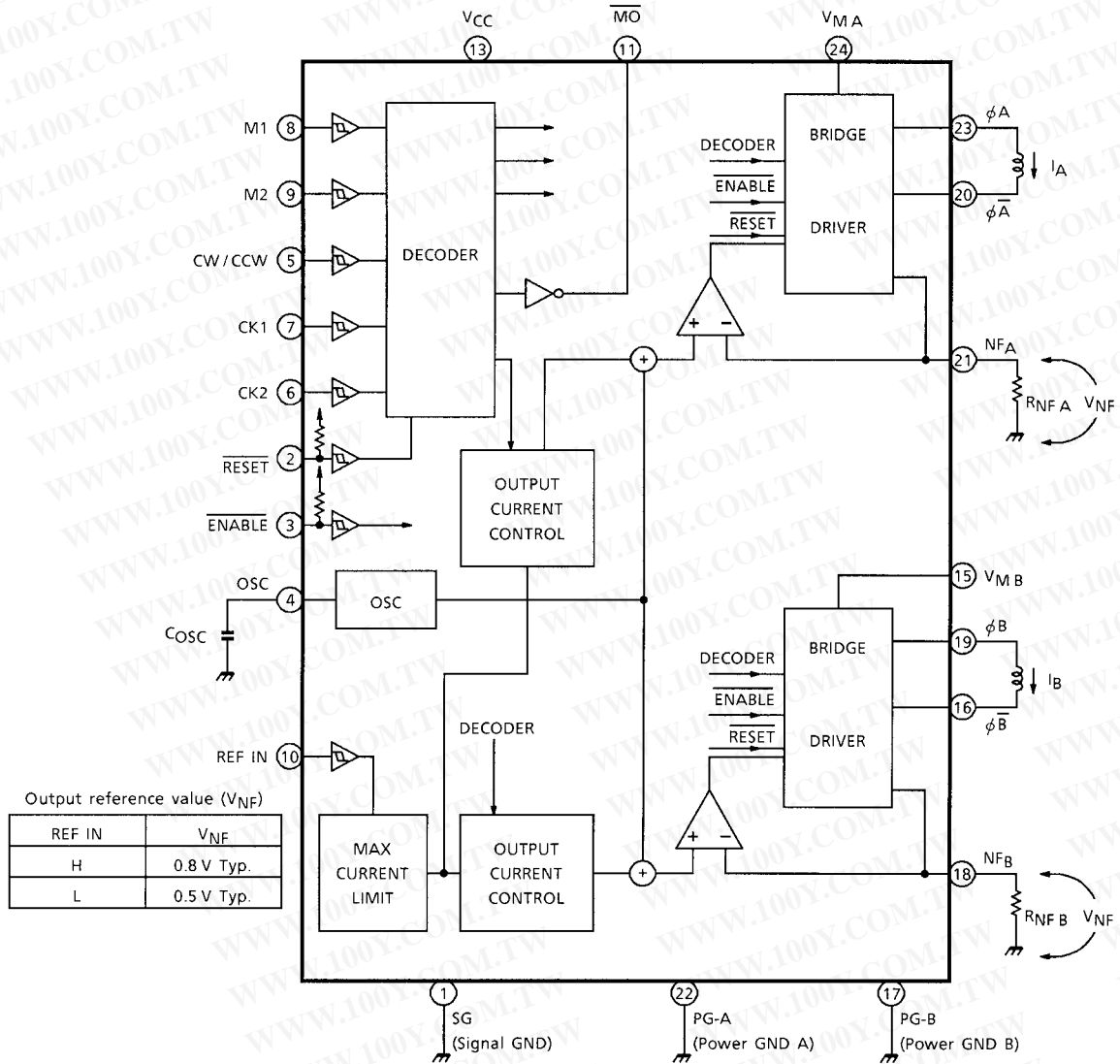

Pull-up resistance : 100 kΩ (Typ.)
 Pin 12、14、25 : Non connection

勝特力材料 886-3-5753170
 勝特力电子(上海) 86-21-54151736
 勝特力电子(深圳) 86-755-83298787
[Http://www.100y.com.tw](http://www.100y.com.tw)

PIN CONNECTION (Top view)

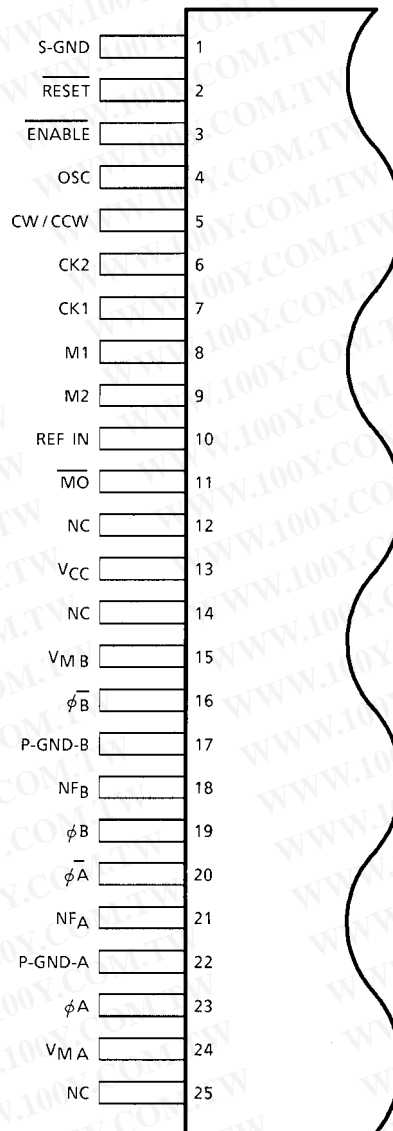

Note: NC : No connection

勝特力材料 886-3-5753170
勝特力电子(上海) 86-21-54151736
勝特力电子(深圳) 86-755-83298787
[Http://www.100y.com.tw](http://www.100y.com.tw)

PIN FUNCTION

PIN No	SYMBOL	FUNCTIONAL DESCRIPTION
1	SG	Signal GND.
2	$\overline{\text{RESET}}$	L : RESET.
3	$\overline{\text{ENABLE}}$	L : ENABLE, H: OFF.
4	OSC	Chopping oscillation is determined by the external capacitor.
5	CW / CCW	Forward / Reverse switching terminal.
6	CK2	Clock input terminal.
7	CK1	Clock input terminal.
8	M1	Excitation control input
9	M2	Excitation control input
10	REF IN	V_{NF} control input
11	$\overline{\text{MO}}$	Monitor output
12	NC	No connection.
13	V_{CC}	Voltage supply for logic.
14	NC	No connection.
15	V_{MB}	Output power supply terminal.
16	$\phi \overline{\text{B}}$	Output $\phi \overline{\text{B}}$
17	PG-B	Power GND.
18	NF_{B}	B-ch output current detection terminal.
19	ϕB	Output ϕB
20	$\phi \overline{\text{A}}$	Output $\phi \overline{\text{A}}$
21	NF_{A}	A-ch output current detection terminal.
22	PG-A	Power GND
23	ϕA	Output ϕA
24	V_{MA}	Output power supply terminal.
25	NC	No connection.

勝特力材料 886-3-5753170
 勝特力电子(上海) 86-21-54151736
 勝特力电子(深圳) 86-755-83298787
[Http://www.100y.com.tw](http://www.100y.com.tw)

OUTPUT CIRCUIT

勝特力材料 886-3-5753170
 胜特力电子(上海) 86-21-54151736
 胜特力电子(深圳) 86-755-83298787
[Http://www.100y.com.tw](http://www.100y.com.tw)

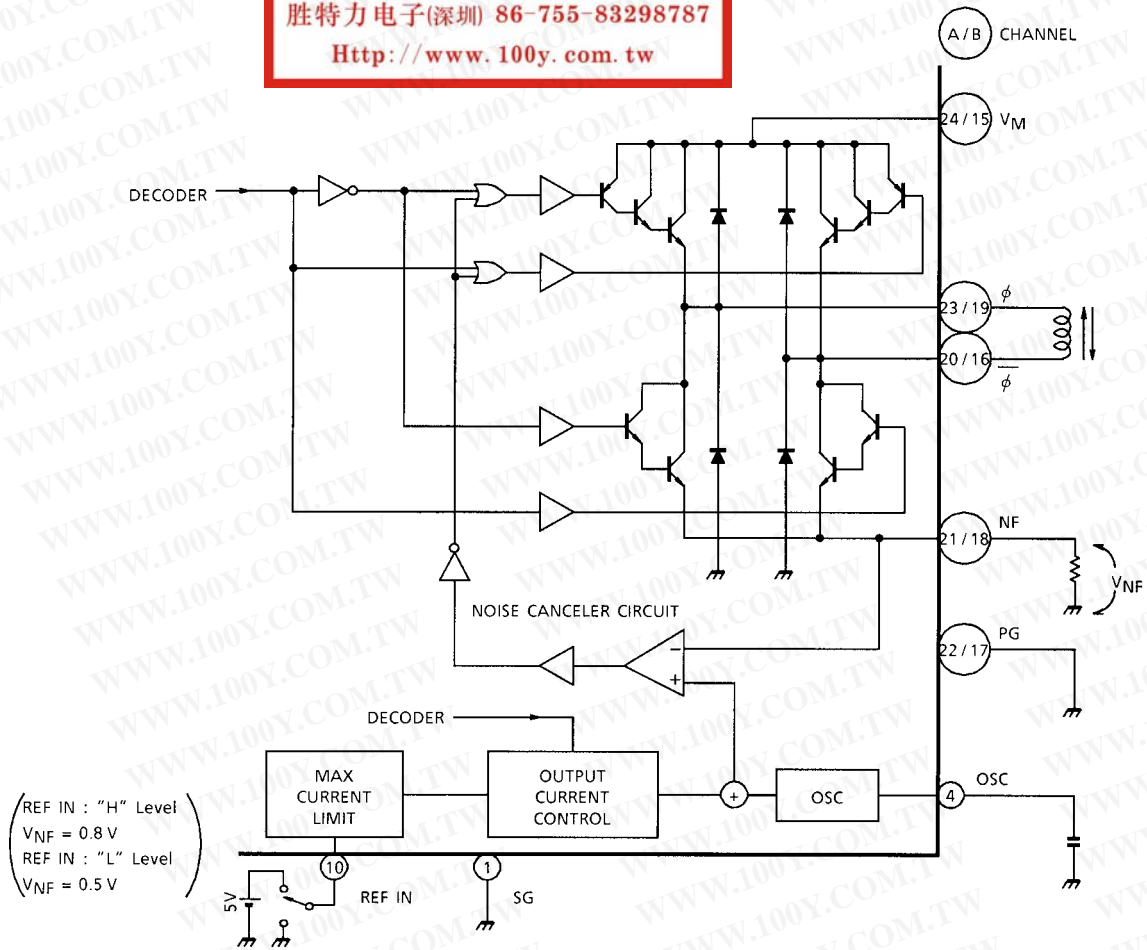

INPUT CIRCUIT

- CK1, CK2, CW / CCW, M1, M2, REF IN: Terminals
- \overline{RESET} , \overline{ENABLE} : Terminals
- OSC: Terminal

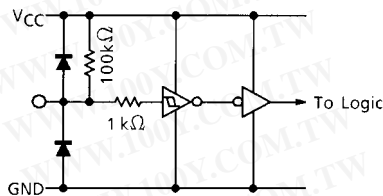
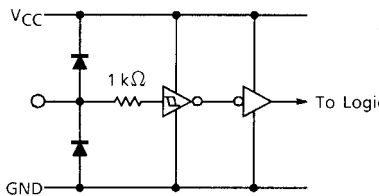

100 kΩ of Pull-up Resistor is equipped.

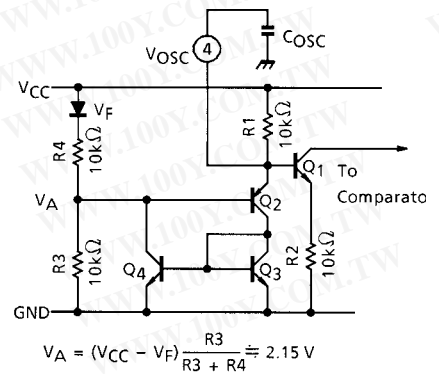

OSC FREQUENCY CALCULATION

Sawtooth OSC circuit consists of Q1 through Q4 and R1 through R4.

Q2 is turned "off" when VOSC is less than the voltage of 2.5 V + VBE Q2 approximately equal to 2.85 V.

VOSC is increased by COSC charging through R1.

Q3 and Q4 are turned "on" when VOSC becomes 2.85 V (Higher level.)

Lower level of V (4) pin is equal to VBE Q2 + VSAT Q4 approximately equal to 1.4 V.

VOSC is calculated by following equation.

$$V_{OSC} = 5 \cdot \left[1 - \exp\left(-\frac{1}{C_{OSC} \cdot R1}\right) \right] \dots\dots\dots (1)$$

Assuming that VOSC = 1.4 V (t = t1) and = 2.85 V (t = t2)

COSC is external capacitance connected to pin (4) and R1 is on-chip 10 kΩresistor.

Therefore, OSC frequency is calculated as follows.

$$t_1 = -C_{OSC} R1 \cdot \ln \left(1 - \frac{1.4}{5} \right) \dots\dots\dots (2)$$

$$t_2 = -C_{OSC} R1 \cdot \ln \left(1 - \frac{2.85}{5} \right) \dots\dots\dots (3)$$

$$f_{OSC} = \frac{1}{t_2 - t_1} = \frac{1}{C_{OSC} \left(R1 \cdot \ln \left(1 - \frac{1.4}{5} \right) - R1 \cdot \ln \left(1 - \frac{2.85}{5} \right) \right)}$$

$$= \frac{1}{5.15 \cdot C_{OSC}} \text{ (kHz) (COSC : } \mu\text{F)}$$

勝特力材料 886-3-5753170
胜特力电子(上海) 86-21-54151736
胜特力电子(深圳) 86-755-83298787
Http://www.100y.com.tw

ENABLE AND RESET FUNCTION AND \overline{MO} SIGNAL

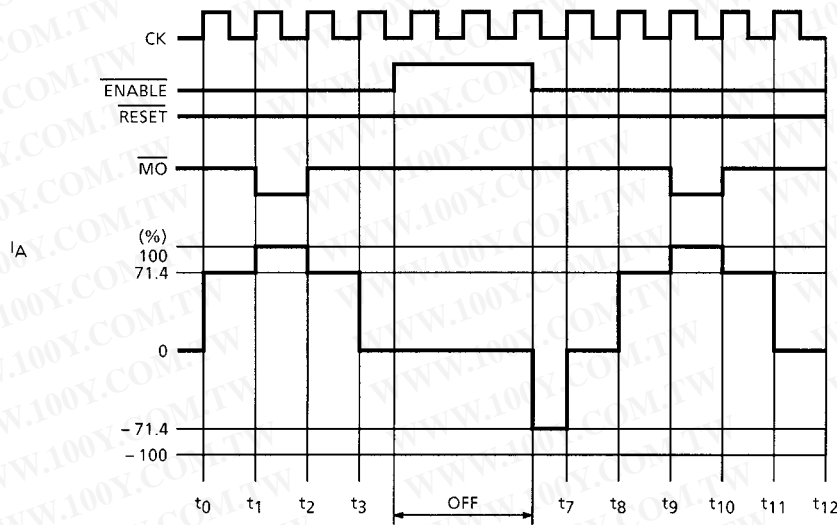

Fig.1 1-2 Phase drive mode (M1: H, M2: L)

\overline{ENABLE} Signal disables only Output Signal.

Internal logic functions are proceeded by CK signal without regard to \overline{ENABLE} signal.

Therefore, Output Current is initiated from the proceeded timing point of internal logic circuit after release of disable mode.

Fig.1 shows the \overline{ENABLE} functions, when the system is selected in 1-2 Phase drive mode.

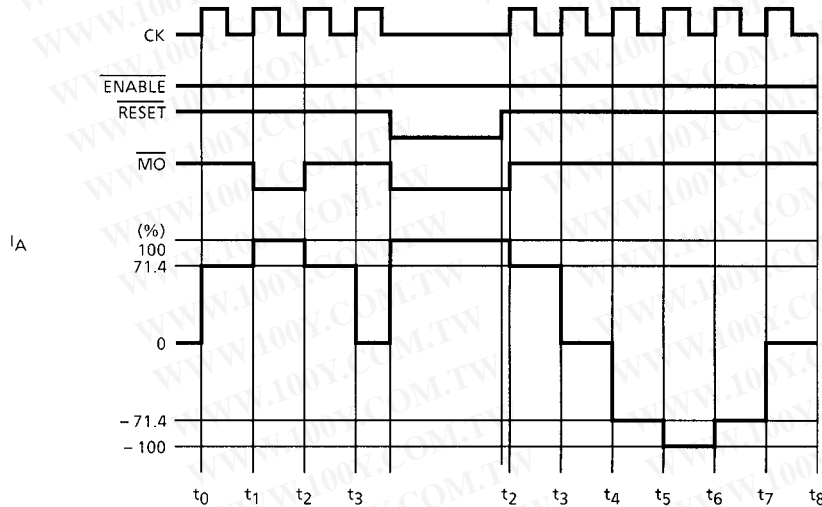

Fig.2 1-2 Phase drive mode (M1: H, M2: L)

Low level active of \overline{RESET} Signal offs not only the Outputs but also stops internal CK functions and \overline{MO} to low. Outputs are initiated from the initial point after release of \overline{RESET} (High) as shown in Fig.2.

\overline{MO} (Monitor Output) Signals can be used as rotation and initial signal for stable rotation checking.

勝特力材料 886-3-5753170
 勝特力电子(上海) 86-21-54151736
 勝特力电子(深圳) 86-755-83298787
[Http://www.100y.com.tw](http://www.100y.com.tw)

FUNCTION

INPUT					MODE
CK1	CK2	CW / CCW	RESET	ENABLE	
	H	L	H	L	CW
	L	L	H	L	INHIBIT (Note)
H		L	H	L	CCW
L		L	H	L	INHIBIT (Note)
	H	H	H	L	CCW
	L	H	H	L	INHIBIT (Note)
H		H	H	L	CW
L		H	H	L	INHIBIT (Note)
X	X	X	L	L	RESET
X	X	X	X	H	Z

INITIAL MODE

EXCITATION MODE	A PHASE CURRENT	B PHASE CURRENT
2 Phase	100%	-100%
1-2 Phase	100%	0%
W1-2 Phase	100%	0%
2W1-2 Phase	100%	0%

Z: High impedance

X: Don't Care

INPUT		MODE (EXCITATION)
M1	M2	
L	L	2 Phase
H	L	1-2 Phase
L	H	W1-2 Phase
H	H	2W1-2 Phase

勝特力材料 886-3-5753170
 勝特力电子(上海) 86-21-54151736
 勝特力电子(深圳) 86-755-83298787
[Http://www.100y.com.tw](http://www.100y.com.tw)

2 PHASE EXCITATION (M1 : L, M2 : L, CW MODE)

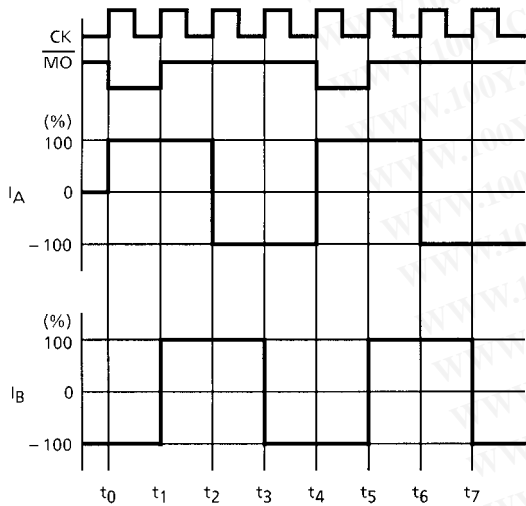

1-2 PHASE EXCITATION (M1 : H, M2 : L, CW MODE)

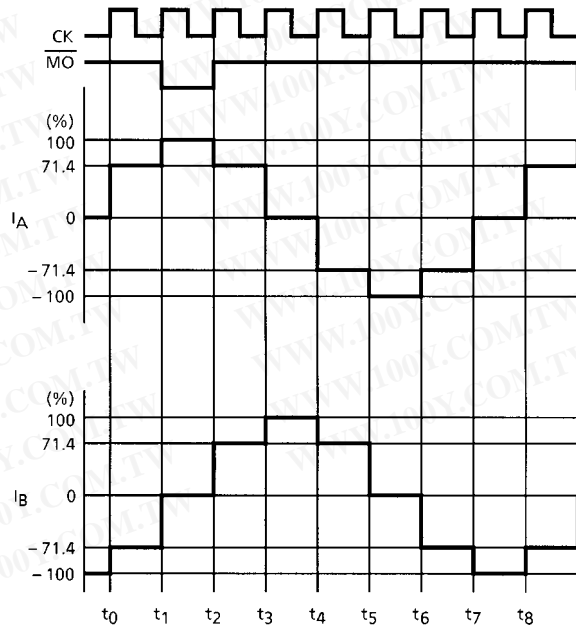

W1-2 PHASE EXCITATION (M1 : L, M2 : H, CW MODE)

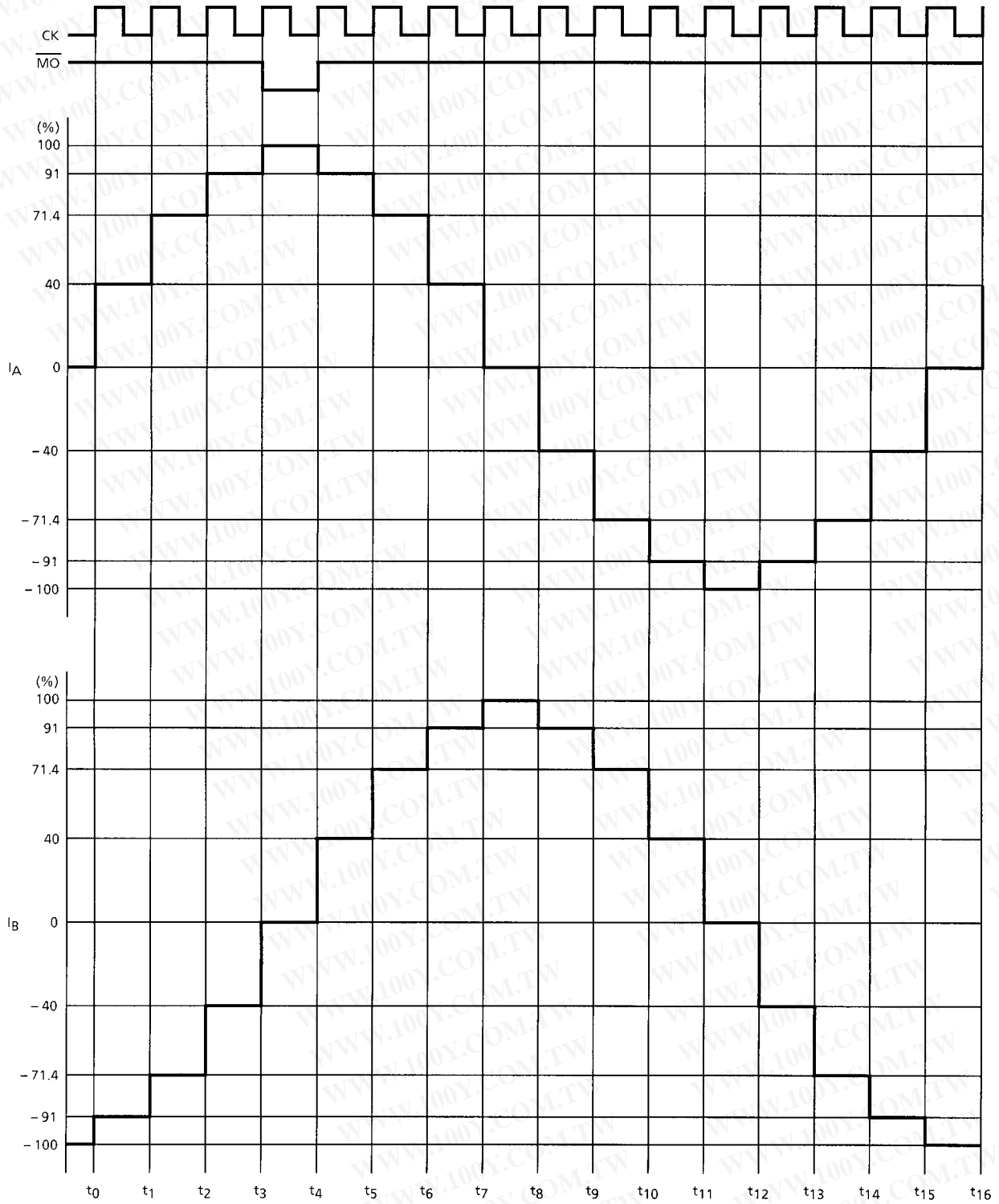

勝特力材料 886-3-5753170
勝特力电子(上海) 86-21-54151736
勝特力电子(深圳) 86-755-83298787
[Http://www.100y.com.tw](http://www.100y.com.tw)

2W1-2 PHASE EXCITATION (M1 : H, M2 : H, CW MODE)

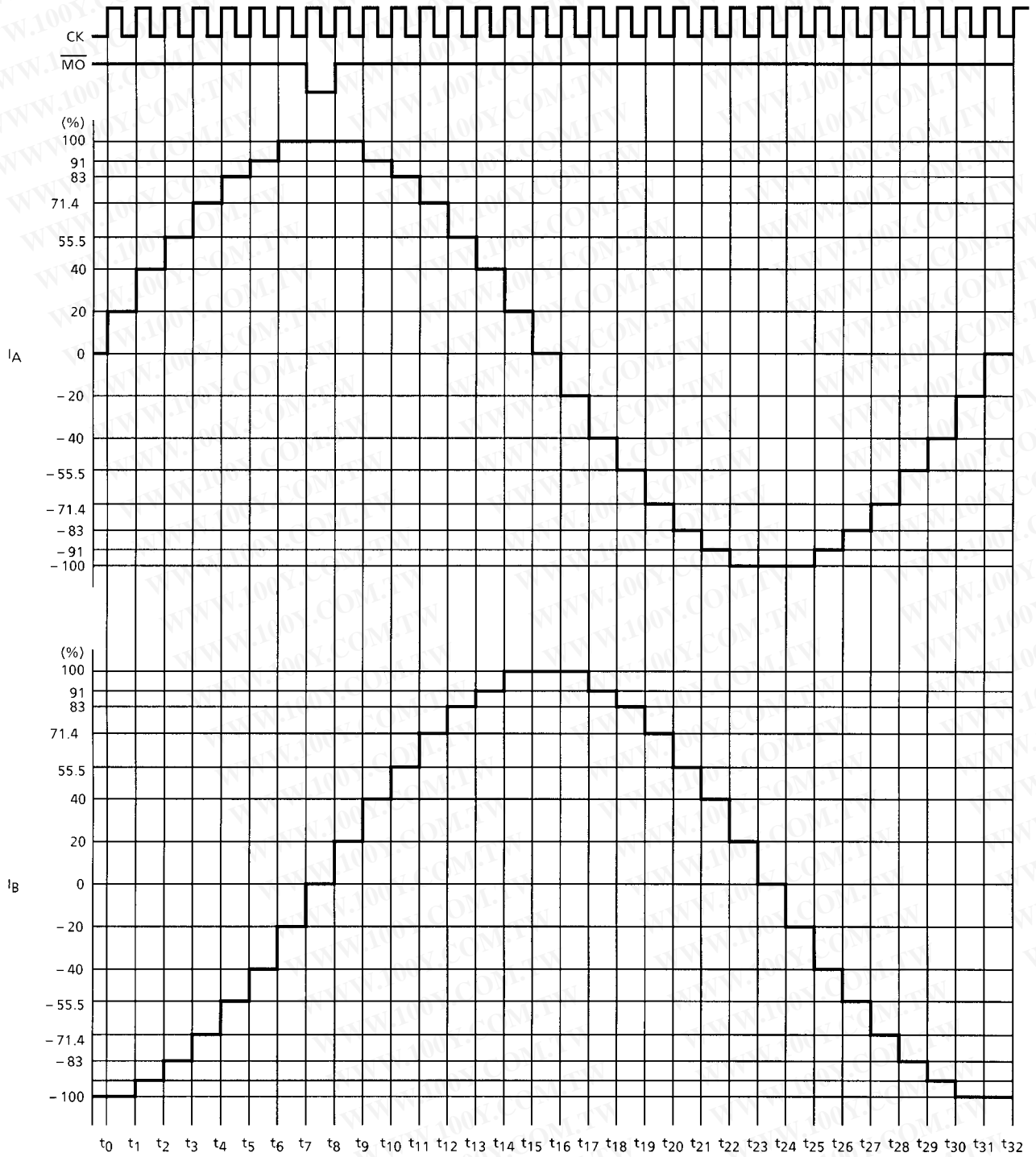

勝特力材料 886-3-5753170
勝特力电子(上海) 86-21-54151736
勝特力电子(深圳) 86-755-83298787
[Http://www.100y.com.tw](http://www.100y.com.tw)

MAXIMUM RATINGS (Ta = 25°C)

CHARACTERISTIC		SYMBOL	RATING	UNIT
Supply Voltage		V _{CC}	5.5	V
Output Voltage		V _M	40	V
Output Current	PEAK	I _O (PEAK)	2.5	A
	AVE	I _O (AVE.)	1.5	
MO Output Current		I _O (MO)	±2	mA
Input Voltage		V _{IN}	~V _{CC}	V
Power Dissipation		P _D	5 (Note 1)	W
			43 (Note 2)	
Operating Temperature		T _{opr}	-40~85	°C
Storage Temperature		T _{stg}	-55~150	°C
Feed Back Voltage		V _{NF}	1.0	V

Note 1: No heat sink

Note 2: T_c = 85°C

RECOMMENDED OPERATING CONDITIONS (Ta = -20~75°C)

CHARACTERISTIC	SYMBOL	TEST CONDITION	MIN	TYP.	MAX	UNIT
Supply Voltage	V _{CC}	—	4.5	5.0	5.5	V
Output Voltage	V _M	—	21.6	24	26.4	V
Output Current	I _{OUT}	—	—	—	1.5	A
Input Voltage	V _{IN}	—	—	—	V _{CC}	V
Clock Frequency	f _{CK}	—	—	—	5	kHz
OSC Frequency	f _{OSC}	—	15	—	80	kHz

勝特力材料 886-3-5753170
 勝特力电子(上海) 86-21-54151736
 勝特力电子(深圳) 86-755-83298787
[Http://www.100y.com.tw](http://www.100y.com.tw)

ELECTRICAL CHARACTERISTICS (Ta = 25°C, VCC = 5 V, VM = 24 V)

CHARACTERISTIC		SYMBOL	TEST CIR-CUIT	TEST CONDITION	MIN	TYP.	MAX	UNIT	
Input Voltage	High	V _{IN} (H)	1	M1, M2, CW / CCW, REF IN ENABLE, CK1, CK2 RESET	3.5	—	V _{CC} + 0.4	V	
	Low	V _{IN} (L)			GND -0.4	—	1.5		
Input Hysteresis Voltage		V _H			—	600	—	mV	
Input Current		I _{IN-1} (H)	1	M1, M2, REF IN, V _{IN} = 5.0 V	—	—	100	nA	
		I _{IN-1} (L)		RESET, ENABLE, V _{IN} = 0 V INTERNAL PULL-UP RESISTOR	10	50	100	μA	
		I _{IN-2} (L)		SOURCE TYPE, V _{IN} = 0 V	—	—	100	nA	
Quiescent Current V _{CC} Terminal		I _{CC1}	1	Output Open, RESET : H ENABLE : L (2, 1-2 Phase excitation)	—	10	18	mA	
		I _{CC2}		Output Open, RESET : H ENABLE : L (W1-2, 2W1-2 Phase excitation)	—	10	18		
		I _{CC3}		RESET : L, ENABLE : H	—	5	—		
		I _{CC4}		RESET : H, ENABLE : H	—	5	—		
Comparator Reference Voltage	High	V _{NF} (H)	3	REF IN H Output Open	(Note)	0.72	0.8	0.88	V
	Low	V _{NF} (L)		REF IN L Output Open		0.45	0.5	0.55	
Output Differential		ΔV _O	—	B / A, C _{OSC} = 0.0033 μF, R _{NF} = 0.8 Ω	-10	—	10	%	
V _{NF} (H) - V _{NF} (L)		ΔV _{NF}	—	V _{NF} (L) / V _{NF} (H) C _{OSC} = 0.0033 μF, R _{NF} = 0.8 Ω	56	63	70	%	
NF Terminal Current		I _{NF}	—	SOURCE TYPE	—	170	—	μA	
Maximum OSC Frequency		f _{OSC} (MAX.)	—	—	100	—	—	kHz	
Minimum OSC Frequency		f _{OSC} (MIN.)	—	—	—	—	10	kHz	
OSC Frequency		f _{OSC}	—	C _{OSC} = 0.0033 μF	25	44	62	kHz	
Minimum Clock Pulse Width		t _W (CK)	—	—	—	1.0	—	μs	
Output Voltage	V _{OH} (MO)	—	—	I _{OH} = -40 μA	4.5	4.9	V _{CC}	V	
	V _{OL} (MO)			I _{OL} = 40 μA	GND	0.1	0.5		

Note: 2 Phase excitation, R_{NF} = 0.7 Ω, C_{OSC} = 0.0033 μF

勝特力材料 886-3-5753170
 勝特力电子(上海) 86-21-54151736
 勝特力电子(深圳) 86-755-83298787
[Http://www.100y.com.tw](http://www.100y.com.tw)

OUTPUT BLOCK

CHARACTERISTIC			SYMBOL	TEST CIR-CUIT	TEST CONDITION	MIN	TYP.	MAX	UNIT					
Output Saturation Voltage	Upper Side		$V_{SAT U1}$	4	$I_{OUT} = 1.5 A$	—	2.1	2.8	V					
	Lower Side		$V_{SAT L1}$			—	1.3	2.0						
	Upper Side		$V_{SAT U2}$		$I_{OUT} = 0.8 A$	—	1.8	2.2						
	Lower Side		$V_{SAT L2}$			—	1.1	1.5						
	Upper Side		$V_{SAT U3}$		$I_{OUT} = 2.5 A$ Pulse width 30 ms	—	2.5	3.0						
	Lower Side		$V_{SAT L3}$			—	1.8	2.2						
Diode Forward Voltage	Upper Side		$V_F U1$	5	$I_{OUT} = 1.5 A$	—	2.0	3.0	V					
	Lower Side		$V_F L1$			—	1.5	2.1						
	Upper Side		$V_F U2$		$I_{OUT} = 2.5 A$ Pulse width 30 ms	—	2.5	3.3						
	Lower Side		$V_F L2$			—	1.8	2.5						
Output Dark Current (A + B Channels)			I_{M1}	2	ENABLE : "H" Level, Output Open RESET : "L" Level	—	—	50	μA					
			I_{M2}		ENABLE : "L" Level Output Open RESET : "H" Level	—	8	15	mA					
A-B Chopping Current (Note)	2W1-2 ϕ	W1-2 ϕ	1-2 ϕ	VECTOR	—	$\theta = 0$	REF IN : H $R_{NF} = 0.8 \Omega$ $C_{OSC} = 0.0033 \mu F$	—	100	—	%			
	2W1-2 ϕ	—	—					$\theta = 1 / 8$	—	100		—		
	2W1-2 ϕ	W1-2 ϕ	—					$\theta = 2 / 8$	86	91		96		
	2W1-2 ϕ	—	—					$\theta = 3 / 8$	78	83		88		
	2W1-2 ϕ	W1-2 ϕ	1-2 ϕ					$\theta = 4 / 8$	66.4	71.4		76.4		
	2W1-2 ϕ	—	—					$\theta = 5 / 8$	50.5	55.5		60.5		
	2W1-2 ϕ	W1-2 ϕ	—					$\theta = 6 / 8$	35	40		45		
	2W1-2 ϕ	—	—					$\theta = 7 / 8$	15	20		25		
	2 Phase Excitation Mode VECTOR									—		—	100	—

Note: Maximum current ($\theta = 0$): 100%
 2W1-2 ϕ : 2W1, 2 phase excitation mode
 W1-2 ϕ : W1, 2 phase excitation mode
 1-2 ϕ : 1, 2 phase excitation mode

勝特力材料 886-3-5753170
勝特力电子(上海) 86-21-54151736
勝特力电子(深圳) 86-755-83298787
[Http://www.100y.com.tw](http://www.100y.com.tw)

CHARACTERISTIC			SYMBOL	TEST CIR-CUIT	TEST CONDITION	MIN	TYP.	MAX	UNIT					
A-B Chopping Current (Note)	2W1-2φ	W1-2φ	1-2φ	VECTOR	—	REF IN : H R _{NF} = 0.8 Ω C _{OSC} = 0.0033 μF	—	100	—	%				
	2W1-2φ	—	—								θ = 0	—	100	—
	2W1-2φ	—	—								θ = 1 / 8	—	100	—
	2W1-2φ	W1-2φ	—								θ = 2 / 8	86	91	96
	2W1-2φ	—	—								θ = 3 / 8	78	83	88
	2W1-2φ	W1-2φ	1-2φ								θ = 4 / 8	66.4	71.4	76.4
	2W1-2φ	—	—								θ = 5 / 8	50.5	55.5	60.5
	2W1-2φ	W1-2φ	—								θ = 6 / 8	35	40	45
	2W1-2φ	—	—								θ = 7 / 8	15	20	25
2 Phase Excitation Mode VECTOR				—	—	100	—							
Feed Back Voltage Step			ΔV _{NF}	—	Δθ = 0 / 8 - 1 / 8	REF IN : H R _{NF} = 0.8 Ω C _{OSC} = 0.0033 μF	—	0	—	mV				
					Δθ = 1 / 8 - 2 / 8		32	72	112					
					Δθ = 2 / 8 - 3 / 8		24	64	104					
					Δθ = 3 / 8 - 4 / 8		53	93	133					
					Δθ = 4 / 8 - 5 / 8		87	127	167					
					Δθ = 5 / 8 - 6 / 8		84	124	164					
					Δθ = 6 / 8 - 7 / 8		120	160	200					
Output T _r Switching Characteristics				7	R _L = 2 Ω, V _{NF} = 0 V, C _L = 15 pF		t _r	—	0.3	—	μs			
							t _f	—	2.2	—				
							t _{pLH}	CK~Output	—	1.5		—		
							t _{pHL}		—	2.7		—		
							t _{pLH}	OSC~Output	—	5.4		—		
							t _{pHL}		—	6.3		—		
							t _{pLH}	RESET ~Output	—	2.0		—		
							t _{pHL}		—	2.5		—		
							t _{pLH}	ENABLE ~Output	—	5.0		—		
t _{pHL}	—	6.0	—											
Output Leakage Current	Upper Side	I _{OH}	6	V _M = 30 V	—	—	50	μA						
	Lower Side	I _{OL}			—	—	50							

Note: Maximum current (θ = 0): 100%
 2W1-2φ: 2W1, 2 phase excitation mode
 W1-2φ : W1, 2 phase excitation mode
 1-2φ : 1, 2 phase excitation mode

勝特力材料 886-3-5753170
 勝特力电子(上海) 86-21-54151736
 勝特力电子(深圳) 86-755-83298787
[Http://www.100y.com.tw](http://www.100y.com.tw)

TEST CIRCUIT 1

V_{IN} (H), (L), I_{IN} (H), (L)

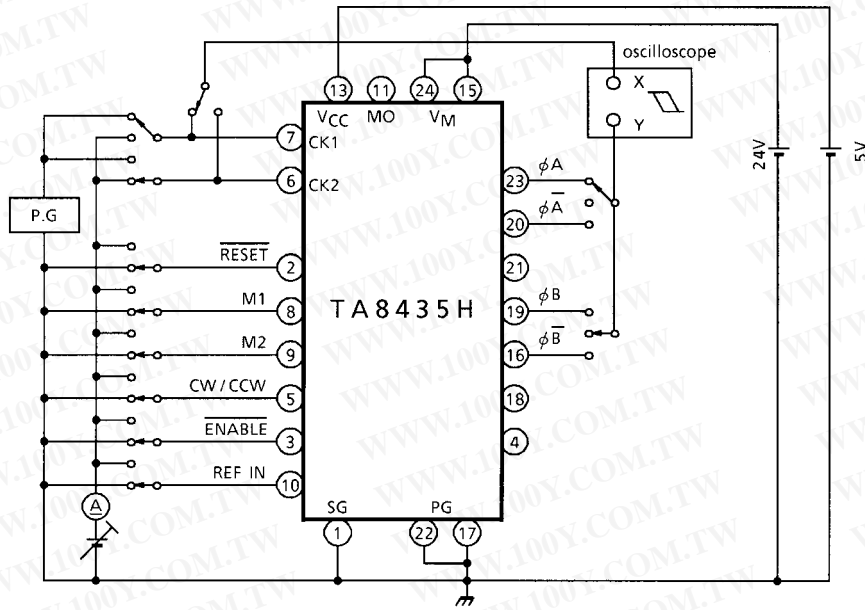

TEST CIRCUIT 2

I_{CC} , I_M

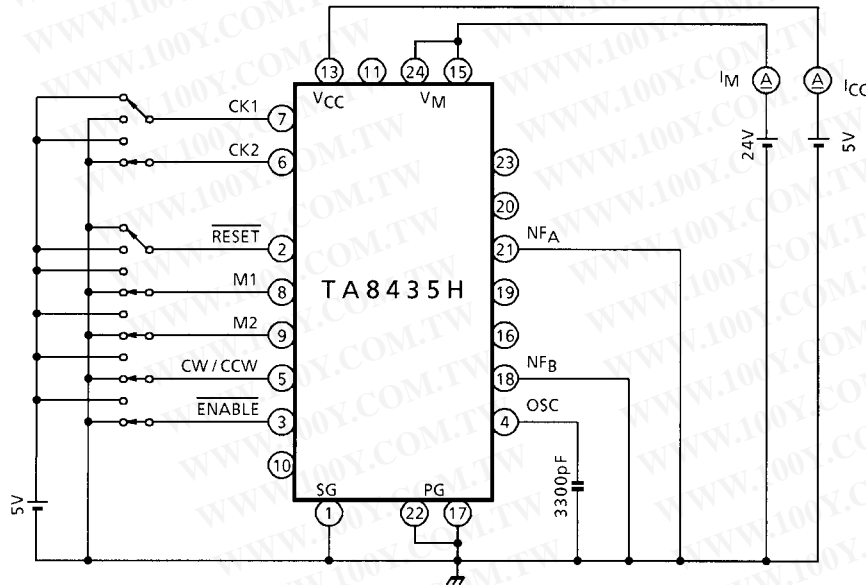

勝特力材料 886-3-5753170
 勝特力电子(上海) 86-21-54151736
 勝特力电子(深圳) 86-755-83298787
[Http://www.100y.com.tw](http://www.100y.com.tw)

TEST CIRCUIT 3

$V_{NF}(H), (L)$

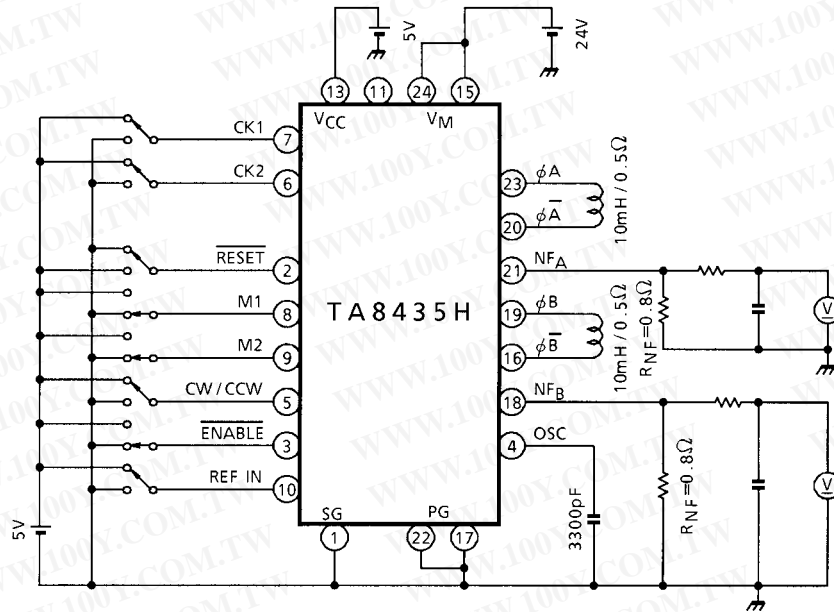

TEST CIRCUIT 4

$V_{CE}(SAT)$ UPPER SIDE, LOWER SIDE

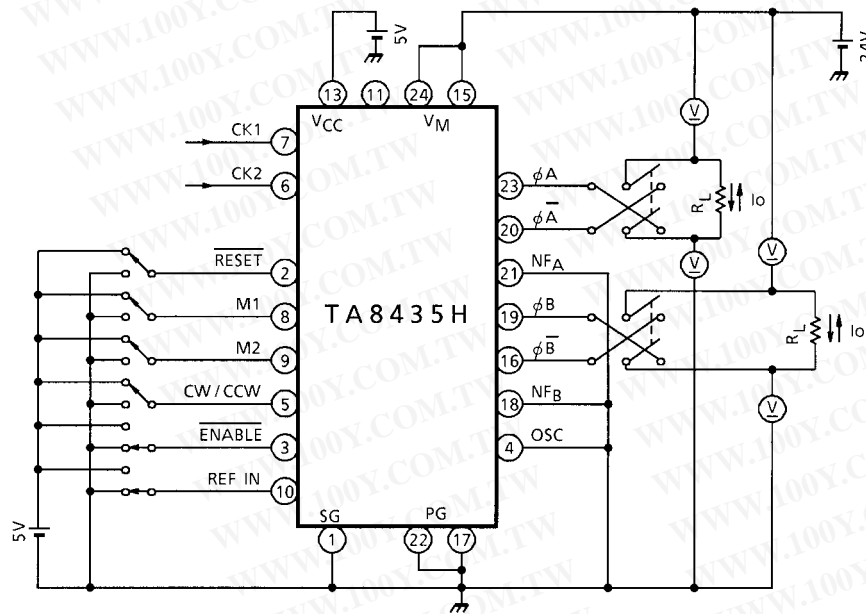

Note: Calibrate I_o to 1.5 A / 0.8 A by R_L

勝特力材料 886-3-5753170
 勝特力电子(上海) 86-21-54151736
 勝特力电子(深圳) 86-755-83298787
[Http://www.100y.com.tw](http://www.100y.com.tw)

TEST CIRCUIT 5

V_{FU} , V_{FL}

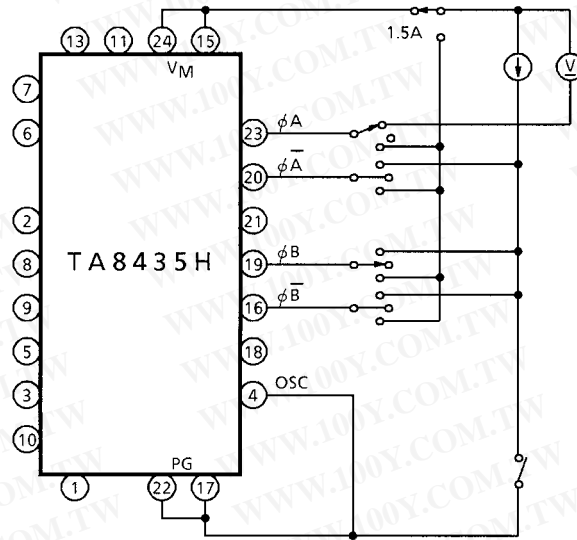

TEST CIRCUIT 6

I_{OH} , I_{OL}

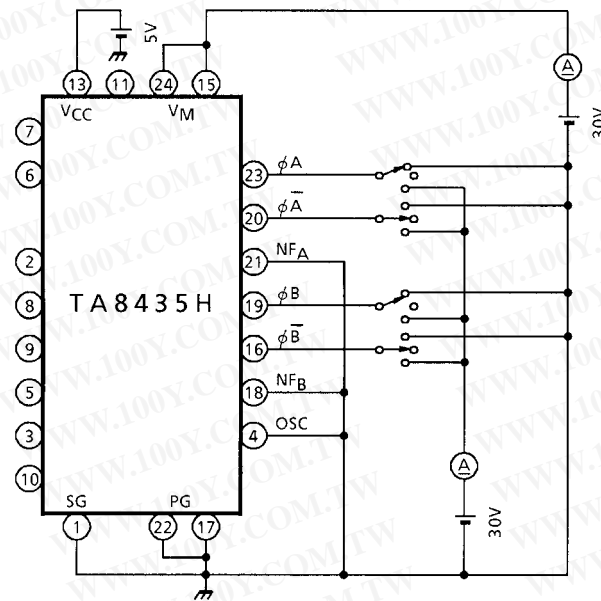

勝特力材料 886-3-5753170
 勝特力电子(上海) 86-21-54151736
 勝特力电子(深圳) 86-755-83298787
[Http://www.100y.com.tw](http://www.100y.com.tw)

AC ELECTRICAL CHARACTERISTICS, MEASUREMENT WAVE CK (OSC)-OUT

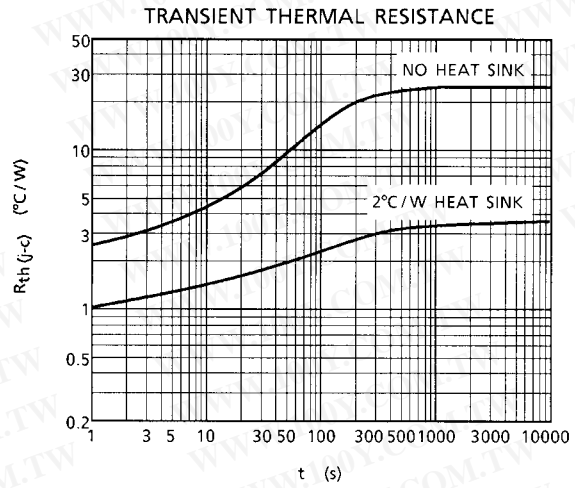
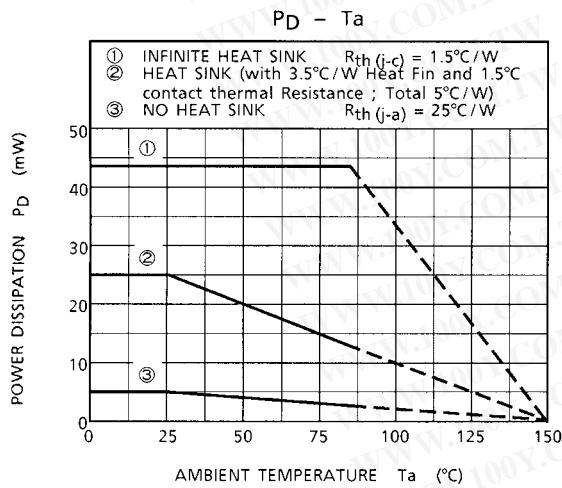
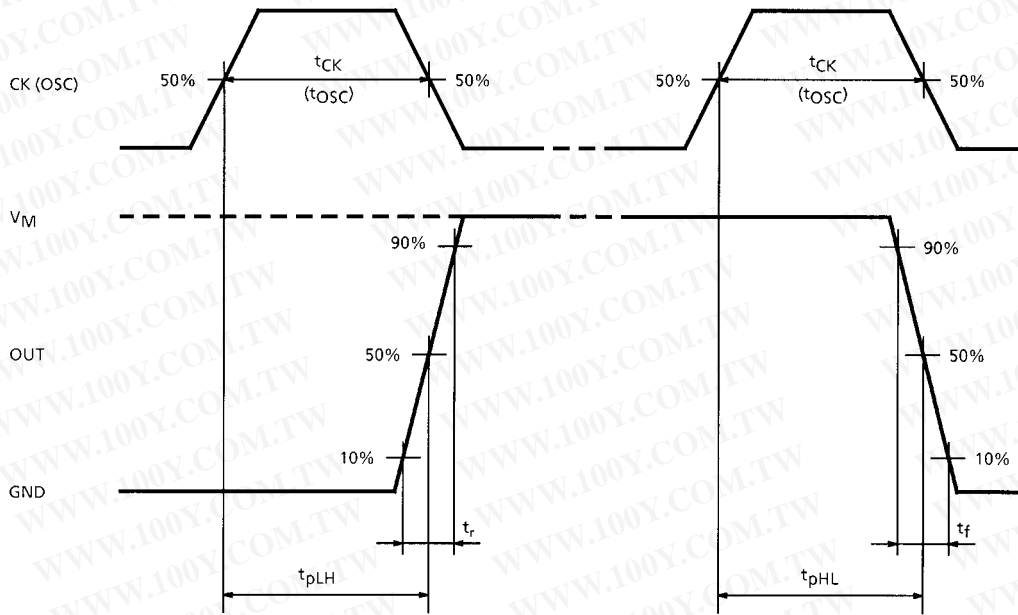

勝特力材料 886-3-5753170
勝特力电子(上海) 86-21-54151736
勝特力电子(深圳) 86-755-83298787
[Http://www.100y.com.tw](http://www.100y.com.tw)

OUTPUT CURRENT VECTOR ORBIT (Normalize to 90° for each one step)

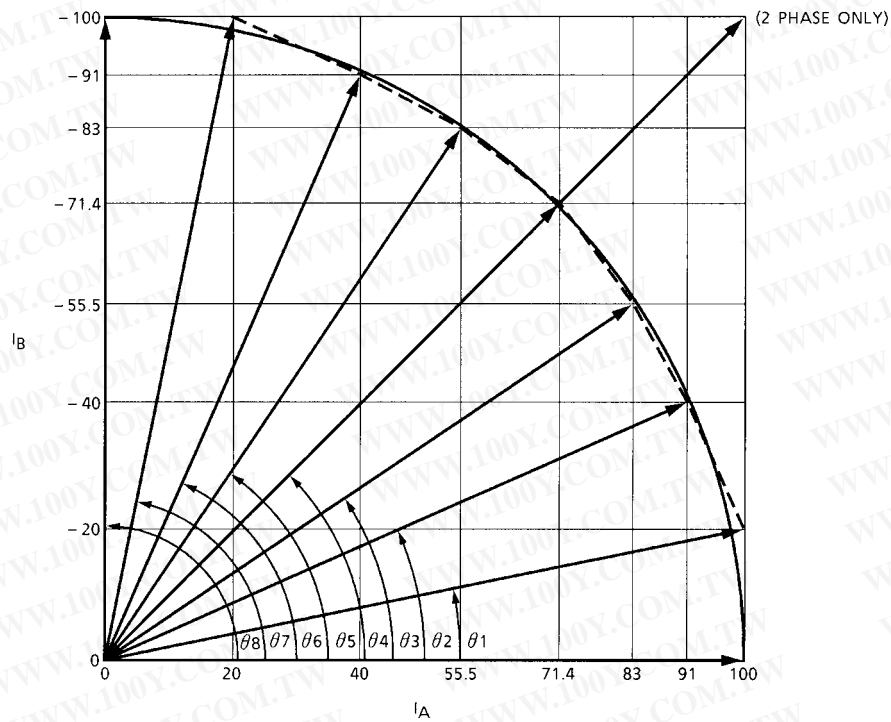

θ	ROTATION ANGLE		VECTOR LENGTH		
	IDEAL	TA8435H	IDEAL	TA8435H	
θ_0	0°	0°	100	100.00	—
θ_1	11.25°	11.31°	100	101.98	—
θ_2	22.5°	23.73°	100	99.40	—
θ_3	33.75°	33.77°	100	99.85	—
θ_4	45°	45°	100	100.97	141.42
θ_5	56.25°	56.23°	100	99.85	—
θ_6	67.5°	66.27°	100	99.40	—
θ_7	78.75°	78.69°	100	101.98	—
θ_8	90°	90°	100	100.00	—
				1-2 / W1-2 / 2W1-2 Phase	2 Phase

勝特力材料 886-3-5753170
勝特力电子(上海) 86-21-54151736
勝特力电子(深圳) 86-755-83298787
[Http://www.100y.com.tw](http://www.100y.com.tw)

APPLICATION CIRCUIT

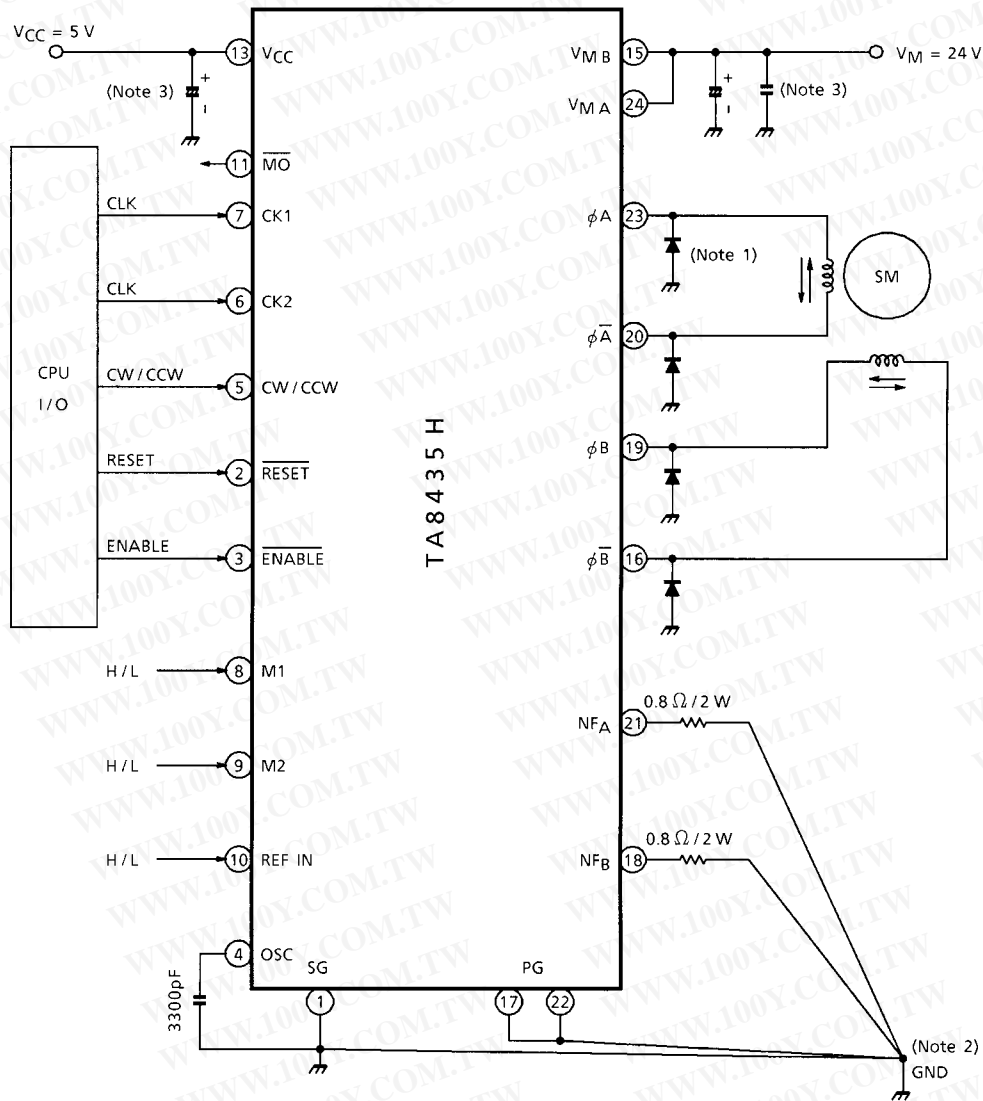

- Note 1: Schottky diode (3GWJ42) to be connected additionally between each output (pin 16 / 19 / 20 / 23) and GND for preventing Punch-Through Current
- Note 2: GND pattern to be laid out at one point in order to prevent common impedance.
- Note 3: Capacitor for noise suppression to be connected between the Power Supply (V_{CC} , V_M) and GND to stabilize the operation.
- Note 4: Utmost care is necessary in the design of the output line, V_M and GND line since IC may be destroyed due to short-circuit between outputs, air contamination fault, or fault by improper grounding.

勝特力材料 886-3-5753170
 勝特力电子(上海) 86-21-54151736
 勝特力电子(深圳) 86-755-83298787
[Http://www.100y.com.tw](http://www.100y.com.tw)

When using TA8435H

0. Introduction

The TA8435H controls PWM to set the stepping motor winding current to constant current. The device is a micro-step driver IC used to efficiently drive the stepping motor at low vibration.

1. About micro-step drive

The TA8435H drives a stepping motor in micro steps with a maximum resolution of 1 / 8 of the 2-phase stepping angle (in 2W1-2 phase mode).

In micro steps, A-phase and B-phase current levels are set inside the IC so that the composite vector size and the rotation angle are even. Just inputting clock signals rotates the stepping motor in micro steps.

2. About PWM control and output current setting

(1) Output current path (PWM control)

The TA8435H controls PWM by turning the upper power transistor on / off. In such a case, current flows as shown in the figure below.

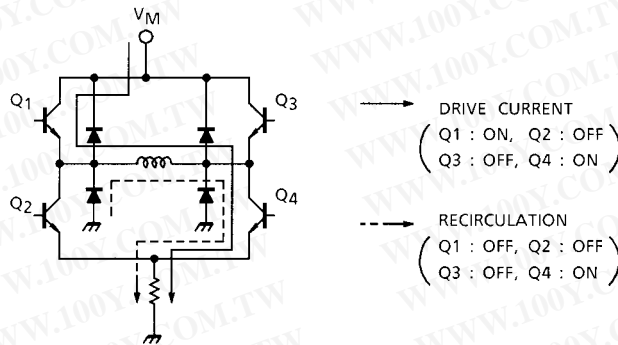

(2) Setting of output current by REF-IN input and current detection resistor

The motor current (maximum current for micro-step drive) I_O is set as shown in the following equation, using REF-IN input and the external current detection resistor RNF.

$$I_O = V_{REF} / R_{NF}$$

where,

$$\text{REF - IN} = \text{High}, \quad V_{REF} = 0.8 \text{ V}$$

$$\text{REF - IN} = \text{Low}, \quad V_{REF} = 0.5 \text{ V}$$

勝特力材料 886-3-5753170
 勝特力电子(上海) 86-21-54151736
 勝特力电子(深圳) 86-755-83298787
[Http://www.100y.com.tw](http://www.100y.com.tw)

3. Logic control

(1) Clock input for rotation direction control

To switch rotation between forward and reverse, there are two clock input types: 1-clock input and 2-clock input.

(a) 1-clock input

Uses either clock pin CK1 or CK2.

Switches rotation between forward or reverse using the CW or CCW signal.

<Input signal example: 1-2 phase mode>

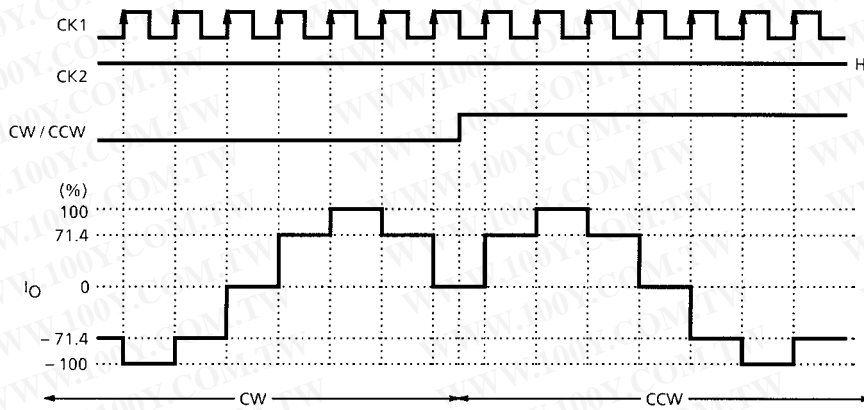

(b) 2-clock input

Uses both clock pins CK1 and CK2.

Switching between CK1 and CK2 controls forward / reverse rotation.

<Input signal example: 1-2 phase mode>

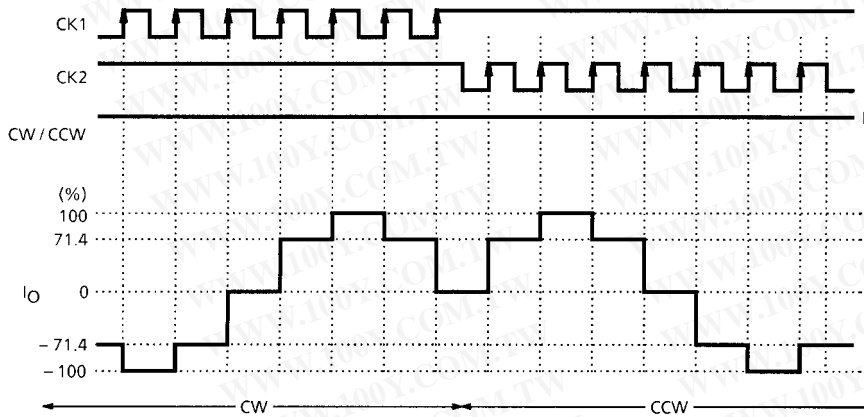

勝特力材料 886-3-5753170
 勝特力电子(上海) 86-21-54151736
 勝特力电子(深圳) 86-755-83298787
[Http://www.100y.com.tw](http://www.100y.com.tw)

- (2) Mode setting
Setting M1 and M2 selects one of the following modes: 2-phase, 1-2 phase, W1-2 phase, and 2W1-2 phase modes.
- (3) Monitor (\overline{MO}) output
Supports the monitor output used to monitor the current waveform location.
For 2-phase mode, \overline{MO} output is Low at the timing of A-phase current = 100% and B-phase current = -100%.
For 1-2 phase, W1-2 phase, or 2W1-2 phase mode, \overline{MO} output is Low at the timing of A-phase current = 100% and B-phase current = 0%.
- (4) Reset pin
Supports reset input used to reset the internal counter.
Setting RESET to Low resets the internal counter, forcing the output current to the same value as that when the \overline{MO} output is Low.
- (5) Phase mode switching
To avoid the step changing during motor rotation, current must not fluctuate at phase mode switching. Pay attention to the following points.
 - (a) When switching between 2-phase and other phase modes, current fluctuates.
 - (b) When switching between phase modes other than 2-phase, current can be switched without fluctuation at the timing of \overline{MO} output = Low.
However, when switching as follows, set RESET to Low beforehand:
From 1-2 phase to W1-2 phase or 2W1-2 phase mode
From W1-2 phase to 2W1-2 phase mode

<Example of Input Signal>

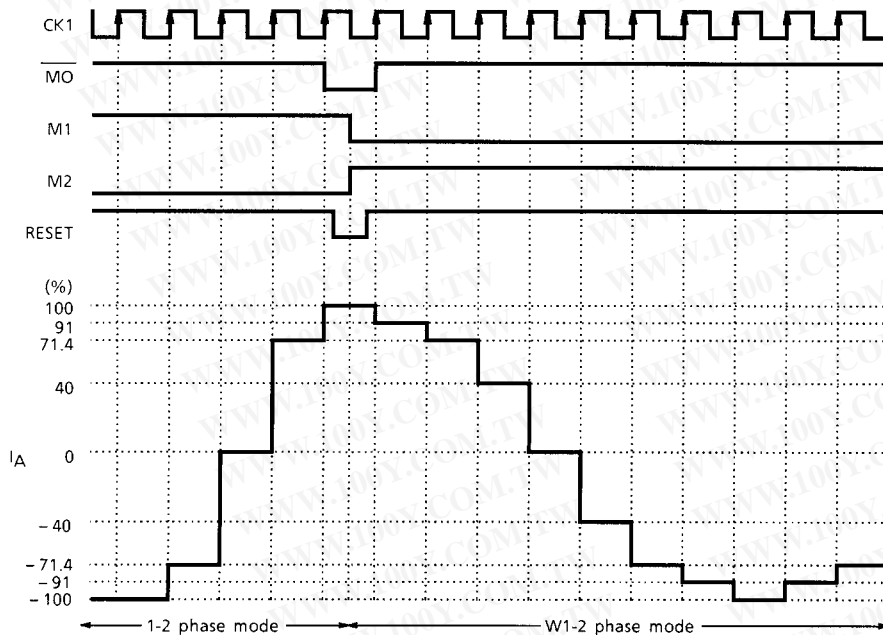

勝特力材料 886-3-5753170
 勝特力电子(上海) 86-21-54151736
 勝特力电子(深圳) 86-755-83298787
[Http://www.100y.com.tw](http://www.100y.com.tw)

4. About PWM oscillation frequency (external capacitor setting)

An external capacitor connected to the OSC pin is used to internally generate a sawtooth waveform. PWM is controlled using this frequency. Toshiba recommend 3300 pF for the capacitance by taking variation between ICs into consideration.

5. About external Schottky diode

A parasitic diode is created on the lower side of the output. When PWM is controlled, current flows to the parasitic diode. This current results in a punch-through current and micro-step waveform fluctuation. Therefore, make sure to externally connect a Schottky barrier diode. The external diode can reduce heat generated in the IC.

6. Power dissipation

The IC power dissipation is determined by the following equation (In a case where shottky diode is connected between Output pin and GND):

$$P = V_{CC} \times I_{CC} + V_M \times I_M + I_O (t_{ON} \times V_{SAT-U} + V_{SAT-L})$$
$$t_{ON} = T_{ON} / T_S \text{ (PWM control ON duty)}$$

The higher the ambient temperature, the smaller the power dissipation. Check the PD-Ta curve and design heat dissipation with a sufficient margin.

7. About heatsink fin processing

The IC fin (rear) is electrically connected to the rear of the chip. When current flows to the fin, the IC malfunctions. If there is any possibility of a voltage being generated between the IC GND and the fin, either ground the fin or insulate it.

勝特力材料 886-3-5753170
勝特力电子(上海) 86-21-54151736
勝特力电子(深圳) 86-755-83298787
[Http://www.100y.com.tw](http://www.100y.com.tw)

PACKAGE DIMENSIONS

HZIP25-P-1.27

Unit: mm

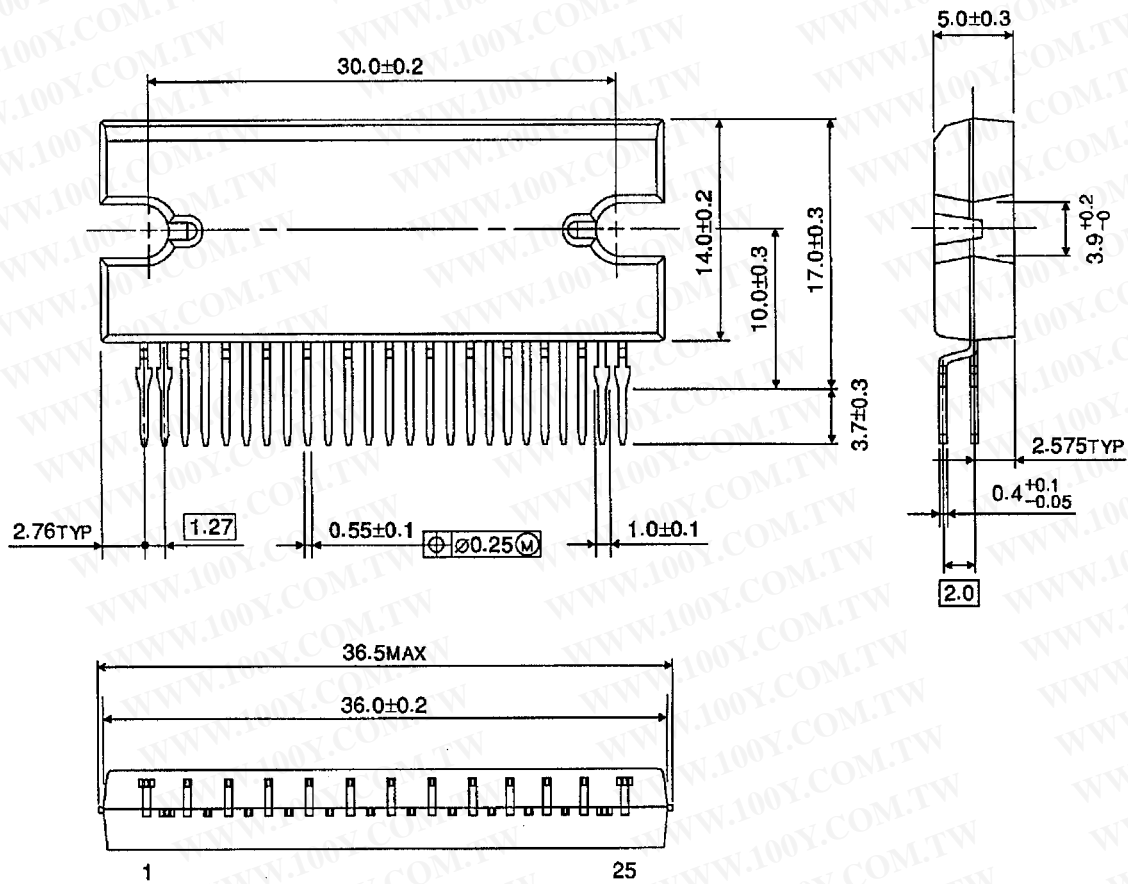

Weight: 9.86 g (Typ.)

勝特力材料 886-3-5753170
 勝特力电子(上海) 86-21-54151736
 勝特力电子(深圳) 86-755-83298787
[Http://www.100y.com.tw](http://www.100y.com.tw)

勝特力材料 886-3-5753170
勝特力电子(上海) 86-21-54151736
勝特力电子(深圳) 86-755-83298787
[Http://www.100y.com.tw](http://www.100y.com.tw)

RESTRICTIONS ON PRODUCT USE

000707EBA

- TOSHIBA is continually working to improve the quality and reliability of its products. Nevertheless, semiconductor devices in general can malfunction or fail due to their inherent electrical sensitivity and vulnerability to physical stress. It is the responsibility of the buyer, when utilizing TOSHIBA products, to comply with the standards of safety in making a safe design for the entire system, and to avoid situations in which a malfunction or failure of such TOSHIBA products could cause loss of human life, bodily injury or damage to property.
In developing your designs, please ensure that TOSHIBA products are used within specified operating ranges as set forth in the most recent TOSHIBA products specifications. Also, please keep in mind the precautions and conditions set forth in the "Handling Guide for Semiconductor Devices," or "TOSHIBA Semiconductor Reliability Handbook" etc..
- The TOSHIBA products listed in this document are intended for usage in general electronics applications (computer, personal equipment, office equipment, measuring equipment, industrial robotics, domestic appliances, etc.). These TOSHIBA products are neither intended nor warranted for usage in equipment that requires extraordinarily high quality and/or reliability or a malfunction or failure of which may cause loss of human life or bodily injury ("Unintended Usage"). Unintended Usage include atomic energy control instruments, airplane or spaceship instruments, transportation instruments, traffic signal instruments, combustion control instruments, medical instruments, all types of safety devices, etc.. Unintended Usage of TOSHIBA products listed in this document shall be made at the customer's own risk.
- The products described in this document are subject to the foreign exchange and foreign trade laws.
- The information contained herein is presented only as a guide for the applications of our products. No responsibility is assumed by TOSHIBA CORPORATION for any infringements of intellectual property or other rights of the third parties which may result from its use. No license is granted by implication or otherwise under any intellectual property or other rights of TOSHIBA CORPORATION or others.
- The information contained herein is subject to change without notice.