

# SN5486, SN54LS86A, SN54S86 SN7486, SN74LS86A, SN74S86 QUADRUPLE 2-INPUT EXCLUSIVE-OR GATES

SDLS124 - DECEMBER 1972 - REVISED MARCH 1988

- Package Options Include Plastic "Small Outline" Packages, Ceramic Chip Carriers and Flat Packages, and Standard Plastic and Ceramic 300-mil DIPs

- Dependable Texas Instruments Quality and Reliability

SN5486, SN54LS86A, SN54S86 . . . J OR W PACKAGE  
SN7486 . . . N PACKAGE  
SN74LS86A, SN74S86 . . . D OR N PACKAGE

(TOP VIEW)

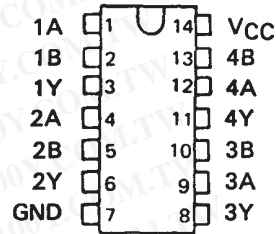

SN54LS86A, SN54S86 . . . FK PACKAGE

(TOP VIEW)

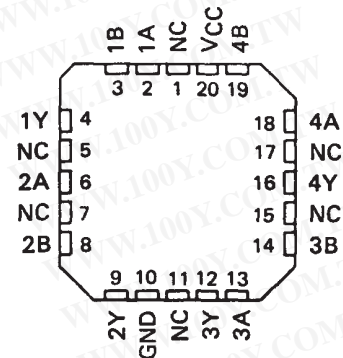

NC - No internal connection

| TYPE   | TYPICAL AVERAGE PROPAGATION DELAY TIME | TYPICAL TOTAL POWER DISSIPATION |
|--------|--|---------------------------------|
| '86    | 14 ns                                  | 150 mW                          |
| 'LS86A | 10 ns                                  | 30.5 mW                         |
| 'S86   | 7 ns                                   | 250 mW                          |

## description

These devices contain four independent 2-input Exclusive-OR gates. They perform the Boolean functions  $Y = A \oplus B = \bar{A}B + A\bar{B}$  in positive logic.

A common application is as a true/complement element. If one of the inputs is low, the other input will be reproduced in true form at the output. If one of the inputs is high, the signal on the other input will be reproduced inverted at the output.

The SN5486, 54LS86A, and the SN54S86 are characterized for operation over the full military temperature range of  $-55^{\circ}\text{C}$  to  $125^{\circ}\text{C}$ . The SN7486, SN74LS86A, and the SN74S86 are characterized for operation from  $0^{\circ}\text{C}$  to  $70^{\circ}\text{C}$ .

## exclusive-OR logic

An exclusive-OR gate has many applications, some of which can be represented better by alternative logic symbols.



These are five equivalent Exclusive-OR symbols valid for an '86 or 'LS86A gate in positive logic; negation may be shown at any two ports.

LOGIC IDENTITY ELEMENT



The output is active (low) if all inputs stand at the same logic level (i.e.,  $A=B$ ).

EVEN-PARITY



The output is active (low) if an even number of inputs (i.e., 0 or 2) are active.

ODD-PARITY ELEMENT

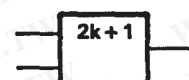

The output is active (high) if an odd number of inputs (i.e., only 1 of the 2) are active.

# SN5486, SN54LS86A, SN54S86 SN7486, SN74LS86A, SN74S86 QUADRUPLE 2-INPUT EXCLUSIVE-OR GATES

SDLS124 – DECEMBER 1972 – REVISED MARCH 1988

## schematics of inputs and outputs

'86

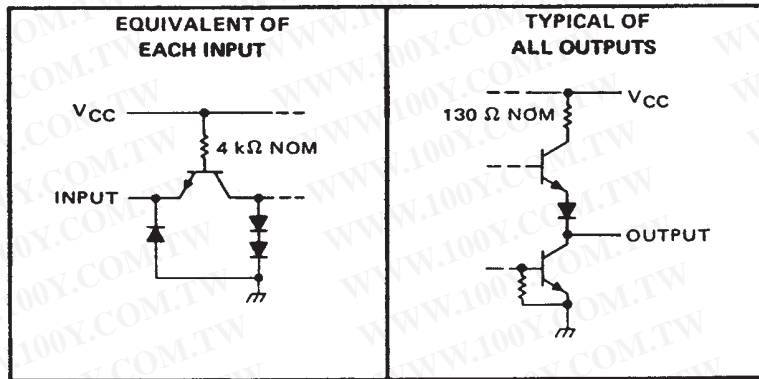

## logic symbol†

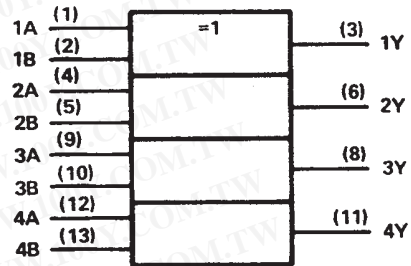

†This symbol is in accordance with ANSI/IEEE Std. 91-1984 and IEC Publication 617-12. Pin numbers shown are for D, J, N, and W packages.

'LS86A

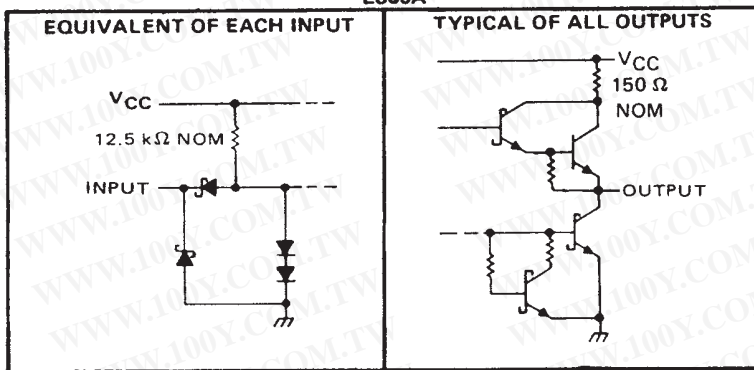

## FUNCTION TABLE

| INPUTS |   | OUTPUT |
|--------|---|--------|
| A      | B | Y      |
| L      | L | L      |
| L      | H | H      |
| H      | L | H      |
| H      | H | L      |

H = high level, L = low level

'S86

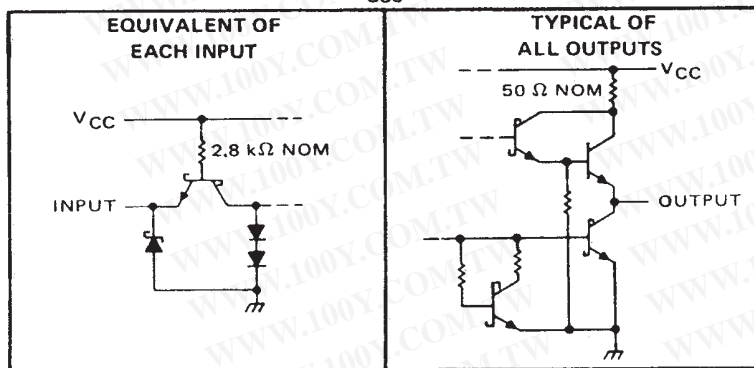

勝特力材料 886-3-5753170  
 勝特力电子(上海) 86-21-54151736  
 勝特力电子(深圳) 86-755-83298787  
[Http://www.100y.com.tw](http://www.100y.com.tw)

absolute maximum ratings over operating free-air temperature range (unless otherwise noted)

|  |                |
|--|----------------|
| Supply voltage, $V_{CC}$ (see Note 1)        | 7 V            |
| Input voltage                                | 5.5 V          |
| Operating free-air temperature range: SN5486 | -55°C to 125°C |
| SN7486                                       | 0°C to 70°C    |
| Storage temperature range                    | -65°C to 150°C |

NOTE 1: Voltage values are with respect to network ground terminal.

recommended operating conditions

|                                       | SN5486 |     |      | SN7486 |     |      | UNIT    |
|---------------------------------------|--------|-----|------|--------|-----|------|---------|
|                                       | MIN    | NOM | MAX  | MIN    | NOM | MAX  |         |
| Supply voltage, $V_{CC}$              | 4.5    | 5   | 5.5  | 4.75   | 5   | 5.25 | V       |
| High-level output current, $I_{OH}$   |        |     | -800 |        |     | -800 | $\mu$ A |
| Low-level output current, $I_{OL}$    |        |     | 16   |        |     | 16   | mA      |
| Operating free-air temperature, $T_A$ | -55    |     | 125  | 0      |     | 70   | °C      |

electrical characteristics over recommended operating free-air temperature range (unless otherwise noted)

| PARAMETER                                    | TEST CONDITIONS†   | SN5486 |      |      | SN7486 |      |      | UNIT    |    |
|--|--|--------|------|------|--------|------|------|---------|----|
|  |  | MIN    | TYP‡ | MAX  | MIN    | TYP‡ | MAX  |         |    |
| $V_{IH}$ High-level input voltage            |  | 2      |      |      | 2      |      |      | V       |    |
| $V_{IL}$ Low-level input voltage             |  |        |      | 0.8  |        |      | 0.8  | V       |    |
| $V_{IK}$ Input clamp voltage                 | $V_{CC} = \text{MIN}, I_I = -8 \text{ mA}$   |        |      | -1.5 |        |      | -1.5 | V       |    |
| $V_{OH}$ High-level output voltage           | $V_{CC} = \text{MIN}, V_{IH} = 2 \text{ V}, V_{IL} = 0.8 \text{ V}, I_{OH} = -800 \mu\text{A}$ | 2.4    | 3.4  |      | 2.4    | 3.4  |      | V       |    |
| $V_{OL}$ Low-level output voltage            | $V_{CC} = \text{MIN}, V_{IH} = 2 \text{ V}, V_{IL} = 0.8 \text{ V}, I_{OL} = 16 \text{ mA}$    |        | 0.2  | 0.4  |        | 0.2  | 0.4  | V       |    |
| $I_I$ Input current at maximum input voltage | $V_{CC} = \text{MAX}, V_I = 5.5 \text{ V}$   |        |      | 1    |        |      | 1    | mA      |    |
| $I_{IH}$ High-level input current            | $V_{CC} = \text{MAX}, V_I = 2.4 \text{ V}$   |        |      | 40   |        |      | 40   | $\mu$ A |    |
| $I_{IL}$ Low-level input current             | $V_{CC} = \text{MAX}, V_I = 0.4 \text{ V}$   |        |      | -1.6 |        |      | -1.6 | mA      |    |
| $I_{OS}$ Short-circuit output current§       | $V_{CC} = \text{MAX}$  |        |      | -20  |        | -55  | -18  | -55     | mA |
| $I_{CC}$ Supply current                      | $V_{CC} = \text{MAX}, \text{ See Note 2}$  |        |      | 30   |        | 43   | 30   | 50      | mA |

† For conditions shown as MIN or MAX, use the appropriate value specified under recommended operating conditions for the applicable type.

‡ All typical values are at  $V_{CC} = 5 \text{ V}, T_A = 25^\circ\text{C}$ .

§ Not more than one output should be shorted at a time.

NOTE 2:  $I_{CC}$  is measured with the inputs grounded and the outputs open.

switching characteristics,  $V_{CC} = 5 \text{ V}, T_A = 25^\circ\text{C}$

| PARAMETER¶ | FROM (INPUT) | TEST CONDITIONS  |  | MIN | TYP | MAX | UNIT |    |
|------------|--------------|------------------|--|-----|-----|-----|------|----|
|            |              | Other input low  | Other input high                                       |     |     |     |      |    |
| $t_{PLH}$  | A or B       | Other input low  | $C_L = 15 \text{ pF}, R_L = 400 \Omega,$<br>See Note 3 |     |     | 15  | 23   | ns |
| $t_{PHL}$  |              |                  |  |     |     | 11  | 17   |    |
| $t_{PLH}$  | A or B       | Other input high |  |     |     | 18  | 30   | ns |
| $t_{PHL}$  |              |                  |  |     |     | 13  | 22   |    |

¶  $t_{PLH}$  = propagation delay time, low-to-high-level output

¶  $t_{PHL}$  = propagation delay time, high-to-low-level output

NOTE 3: Load circuits and voltage waveforms are shown in Section 1.

# SN5486, SN54LS86A, SN54S86 SN7486, SN74LS86A, SN74S86 QUADRUPLE 2-INPUT EXCLUSIVE-OR GATES

SDLS124 – DECEMBER 1972 – REVISED MARCH 1988

## absolute maximum ratings over operating free-air temperature range (unless otherwise noted)

|   |                |
|---|----------------|
| Supply voltage, $V_{CC}$ (see Note 1)           | 7 V            |
| Input voltage                                   | 7 V            |
| Operating free-air temperature range: SN54LS86A | -55°C to 125°C |
| SN74LS86A                                       | 0°C to 70°C    |
| Storage temperature range                       | -65°C to 150°C |

NOTE 1: Voltage values are with respect to network ground terminal.

## recommended operating conditions

|                                       | SN54LS86A |     |      | SN74LS86A |     |      | UNIT    |
|---------------------------------------|-----------|-----|------|-----------|-----|------|---------|
|                                       | MIN       | NOM | MAX  | MIN       | NOM | MAX  |         |
| Supply voltage, $V_{CC}$              | 4.5       | 5   | 5.5  | 4.75      | 5   | 5.25 | V       |
| High-level output current, $I_{OH}$   |           |     | -400 |           |     | -400 | $\mu$ A |
| Low-level output current, $I_{OL}$    |           |     | 4    |           |     | 8    | mA      |
| Operating free-air temperature, $T_A$ | -55       |     | 125  | 0         |     | 70   | °C      |

## electrical characteristics over recommended operating free-air temperature range (unless otherwise noted)

| PARAMETER                                    | TEST CONDITIONS†  | SN54LS86A |      | SN74LS86A |      | UNIT    |      |
|--|---|-----------|------|-----------|------|---------|------|
|  |   | MIN       | TYP‡ | MAX       | MIN  |         | TYP‡ |
| $V_{IH}$ High-level input voltage            |   | 2         |      | 2         |      | V       |      |
| $V_{IL}$ Low-level input voltage             |   |           |      | 0.7       |      | 0.8     | V    |
| $V_{IK}$ Input clamp voltage                 | $V_{CC} = \text{MIN}, I_I = -18 \text{ mA}$   |           |      | -1.5      |      | -1.5    | V    |
| $V_{OH}$ High-level output voltage           | $V_{CC} = \text{MIN}, V_{IH} = 2 \text{ V}, V_{IL} = V_{IL \text{ max}}, I_{OH} = -400 \mu\text{A}$ | 2.5       | 3.4  | 2.7       | 3.4  | V       |      |
| $V_{OL}$ Low-level output voltage            | $V_{CC} = \text{MIN}, I_{OL} = 4 \text{ mA}$  | 0.25      | 0.4  | 0.25      | 0.4  | V       |      |
|  | $V_{CC} = \text{MIN}, V_{IH} = 2 \text{ V}, V_{IL} = V_{IL \text{ max}}, I_{OL} = 8 \text{ mA}$     |           |      | 0.35      | 0.5  |         |      |
| $I_I$ Input current at maximum input voltage | $V_{CC} = \text{MAX}, V_I = 7 \text{ V}$  |           | 0.2  |           | 0.2  | mA      |      |
| $I_{IH}$ High-level input current            | $V_{CC} = \text{MAX}, V_I = 2.7 \text{ V}$  |           | 40   |           | 40   | $\mu$ A |      |
| $I_{IL}$ Low-level input current             | $V_{CC} = \text{MAX}, V_I = 0.4 \text{ V}$  |           | -0.8 |           | -0.8 | mA      |      |
| $I_{OS}$ Short-circuit output current§       | $V_{CC} = \text{MAX}$   | -20       | -100 | -20       | -100 | mA      |      |
| $I_{CC}$ Supply current                      | $V_{CC} = \text{MAX},$ See Note 2   | 6.1       | 10   | 6.1       | 10   | mA      |      |

† For conditions shown as MIN or MAX, use the appropriate value specified under recommended operating conditions for the applicable type.

‡ All typical values are at  $V_{CC} = 5 \text{ V}, T_A = 25^\circ\text{C}$ .

§ Not more than one output should be shorted at a time.

NOTE 2:  $I_{CC}$  is measured with the inputs grounded and the outputs open.

## switching characteristics, $V_{CC} = 5 \text{ V}, T_A = 25^\circ\text{C}$

| PARAMETER¶ | FROM (INPUT) | TEST CONDITIONS  | MIN | TYP | MAX | UNIT |
|------------|--------------|--|-----|-----|-----|------|
|            |              |  |     |     |     |      |
| $t_{PLH}$  | A or B       | Other input low<br>$C_L = 15 \text{ pF}, R_L = 2 \text{ k}\Omega,$<br>See Note 3 |     | 12  | 23  | ns   |
| $t_{PHL}$  |              |  |     | 10  | 17  |      |
| $t_{PLH}$  | A or B       | Other input high   |     | 20  | 30  | ns   |
| $t_{PHL}$  |              |  |     | 13  | 22  |      |

¶  $t_{PLH}$  = propagation delay time, low-to-high-level output

$t_{PHL}$  = propagation delay time, high-to-low-level output

NOTE 3: Load circuits and voltage waveforms are shown in Section 1.

勝特力材料 886-3-5753170  
 勝特力电子(上海) 86-21-54151736  
 勝特力电子(深圳) 86-755-83298787  
[Http://www.100y.com.tw](http://www.100y.com.tw)



**absolute maximum ratings over operating free-air temperature range (unless otherwise noted)**

|   |                |
|---|----------------|
| Supply voltage, $V_{CC}$ (see Note 1)         | 7 V            |
| Input voltage                                 | 5.5 V          |
| Operating free-air temperature range: SN54S86 | -55°C to 125°C |
| SN74S86                                       | 0°C to 70°C    |
| Storage temperature range                     | -65°C to 150°C |

NOTE 1: Voltage values are with respect to network ground terminal.

**recommended operating conditions**

|                                       | SN54S86 |     |     | SN74S86 |     |      | UNIT |
|---------------------------------------|---------|-----|-----|---------|-----|------|------|
|                                       | MIN     | NOM | MAX | MIN     | NOM | MAX  |      |
| Supply voltage, $V_{CC}$              | 4.5     | 5   | 5.5 | 4.75    | 5   | 5.25 | V    |
| High-level output current, $I_{OH}$   |         |     | -1  |         |     | -1   | mA   |
| Low-level output current, $I_{OL}$    |         |     | 20  |         |     | 20   | mA   |
| Operating free-air temperature, $T_A$ | -55     |     | 125 | 0       |     | 70   | °C   |

**electrical characteristics over recommended operating free-air temperature range (unless otherwise noted)**

| PARAMETER                                    | TEST CONDITIONS†  | SN54S86 |      |      | SN74S86 |      |      | UNIT |
|--|---|---------|------|------|---------|------|------|------|
|  |   | MIN     | TYP‡ | MAX  | MIN     | TYP‡ | MAX  |      |
| $V_{IH}$ High-level input voltage            |   | 2       |      |      | 2       |      |      | V    |
| $V_{IL}$ Low-level input voltage             |   |         |      | 0.8  |         |      | 0.8  | V    |
| $V_{IK}$ Input clamp voltage                 | $V_{CC} = \text{MIN}, I_I = -18 \text{ mA}$   |         |      | -1.2 |         |      | -1.2 | V    |
| $V_{OH}$ High-level output voltage           | $V_{CC} = \text{MIN}, V_{IH} = 2 \text{ V}, V_{IL} = 0.8 \text{ V}, I_{OH} = -1 \text{ mA}$ | 2.5     | 3.4  |      | 2.7     | 3.4  |      | V    |
| $V_{OL}$ Low-level output voltage            | $V_{CC} = \text{MIN}, V_{IH} = 2 \text{ V}, V_{IL} = 0.8 \text{ V}, I_{OL} = 20 \text{ mA}$ |         |      | 0.5  |         |      | 0.5  | V    |
| $I_I$ Input current at maximum input voltage | $V_{CC} = \text{MAX}, V_I = 5.5 \text{ V}$  |         |      | 1    |         |      | 1    | mA   |
| $I_{IH}$ High-level input current            | $V_{CC} = \text{MAX}, V_I = 2.7 \text{ V}$  |         |      | 50   |         |      | 50   | µA   |
| $I_{IL}$ Low-level input current             | $V_{CC} = \text{MAX}, V_I = 0.5 \text{ V}$  |         |      | -2   |         |      | -2   | mA   |
| $I_{OS}$ Short-circuit output current §      | $V_{CC} = \text{MAX}$   | -40     |      | -100 | -40     |      | -100 | mA   |
| $I_{CC}$ Supply current                      | $V_{CC} = \text{MAX}, \text{ See Note 2}$   |         | 50   | 75   |         | 50   | 75   | mA   |

† For conditions shown as MIN or MAX, use the appropriate value specified under recommended operating conditions for the applicable type.

‡ All typical values are at  $V_{CC} = 5 \text{ V}, T_A = 25^\circ\text{C}$ .

§ Not more than one output should be shorted at a time, and duration of the short-circuit should not exceed one second.

NOTE 2:  $I_{CC}$  is measured with the inputs grounded and the outputs open.

**switching characteristics,  $V_{CC} = 5 \text{ V}, T_A = 25^\circ\text{C}$**

| PARAMETER¶ | FROM (INPUT) | TEST CONDITIONS  |   | MIN | TYP | MAX  | UNIT |
|------------|--------------|------------------|---|-----|-----|------|------|
|            |              | Other input low  | Other input high  |     |     |      |      |
| $t_{PLH}$  | A or B       | Other input low  | $C_L = 15 \text{ pF}, R_L = 280 \Omega, \text{ See Note 3}$ | 7   | 6.5 | 10.5 | ns   |
| $t_{PHL}$  |              |                  |   |     |     |      |      |
| $t_{PLH}$  | A or B       | Other input high | $C_L = 15 \text{ pF}, R_L = 280 \Omega, \text{ See Note 3}$ | 7   | 6.5 | 10.5 | ns   |
| $t_{PHL}$  |              |                  |   |     |     |      |      |

¶  $t_{PLH}$  = propagation delay time, low-to-high-level output

$t_{PHL}$  = propagation delay time, high-to-low-level output

NOTE 3: Load circuits and voltage waveforms are shown in Section 1.

PACKAGING INFORMATION

| Orderable Device | Status <sup>(1)</sup> | Package Type | Package Drawing | Pins | Package Qty | Eco Plan <sup>(2)</sup> | Lead/Ball Finish | MSL Peak Temp <sup>(3)</sup> |
|------------------|-----------------------|--------------|-----------------|------|-------------|-------------------------|------------------|------------------------------|
| JM38510/07501BCA | ACTIVE                | CDIP         | J               | 14   | 1           | TBD                     | A42 SNPB         | N / A for Pkg Type           |
| JM38510/07501BDA | ACTIVE                | CFP          | W               | 14   | 1           | TBD                     | A42              | N / A for Pkg Type           |
| JM38510/07501BDA | ACTIVE                | CFP          | W               | 14   | 1           | TBD                     | A42              | N / A for Pkg Type           |
| JM38510/30502B2A | ACTIVE                | LCCC         | FK              | 20   | 1           | TBD                     | POST-PLATE       | N / A for Pkg Type           |
| JM38510/30502B2A | ACTIVE                | LCCC         | FK              | 20   | 1           | TBD                     | POST-PLATE       | N / A for Pkg Type           |
| JM38510/30502BCA | ACTIVE                | CDIP         | J               | 14   | 1           | TBD                     | A42 SNPB         | N / A for Pkg Type           |
| JM38510/30502BCA | ACTIVE                | CDIP         | J               | 14   | 1           | TBD                     | A42 SNPB         | N / A for Pkg Type           |
| JM38510/30502BDA | ACTIVE                | CFP          | W               | 14   | 1           | TBD                     | A42              | N / A for Pkg Type           |
| JM38510/30502BDA | ACTIVE                | CFP          | W               | 14   | 1           | TBD                     | A42              | N / A for Pkg Type           |
| SN5486J          | ACTIVE                | CDIP         | J               | 14   | 1           | TBD                     | A42 SNPB         | N / A for Pkg Type           |
| SN5486J          | ACTIVE                | CDIP         | J               | 14   | 1           | TBD                     | A42 SNPB         | N / A for Pkg Type           |
| SN54LS86AJ       | ACTIVE                | CDIP         | J               | 14   | 1           | TBD                     | A42 SNPB         | N / A for Pkg Type           |
| SN54LS86AJ       | ACTIVE                | CDIP         | J               | 14   | 1           | TBD                     | A42 SNPB         | N / A for Pkg Type           |
| SN54S86J         | ACTIVE                | CDIP         | J               | 14   | 1           | TBD                     | A42 SNPB         | N / A for Pkg Type           |
| SN54S86J         | ACTIVE                | CDIP         | J               | 14   | 1           | TBD                     | A42 SNPB         | N / A for Pkg Type           |
| SN7486N          | OBSOLETE              | PDIP         | N               | 14   |             | TBD                     | Call TI          | Call TI                      |
| SN7486N          | OBSOLETE              | PDIP         | N               | 14   |             | TBD                     | Call TI          | Call TI                      |
| SN7486N3         | OBSOLETE              | PDIP         | N               | 14   |             | TBD                     | Call TI          | Call TI                      |
| SN7486N3         | OBSOLETE              | PDIP         | N               | 14   |             | TBD                     | Call TI          | Call TI                      |
| SN74LS86AD       | ACTIVE                | SOIC         | D               | 14   | 50          | Green (RoHS & no Sb/Br) | CU NIPDAU        | Level-1-260C-UNLIM           |
| SN74LS86AD       | ACTIVE                | SOIC         | D               | 14   | 50          | Green (RoHS & no Sb/Br) | CU NIPDAU        | Level-1-260C-UNLIM           |
| SN74LS86ADE4     | ACTIVE                | SOIC         | D               | 14   | 50          | Green (RoHS & no Sb/Br) | CU NIPDAU        | Level-1-260C-UNLIM           |
| SN74LS86ADE4     | ACTIVE                | SOIC         | D               | 14   | 50          | Green (RoHS & no Sb/Br) | CU NIPDAU        | Level-1-260C-UNLIM           |
| SN74LS86ADG4     | ACTIVE                | SOIC         | D               | 14   | 50          | Green (RoHS & no Sb/Br) | CU NIPDAU        | Level-1-260C-UNLIM           |
| SN74LS86ADG4     | ACTIVE                | SOIC         | D               | 14   | 50          | Green (RoHS & no Sb/Br) | CU NIPDAU        | Level-1-260C-UNLIM           |
| SN74LS86ADR      | ACTIVE                | SOIC         | D               | 14   | 2500        | Green (RoHS & no Sb/Br) | CU NIPDAU        | Level-1-260C-UNLIM           |
| SN74LS86ADR      | ACTIVE                | SOIC         | D               | 14   | 2500        | Green (RoHS & no Sb/Br) | CU NIPDAU        | Level-1-260C-UNLIM           |
| SN74LS86ADRE4    | ACTIVE                | SOIC         | D               | 14   | 2500        | Green (RoHS & no Sb/Br) | CU NIPDAU        | Level-1-260C-UNLIM           |
| SN74LS86ADRE4    | ACTIVE                | SOIC         | D               | 14   | 2500        | Green (RoHS & no Sb/Br) | CU NIPDAU        | Level-1-260C-UNLIM           |
| SN74LS86ADRG4    | ACTIVE                | SOIC         | D               | 14   | 2500        | Green (RoHS & no Sb/Br) | CU NIPDAU        | Level-1-260C-UNLIM           |
| SN74LS86ADRG4    | ACTIVE                | SOIC         | D               | 14   | 2500        | Green (RoHS & no Sb/Br) | CU NIPDAU        | Level-1-260C-UNLIM           |
| SN74LS86AN       | ACTIVE                | PDIP         | N               | 14   | 25          | Pb-Free (RoHS)          | CU NIPDAU        | N / A for Pkg Type           |
| SN74LS86AN       | ACTIVE                | PDIP         | N               | 14   | 25          | Pb-Free                 | CU NIPDAU        | N / A for Pkg Type           |

| Orderable Device | Status <sup>(1)</sup> | Package Type | Package Drawing | Pins | Package Qty | Eco Plan <sup>(2)</sup> | Lead/Ball Finish | MSL Peak Temp <sup>(3)</sup> |
|------------------|-----------------------|--------------|-----------------|------|-------------|-------------------------|------------------|------------------------------|
| (RoHS)           |                       |              |                 |      |             |                         |                  |                              |
| SN74LS86AN3      | OBSOLETE              | PDIP         | N               | 14   |             | TBD                     | Call TI          | Call TI                      |
| SN74LS86AN3      | OBSOLETE              | PDIP         | N               | 14   |             | TBD                     | Call TI          | Call TI                      |
| SN74LS86ANE4     | ACTIVE                | PDIP         | N               | 14   | 25          | Pb-Free (RoHS)          | CU NIPDAU        | N / A for Pkg Type           |
| SN74LS86ANE4     | ACTIVE                | PDIP         | N               | 14   | 25          | Pb-Free (RoHS)          | CU NIPDAU        | N / A for Pkg Type           |
| SN74LS86ANSR     | ACTIVE                | SO           | NS              | 14   | 2000        | Green (RoHS & no Sb/Br) | CU NIPDAU        | Level-1-260C-UNLIM           |
| SN74LS86ANSR     | ACTIVE                | SO           | NS              | 14   | 2000        | Green (RoHS & no Sb/Br) | CU NIPDAU        | Level-1-260C-UNLIM           |
| SN74LS86ANSRE4   | ACTIVE                | SO           | NS              | 14   | 2000        | Green (RoHS & no Sb/Br) | CU NIPDAU        | Level-1-260C-UNLIM           |
| SN74LS86ANSRE4   | ACTIVE                | SO           | NS              | 14   | 2000        | Green (RoHS & no Sb/Br) | CU NIPDAU        | Level-1-260C-UNLIM           |
| SN74LS86ANSRG4   | ACTIVE                | SO           | NS              | 14   | 2000        | Green (RoHS & no Sb/Br) | CU NIPDAU        | Level-1-260C-UNLIM           |
| SN74LS86ANSRG4   | ACTIVE                | SO           | NS              | 14   | 2000        | Green (RoHS & no Sb/Br) | CU NIPDAU        | Level-1-260C-UNLIM           |
| SN74S86D         | ACTIVE                | SOIC         | D               | 14   | 50          | Green (RoHS & no Sb/Br) | CU NIPDAU        | Level-1-260C-UNLIM           |
| SN74S86D         | ACTIVE                | SOIC         | D               | 14   | 50          | Green (RoHS & no Sb/Br) | CU NIPDAU        | Level-1-260C-UNLIM           |
| SN74S86DE4       | ACTIVE                | SOIC         | D               | 14   | 50          | Green (RoHS & no Sb/Br) | CU NIPDAU        | Level-1-260C-UNLIM           |
| SN74S86DE4       | ACTIVE                | SOIC         | D               | 14   | 50          | Green (RoHS & no Sb/Br) | CU NIPDAU        | Level-1-260C-UNLIM           |
| SN74S86DG4       | ACTIVE                | SOIC         | D               | 14   | 50          | Green (RoHS & no Sb/Br) | CU NIPDAU        | Level-1-260C-UNLIM           |
| SN74S86DG4       | ACTIVE                | SOIC         | D               | 14   | 50          | Green (RoHS & no Sb/Br) | CU NIPDAU        | Level-1-260C-UNLIM           |
| SN74S86DR        | ACTIVE                | SOIC         | D               | 14   | 2500        | Green (RoHS & no Sb/Br) | CU NIPDAU        | Level-1-260C-UNLIM           |
| SN74S86DR        | ACTIVE                | SOIC         | D               | 14   | 2500        | Green (RoHS & no Sb/Br) | CU NIPDAU        | Level-1-260C-UNLIM           |
| SN74S86DRE4      | ACTIVE                | SOIC         | D               | 14   | 2500        | Green (RoHS & no Sb/Br) | CU NIPDAU        | Level-1-260C-UNLIM           |
| SN74S86DRE4      | ACTIVE                | SOIC         | D               | 14   | 2500        | Green (RoHS & no Sb/Br) | CU NIPDAU        | Level-1-260C-UNLIM           |
| SN74S86DRG4      | ACTIVE                | SOIC         | D               | 14   | 2500        | Green (RoHS & no Sb/Br) | CU NIPDAU        | Level-1-260C-UNLIM           |
| SN74S86DRG4      | ACTIVE                | SOIC         | D               | 14   | 2500        | Green (RoHS & no Sb/Br) | CU NIPDAU        | Level-1-260C-UNLIM           |
| SN74S86N         | ACTIVE                | PDIP         | N               | 14   | 25          | Pb-Free (RoHS)          | CU NIPDAU        | N / A for Pkg Type           |
| SN74S86N         | ACTIVE                | PDIP         | N               | 14   | 25          | Pb-Free (RoHS)          | CU NIPDAU        | N / A for Pkg Type           |
| SN74S86N3        | OBSOLETE              | PDIP         | N               | 14   |             | TBD                     | Call TI          | Call TI                      |
| SN74S86N3        | OBSOLETE              | PDIP         | N               | 14   |             | TBD                     | Call TI          | Call TI                      |
| SN74S86NE4       | ACTIVE                | PDIP         | N               | 14   | 25          | Pb-Free (RoHS)          | CU NIPDAU        | N / A for Pkg Type           |

| Orderable Device | Status <sup>(1)</sup> | Package Type | Package Drawing | Pins | Package Qty | Eco Plan <sup>(2)</sup> | Lead/Ball Finish | MSL Peak Temp <sup>(3)</sup> |
|------------------|-----------------------|--------------|-----------------|------|-------------|-------------------------|------------------|------------------------------|
| SN74S86NE4       | ACTIVE                | PDIP         | N               | 14   | 25          | Pb-Free (RoHS)          | CU NIPDAU        | N / A for Pkg Type           |
| SN74S86NSR       | ACTIVE                | SO           | NS              | 14   | 2000        | Green (RoHS & no Sb/Br) | CU NIPDAU        | Level-1-260C-UNLIM           |
| SN74S86NSR       | ACTIVE                | SO           | NS              | 14   | 2000        | Green (RoHS & no Sb/Br) | CU NIPDAU        | Level-1-260C-UNLIM           |
| SN74S86NSRE4     | ACTIVE                | SO           | NS              | 14   | 2000        | Green (RoHS & no Sb/Br) | CU NIPDAU        | Level-1-260C-UNLIM           |
| SN74S86NSRE4     | ACTIVE                | SO           | NS              | 14   | 2000        | Green (RoHS & no Sb/Br) | CU NIPDAU        | Level-1-260C-UNLIM           |
| SN74S86NSRG4     | ACTIVE                | SO           | NS              | 14   | 2000        | Green (RoHS & no Sb/Br) | CU NIPDAU        | Level-1-260C-UNLIM           |
| SN74S86NSRG4     | ACTIVE                | SO           | NS              | 14   | 2000        | Green (RoHS & no Sb/Br) | CU NIPDAU        | Level-1-260C-UNLIM           |
| SNJ5486J         | ACTIVE                | CDIP         | J               | 14   | 1           | TBD                     | A42 SNPB         | N / A for Pkg Type           |
| SNJ5486J         | ACTIVE                | CDIP         | J               | 14   | 1           | TBD                     | A42 SNPB         | N / A for Pkg Type           |
| SNJ5486W         | ACTIVE                | CFP          | W               | 14   | 1           | TBD                     | A42              | N / A for Pkg Type           |
| SNJ5486W         | ACTIVE                | CFP          | W               | 14   | 1           | TBD                     | A42              | N / A for Pkg Type           |
| SNJ54LS86AFK     | ACTIVE                | LCCC         | FK              | 20   | 1           | TBD                     | POST-PLATE       | N / A for Pkg Type           |
| SNJ54LS86AFK     | ACTIVE                | LCCC         | FK              | 20   | 1           | TBD                     | POST-PLATE       | N / A for Pkg Type           |
| SNJ54LS86AJ      | ACTIVE                | CDIP         | J               | 14   | 1           | TBD                     | A42 SNPB         | N / A for Pkg Type           |
| SNJ54LS86AJ      | ACTIVE                | CDIP         | J               | 14   | 1           | TBD                     | A42 SNPB         | N / A for Pkg Type           |
| SNJ54LS86AW      | ACTIVE                | CFP          | W               | 14   | 1           | TBD                     | A42              | N / A for Pkg Type           |
| SNJ54LS86AW      | ACTIVE                | CFP          | W               | 14   | 1           | TBD                     | A42              | N / A for Pkg Type           |
| SNJ54S86FK       | ACTIVE                | LCCC         | FK              | 20   | 1           | TBD                     | POST-PLATE       | N / A for Pkg Type           |
| SNJ54S86FK       | ACTIVE                | LCCC         | FK              | 20   | 1           | TBD                     | POST-PLATE       | N / A for Pkg Type           |
| SNJ54S86J        | ACTIVE                | CDIP         | J               | 14   | 1           | TBD                     | A42 SNPB         | N / A for Pkg Type           |
| SNJ54S86J        | ACTIVE                | CDIP         | J               | 14   | 1           | TBD                     | A42 SNPB         | N / A for Pkg Type           |
| SNJ54S86W        | ACTIVE                | CFP          | W               | 14   | 1           | TBD                     | A42              | N / A for Pkg Type           |
| SNJ54S86W        | ACTIVE                | CFP          | W               | 14   | 1           | TBD                     | A42              | N / A for Pkg Type           |

<sup>(1)</sup> The marketing status values are defined as follows:

**ACTIVE:** Product device recommended for new designs.

**LIFEBUY:** TI has announced that the device will be discontinued, and a lifetime-buy period is in effect.

**NRND:** Not recommended for new designs. Device is in production to support existing customers, but TI does not recommend using this part in a new design.

**PREVIEW:** Device has been announced but is not in production. Samples may or may not be available.

**OBSELETE:** TI has discontinued the production of the device.

<sup>(2)</sup> Eco Plan - The planned eco-friendly classification: Pb-Free (RoHS), Pb-Free (RoHS Exempt), or Green (RoHS & no Sb/Br) - please check <http://www.ti.com/productcontent> for the latest availability information and additional product content details.

**TBD:** The Pb-Free/Green conversion plan has not been defined.

**Pb-Free (RoHS):** TI's terms "Lead-Free" or "Pb-Free" mean semiconductor products that are compatible with the current RoHS requirements for all 6 substances, including the requirement that lead not exceed 0.1% by weight in homogeneous materials. Where designed to be soldered at high temperatures, TI Pb-Free products are suitable for use in specified lead-free processes.

**Pb-Free (RoHS Exempt):** This component has a RoHS exemption for either 1) lead-based flip-chip solder bumps used between the die and package, or 2) lead-based die adhesive used between the die and leadframe. The component is otherwise considered Pb-Free (RoHS compatible) as defined above.

**Green (RoHS & no Sb/Br):** TI defines "Green" to mean Pb-Free (RoHS compatible), and free of Bromine (Br) and Antimony (Sb) based flame retardants (Br or Sb do not exceed 0.1% by weight in homogeneous material)

<sup>(3)</sup> MSL, Peak Temp. -- The Moisture Sensitivity Level rating according to the JEDEC industry standard classifications, and peak solder

temperature.

**Important Information and Disclaimer:** The information provided on this page represents TI's knowledge and belief as of the date that it is provided. TI bases its knowledge and belief on information provided by third parties, and makes no representation or warranty as to the accuracy of such information. Efforts are underway to better integrate information from third parties. TI has taken and continues to take reasonable steps to provide representative and accurate information but may not have conducted destructive testing or chemical analysis on incoming materials and chemicals. TI and TI suppliers consider certain information to be proprietary, and thus CAS numbers and other limited information may not be available for release.

In no event shall TI's liability arising out of such information exceed the total purchase price of the TI part(s) at issue in this document sold by TI to Customer on an annual basis.

勝特力材料 886-3-5753170  
勝特力电子(上海) 86-21-54151736  
勝特力电子(深圳) 86-755-83298787  
[Http://www.100y.com.tw](http://www.100y.com.tw)

**TAPE AND REEL INFORMATION**

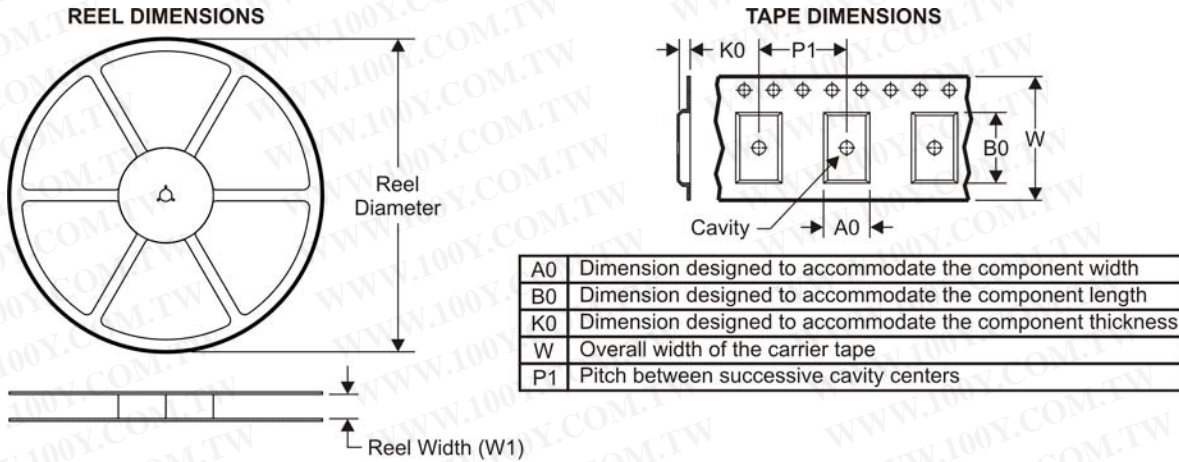

**QUADRANT ASSIGNMENTS FOR PIN 1 ORIENTATION IN TAPE**

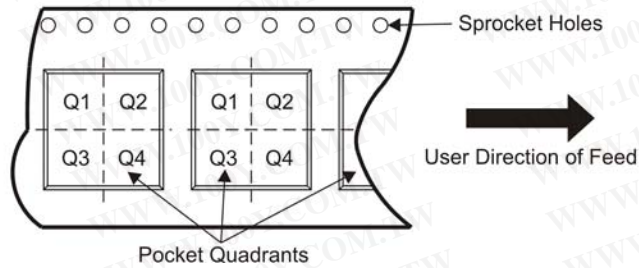

\*All dimensions are nominal

| Device       | Package Type | Package Drawing | Pins | SPQ  | Reel Diameter (mm) | Reel Width W1 (mm) | A0 (mm) | B0 (mm) | K0 (mm) | P1 (mm) | W (mm) | Pin1 Quadrant |
|--------------|--------------|-----------------|------|------|--------------------|--------------------|---------|---------|---------|---------|--------|---------------|
| SN74LS86ADR  | SOIC         | D               | 14   | 2500 | 330.0              | 16.0               | 7.0     | 9.0     | 2.0     | 8.0     | 16.0   | Q1            |
| SN74LS86ANSR | SO           | NS              | 14   | 2000 | 330.0              | 16.0               | 8.0     | 11.0    | 3.0     | 12.0    | 16.0   | Q1            |
| SN74S86DR    | SOIC         | D               | 14   | 2500 | 330.0              | 16.0               | 7.0     | 9.0     | 2.0     | 8.0     | 16.0   | Q1            |
| SN74S86NSR   | SO           | NS              | 14   | 2000 | 330.0              | 16.0               | 8.0     | 11.0    | 3.0     | 12.0    | 16.0   | Q1            |

勝特力材料 886-3-5753170  
 勝特力电子(上海) 86-21-54151736  
 勝特力电子(深圳) 86-755-83298787  
[Http://www.100y.com.tw](http://www.100y.com.tw)

**TAPE AND REEL BOX DIMENSIONS**

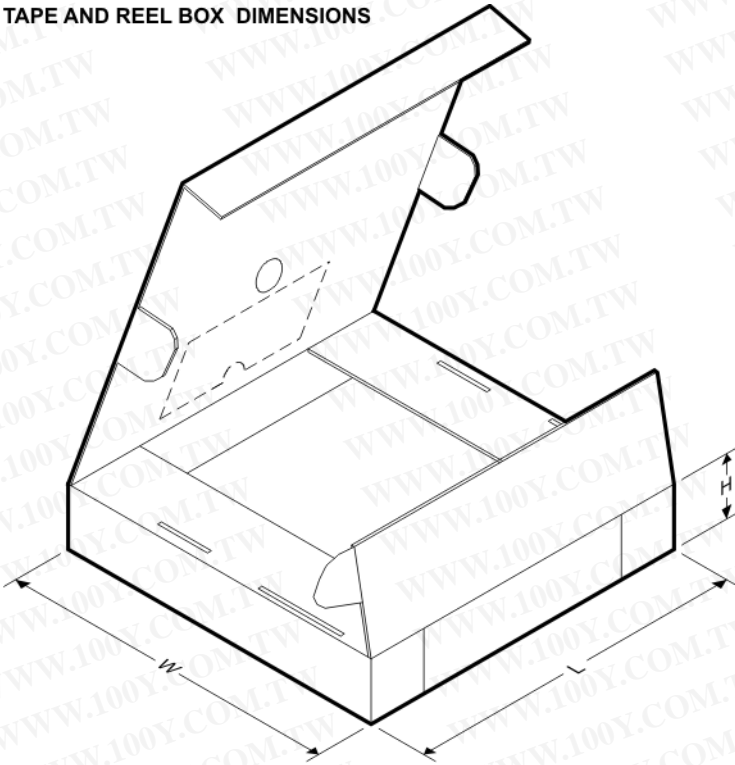

\*All dimensions are nominal

| Device       | Package Type | Package Drawing | Pins | SPQ  | Length (mm) | Width (mm) | Height (mm) |
|--------------|--------------|-----------------|------|------|-------------|------------|-------------|
| SN74LS86ADR  | SOIC         | D               | 14   | 2500 | 346.0       | 346.0      | 33.0        |
| SN74LS86ANSR | SO           | NS              | 14   | 2000 | 346.0       | 346.0      | 33.0        |
| SN74S86DR    | SOIC         | D               | 14   | 2500 | 346.0       | 346.0      | 33.0        |
| SN74S86NSR   | SO           | NS              | 14   | 2000 | 346.0       | 346.0      | 33.0        |

勝特力材料 886-3-5753170  
 勝特力电子(上海) 86-21-54151736  
 勝特力电子(深圳) 86-755-83298787  
[Http://www.100y.com.tw](http://www.100y.com.tw)

J (R-GDIP-T\*\*)  
14 LEADS SHOWN

CERAMIC DUAL IN-LINE PACKAGE

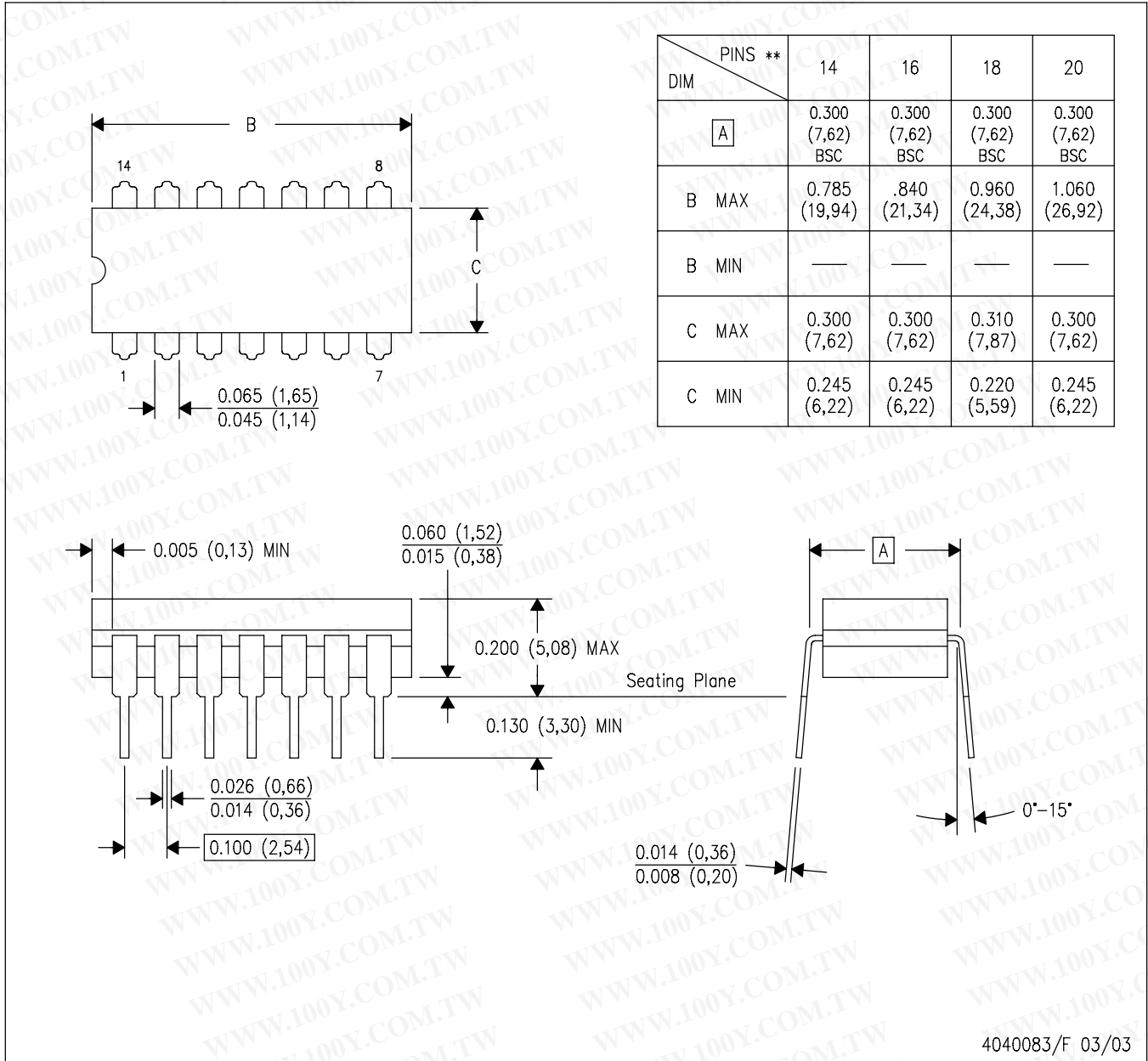

4040083/F 03/03

- NOTES:
- A. All linear dimensions are in inches (millimeters).
  - B. This drawing is subject to change without notice.
  - C. This package is hermetically sealed with a ceramic lid using glass frit.
  - D. Index point is provided on cap for terminal identification only on press ceramic glass frit seal only.
  - E. Falls within MIL STD 1835 GDIP1-T14, GDIP1-T16, GDIP1-T18 and GDIP1-T20.

**勝特力材料 886-3-5753170**  
**勝特力电子(上海) 86-21-54151736**  
**勝特力电子(深圳) 86-755-83298787**  
[Http://www.100y.com.tw](http://www.100y.com.tw)

W (R-GDFP-F14)

CERAMIC DUAL FLATPACK

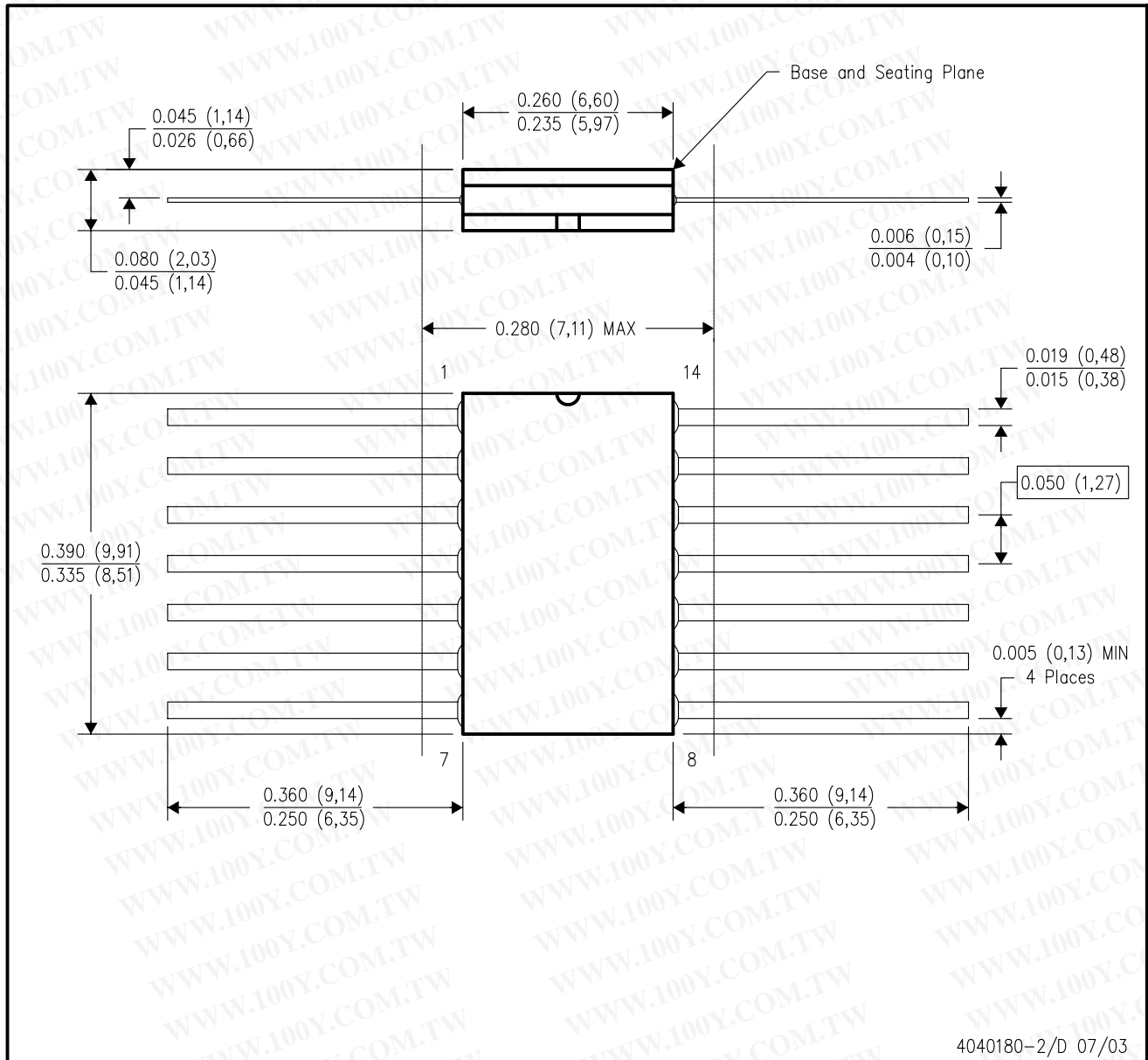

- NOTES:
- A. All linear dimensions are in inches (millimeters).
  - B. This drawing is subject to change without notice.
  - C. This package can be hermetically sealed with a ceramic lid using glass frit.
  - D. Index point is provided on cap for terminal identification only.
  - E. Falls within MIL STD 1835 GDFP1-F14 and JEDEC MO-092AB

勝特力材料 886-3-5753170  
 勝特力电子(上海) 86-21-54151736  
 勝特力电子(深圳) 86-755-83298787  
[Http://www.100y.com.tw](http://www.100y.com.tw)

FK (S-CQCC-N\*\*)

LEADLESS CERAMIC CHIP CARRIER

28 TERMINAL SHOWN

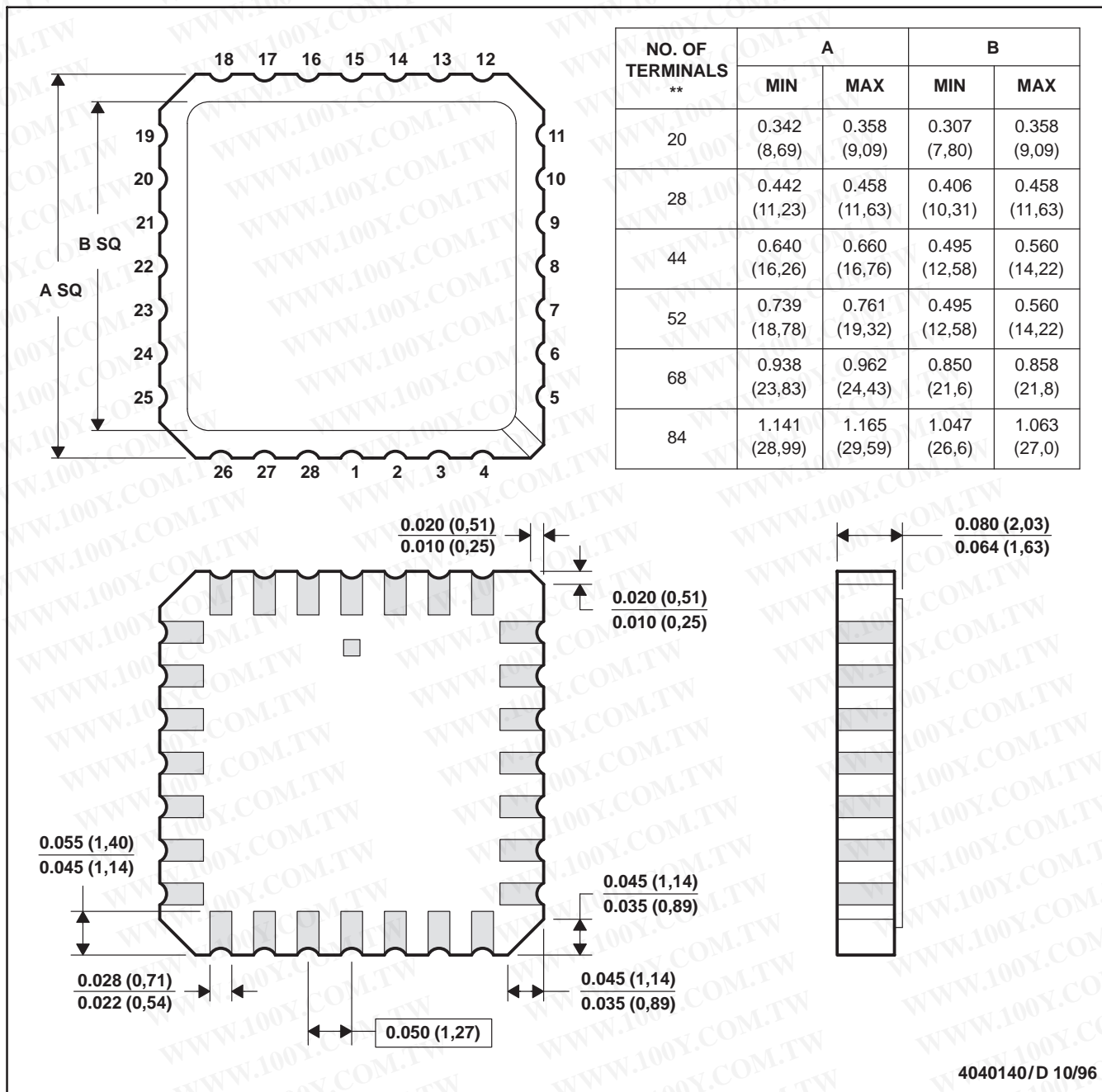

- NOTES:
- A. All linear dimensions are in inches (millimeters).
  - B. This drawing is subject to change without notice.
  - C. This package can be hermetically sealed with a metal lid.
  - D. The terminals are gold plated.
  - E. Falls within JEDEC MS-004

勝特力材料 886-3-5753170  
 勝特力电子(上海) 86-21-54151736  
 勝特力电子(深圳) 86-755-83298787  
[Http://www.100y.com.tw](http://www.100y.com.tw)

N (R-PDIP-T\*\*)

PLASTIC DUAL-IN-LINE PACKAGE

16 PINS SHOWN

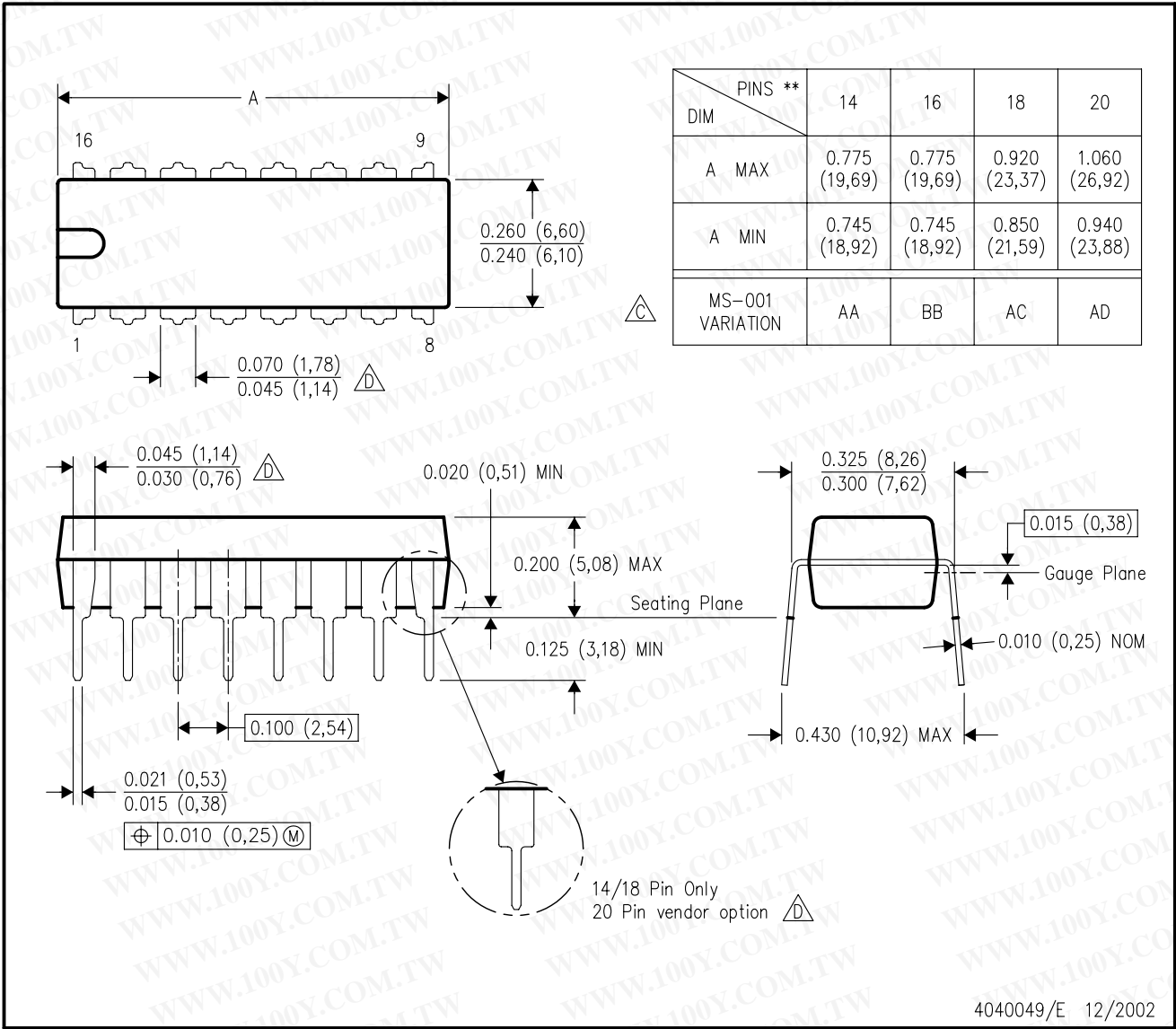

- NOTES:
- A. All linear dimensions are in inches (millimeters).
  - B. This drawing is subject to change without notice.
  - C Falls within JEDEC MS-001, except 18 and 20 pin minimum body length (Dim A).
  - D The 20 pin end lead shoulder width is a vendor option, either half or full width.



# MECHANICAL DATA

NS (R-PDSO-G\*\*)  
14-PINS SHOWN

PLASTIC SMALL-OUTLINE PACKAGE

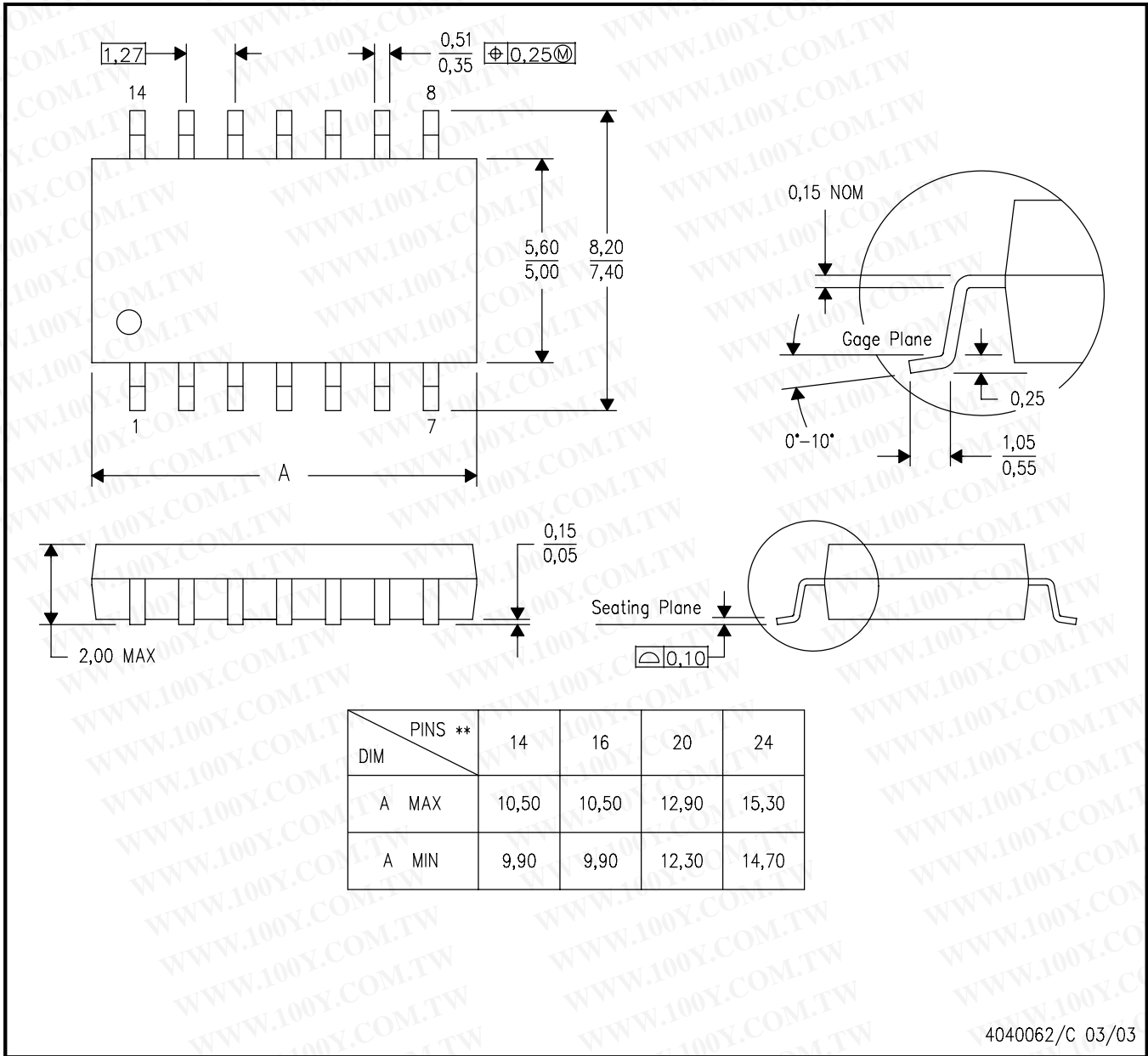

- NOTES:
- A. All linear dimensions are in millimeters.
  - B. This drawing is subject to change without notice.
  - C. Body dimensions do not include mold flash or protrusion, not to exceed 0,15.

**勝特力材料 886-3-5753170**  
**勝特力电子(上海) 86-21-54151736**  
**勝特力电子(深圳) 86-755-83298787**  
[Http://www.100y.com.tw](http://www.100y.com.tw)