

SN5474, SN54LS74A, SN54S74 SN7474, SN74LS74A, SN74S74

DUAL D-TYPE POSITIVE-EDGE-TRIGGERED FLIP-FLOPS WITH PRESET AND CLEAR

SDLS119 - DECEMBER 1983 - REVISED MARCH 1988

- Package Options Include Plastic "Small Outline" Packages, Ceramic Chip Carriers and Flat Packages, and Plastic and Ceramic DIPs
- Dependable Texas Instruments Quality and Reliability

description

These devices contain two independent D-type positive-edge-triggered flip-flops. A low level at the preset or clear inputs sets or resets the outputs regardless of the levels of the other inputs. When preset and clear are inactive (high), data at the D input meeting the setup time requirements are transferred to the outputs on the positive-going edge of the clock pulse. Clock triggering occurs at a voltage level and is not directly related to the rise time of the clock pulse. Following the hold time interval, data at the D input may be changed without affecting the levels at the outputs.

The SN54' family is characterized for operation over the full military temperature range of -55°C to 125°C . The SN74' family is characterized for operation from 0°C to 70°C .

FUNCTION TABLE

INPUTS				OUTPUTS	
PRE	CLR	CLK	D	Q	\bar{Q}
L	H	X	X	H	L
H	L	X	X	L	H
L	L	X	X	H [†]	H [†]
H	H	↑	H	H	L
H	H	↑	L	L	H
H	H	L	X	Q_0	\bar{Q}_0

[†] The output levels in this configuration are not guaranteed to meet the minimum levels in V_{OH} if the lows at preset and clear are near V_{IL} maximum. Furthermore, this configuration is nonstable; that is, it will not persist when either preset or clear returns to its inactive (high) level.

logic symbol[‡]

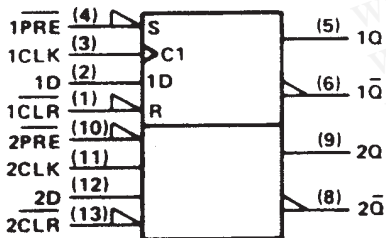

[‡]This symbol is in accordance with ANSI/IEEE Std 91-1984 and IEC Publication 617-12.

Pin numbers shown are for D, J, N, and W packages.

SN5474 . . . J PACKAGE
SN54LS74A, SN54S74 . . . J OR W PACKAGE
SN7474 . . . N PACKAGE
SN74LS74A, SN74S74 . . . D OR N PACKAGE
(TOP VIEW)

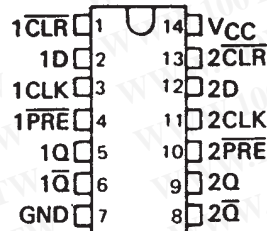

SN5474 . . . W PACKAGE
(TOP VIEW)

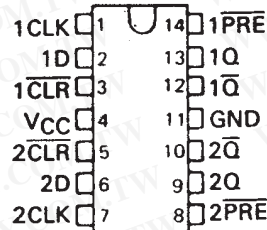

SN54LS74A, SN54S74 . . . FK PACKAGE
(TOP VIEW)

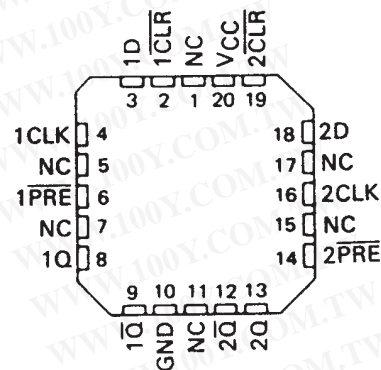

NC - No internal connection

logic diagram (positive logic)

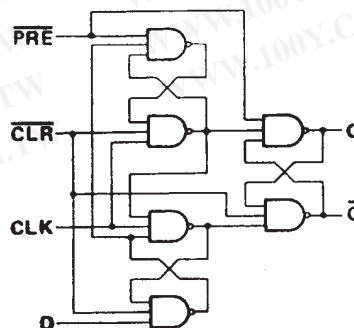

PRODUCTION DATA information is current as of publication date. Products conform to specifications per the terms of Texas Instruments standard warranty. Production processing does not necessarily include testing of all parameters.

**TEXAS
INSTRUMENTS**
 POST OFFICE BOX 655303 • DALLAS, TEXAS 75265

Copyright © 1988, Texas Instruments Incorporated

勝特力材料 886-3-5753170
 勝特力电子(上海) 86-21-54151736
 勝特力电子(深圳) 86-755-83298787
[Http://www.100y.com.tw](http://www.100y.com.tw)

SN5474, SN54LS74A, SN54S74
 SN7474, SN74LS74A, SN74S74

DUAL D-TYPE POSITIVE-EDGE-TRIGGERED FLIP-FLOPS WITH PRESET AND CLEAR

SDLS119 – DECEMBER 1983 – REVISED MARCH 1988

schematics of inputs and outputs

74

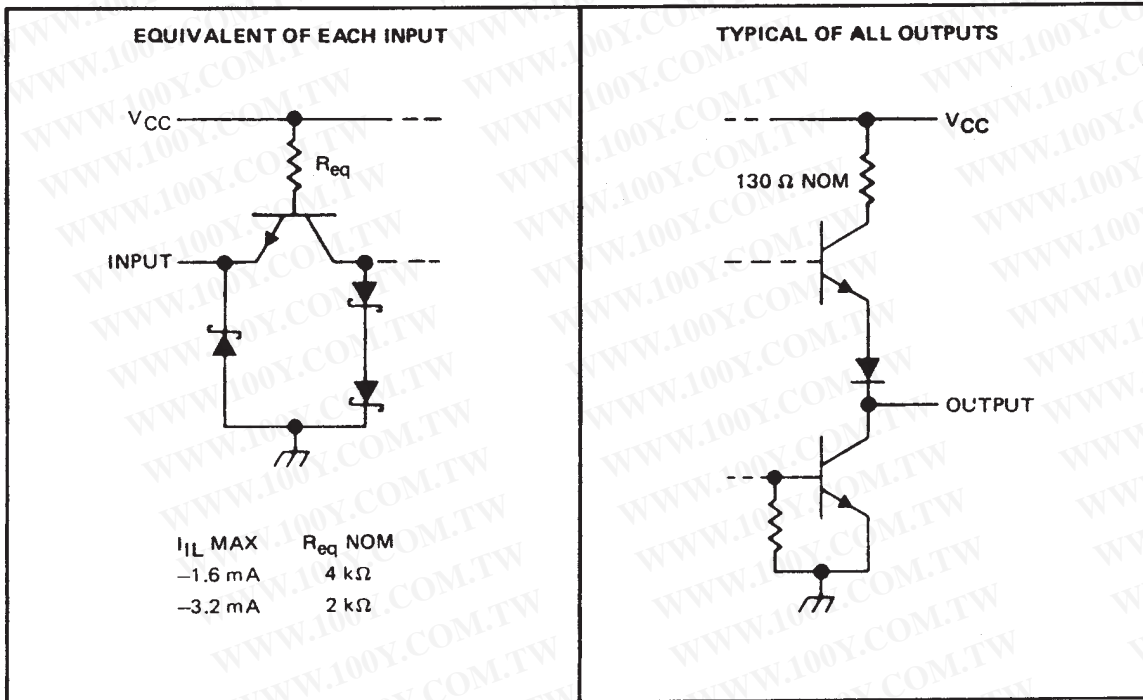

'S74

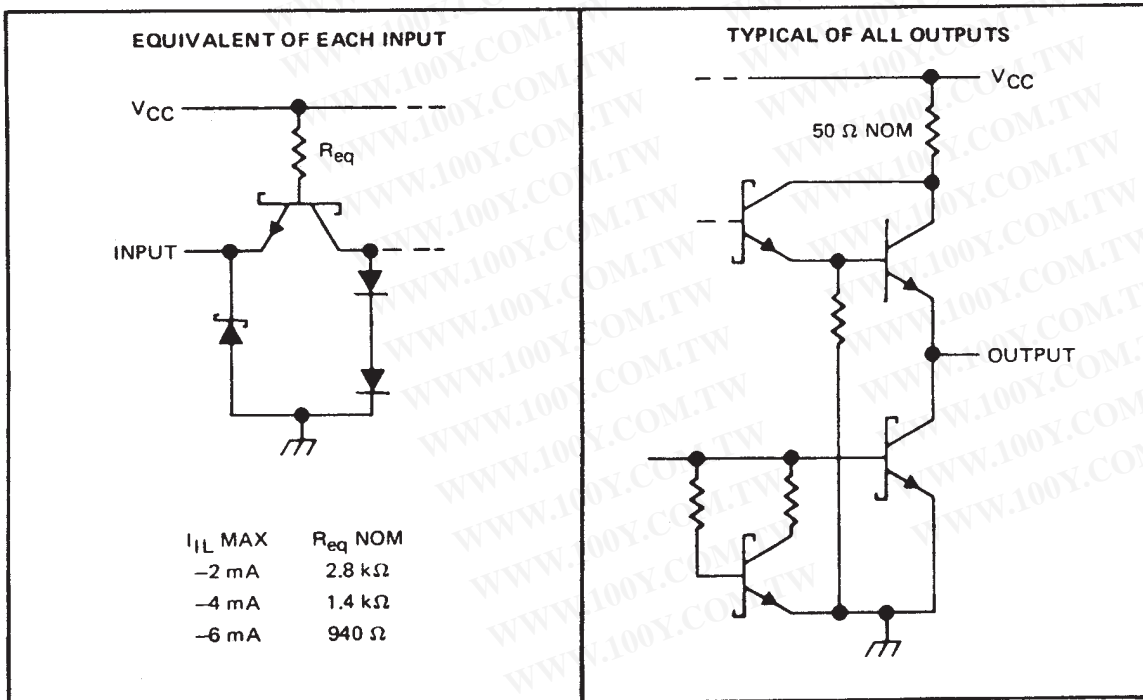

DUAL D-TYPE POSITIVE-EDGE-TRIGGERED FLIP-FLOPS WITH PRESET AND CLEAR

SDLS119 – DECEMBER 1983 – REVISED MARCH 1988

schematic

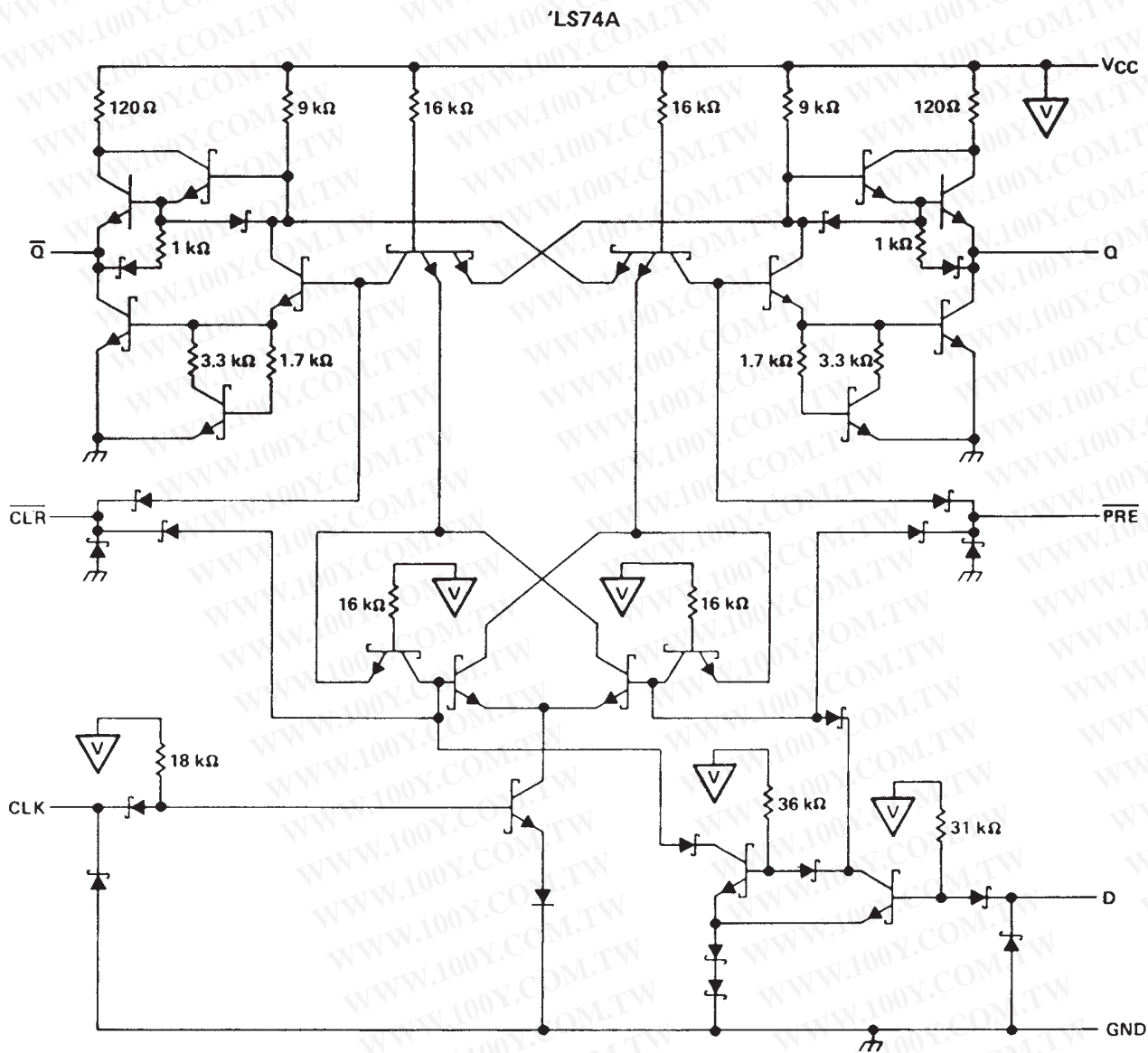

absolute maximum ratings over operating free-air temperature range (unless otherwise noted)

Supply voltage, V_{CC} (see Note 1)	7 V
Input voltage: '74, 'S74	5.5 V
'LS74A	7 V
Operating free-air temperature range: SN54'	-55°C to 125°C
SN74'	0°C to 70°C
Storage temperature range	-65°C to 150°C

NOTE 1: Voltage values are with respect to network ground terminal.

勝特力材料 886-3-5753170
 勝特力电子(上海) 86-21-54151736
 勝特力电子(深圳) 86-755-83298787
[Http://www.100y.com.tw](http://www.100y.com.tw)



SN5474, SN54LS74A, SN54S74
SN7474, SN74LS74A, SN74S74

DUAL D-TYPE POSITIVE-EDGE-TRIGGERED FLIP-FLOPS WITH PRESET AND CLEAR

SDLS119 – DECEMBER 1983 – REVISED MARCH 1988

recommended operating conditions

		SN5474			SN7474			UNIT
		MIN	NOM	MAX	MIN	NOM	MAX	
V _{CC}	Supply voltage	4.5	5	5.5	4.75	5	5.25	V
V _{IH}	High-level input voltage	2			2			V
V _{IL}	Low-level input voltage			0.8			0.8	V
I _{OH}	High-level output current			-0.4			-0.4	mA
I _{OL}	Low-level output current			16			16	mA
t _w	Pulse duration	CLK high		30	30		ns	
		CLK low		37	37			
		PRE or CLR low		30	30			
t _{su}	Input setup time before CLK ↑	20			20			ns
t _h	Input hold time-data after CLK ↑	5			5			ns
T _A	Operating free-air temperature	-55		125	0		70	°C

electrical characteristics over recommended operating free-air temperature range (unless otherwise noted)

PARAMETER		TEST CONDITIONS†		SN5474		SN7474		UNIT	
				MIN	TYP‡	MAX	MIN		TYP‡
V _{IK}		V _{CC} = MIN,	I _I = -12 mA			-1.5	-1.5	V	
V _{OH}		V _{CC} = MIN,	V _{IH} = 2 V, V _{IL} = 0.8 V, I _{OH} = -0.4 mA	2.4	3.4	2.4	3.4	V	
V _{OL}		V _{CC} = MIN,	V _{IH} = 2 V, V _{IL} = 0.8 V, I _{OL} = 16 mA	0.2	0.4	0.2	0.4	V	
I _I		V _{CC} = MAX,	V _I = 5.5 V			1	1	mA	
I _{IH}	D	V _{CC} = MAX,	V _I = 2.4 V			40	40	μA	
	CLR					120	120		
	All Other					80	80		
I _{IL}	D	V _{CC} = MAX,	V _I = 0.4 V			-1.6	-1.6	mA	
	PRE‡					-1.6	-1.6		
	CLR‡					-3.2	-3.2		
	CLK					-3.2	-3.2		
I _{OS} †		V _{CC} = MAX		-20		-57	-18	-57	mA
I _{CC} #		V _{CC} = MAX,	See Note 2		8.5	15	8.5	15	mA

†For conditions shown as MIN or MAX, use the appropriate value specified under recommended operating conditions.

‡All typical values are at V_{CC} = 5 V, T_A = 25°C.

§Clear is tested with preset high and preset is tested with clear high.

†Not more than one output should be shown at a time.

#Average per flip-flop.

NOTE 2: With all outputs open, I_{CC} is measured with the Q and Q̄ outputs high in turn. At the time of measurement, the clock input is grounded.

switching characteristics, V_{CC} = 5 V, T_A = 25°C (see note 3)

PARAMETER	FROM (INPUT)	TO (OUTPUT)	TEST CONDITIONS	MIN	TYP	MAX	UNIT
f _{max}			R _L = 400 Ω, C _L = 15 pF	15	25		MHz
t _{PLH}	PRE or CLR	Q or Q̄				25	ns
t _{PHL}						40	ns
t _{PLH}				CLK	Q or Q̄		14
t _{PHL}		20				40	ns

NOTE 3: Load circuits and voltage waveforms are shown in Section 1.



POST OFFICE BOX 655303 • DALLAS, TEXAS 75265

勝特力材料 886-3-5753170
 勝特力电子(上海) 86-21-54151736
 勝特力电子(深圳) 86-755-83298787
[Http://www.100y.com.tw](http://www.100y.com.tw)

DUAL D-TYPE POSITIVE-EDGE-TRIGGERED FLIP-FLOPS WITH PRESET AND CLEAR

SDLS119 – DECEMBER 1983 – REVISED MARCH 1988

recommended operating conditions

		SN54LS74A			SN74LS74A			UNIT	
		MIN	NOM	MAX	MIN	NOM	MAX		
V _{CC}	Supply voltage	4.5	5	5.5	4.75	5	5.25	V	
V _{IH}	High-level input voltage	2			2			V	
V _{IL}	Low-level input voltage			0.7			0.8	V	
I _{OH}	High-level output current			-0.4			-0.4	mA	
I _{OL}	Low-level output current			4			8	mA	
f _{clock}	Clock frequency	0		25	0		25	MHz	
t _w	Pulse duration	CLK high		25	25			ns	
		PRE or CLR low		25	25				
t _{su}	Setup time-before CLK ↑	High-level data		20	20			ns	
		Low-level data		20	20				
t _h	Hold time-data after CLK ↑			5	5			ns	
T _A	Operating free-air temperature			-55	125		0	70	°C

electrical characteristics over recommended operating free-air temperature range (unless otherwise noted)

PARAMETER		TEST CONDITIONS†	SN54LS74A			SN74LS74A			UNIT
			MIN	TYP‡	MAX	MIN	TYP‡	MAX	
V _{IK}		V _{CC} = MIN, I _I = -18 mA			-1.5			-1.5	V
V _{OH}		V _{CC} = MIN, I _{OH} = -0.4 mA, V _{IH} = 2 V, V _{IL} = MAX,	2.5	3.4		2.7	3.4		V
V _{OL}		V _{CC} = MIN, I _{OL} = 4 mA, V _{IL} = MAX, V _{IH} = 2 V,	0.25	0.4		0.25	0.4		V
		V _{CC} = MIN, I _{OL} = 8 mA, V _{IL} = MAX, V _{IH} = 2 V,				0.35	0.5		
I _I	D or CLK	V _{CC} = MAX, V _I = 7 V			0.1			0.1	mA
	CLR or PRE				0.2			0.2	
I _{IH}	D or CLK	V _{CC} = MAX, V _I = 2.7 V			20			20	μA
	CLR or PRE				40			40	
I _{IL}	D or CLK	V _{CC} = MAX, V _I = 0.4 V			-0.4			-0.4	mA
	CLR or PRE				-0.8			-0.8	
I _{OS} §		V _{CC} = MAX, See Note 4	-20	-100		-20	-100		mA
I _{CC} (Total)		V _{CC} = MAX, See Note 2	4 8			4 8			mA

† For conditions shown as MIN or MAX, use the appropriate value specified under recommended operating conditions.

‡ All typical values are at V_{CC} = 5 V, T_A = 25°C.

§ Not more than one output should be shorted at a time, and the duration of the short circuit should not exceed one second.

NOTE 2: With all outputs open, I_{CC} is measured with the Q and Q̄ outputs high in turn. At the time of measurement, the clock input is grounded.

NOTE 4: For certain devices where state commutation can be caused by shorting an output to ground, an equivalent test may be performed with V_O = 2.25 V and 2.125 V for the 54 family and the 74 family, respectively, with the minimum and maximum limits reduced to one half of their stated values.

switching characteristics, V_{CC} = 5 V, T_A = 25°C (see note 3)

PARAMETER	FROM (INPUT)	TO (OUTPUT)	TEST CONDITIONS		MIN	TYP	MAX	UNIT
f _{max}					25	33		MHz
t _{PLH}	CLR, PRE or CLK	Q or Q̄	R _L = 2 kΩ,	C _L = 15 pF		13	25	ns
t _{PHL}						25	40	ns

Note 3: Load circuits and voltage waveforms are shown in Section 1.

勝特力材料 886-3-5753170
勝特力电子(上海) 86-21-54151736
勝特力电子(深圳) 86-755-83298787
Http://www.100y.com.tw



SN5474, SN54LS74A, SN54S74
SN7474, SN74LS74A, SN74S74

DUAL D-TYPE POSITIVE-EDGE-TRIGGERED FLIP-FLOPS WITH PRESET AND CLEAR

SDLS119 – DECEMBER 1983 – REVISED MARCH 1988

recommended operating conditions

		SN54S74			SN74S74			UNIT
		MIN	NOM	MAX	MIN	NOM	MAX	
V _{CC}	Supply voltage	4.5	5	5.5	4.75	5	5.25	V
V _{IH}	High-level input voltage	2			2			V
V _{IL}	Low-level input voltage	0.8			0.8			V
I _{OH}	High-level output current	-1			-1			mA
I _{OL}	Low-level output current	20			20			mA
t _w	Pulse duration	CLK high	6		6		ns	
		CLK low	7.3		7.3			
		CLR or PRE low	7		7			
t _{su}	Setup time, before CLK ↑	High-level data	3		3		ns	
		Low-level data	3		3			
t _h	Input hold time - data after CLK ↑	2			2			ns
T _A	Operating free-air temperature	-55	125		0	70		°C

electrical characteristics over recommended operating free-air temperature range (unless otherwise noted)

PARAMETER		TEST CONDITIONS†	SN54S74			SN74S74			UNIT
			MIN	TYP‡	MAX	MIN	TYP‡	MAX	
V _{IK}		V _{CC} = MIN, I _I = -18 mA,	-1.2			-1.2			V
V _{OH}		V _{CC} = MIN, V _{IH} = 2 V, V _{IL} = 0.8 V, I _{OH} = -1 mA	2.5	3.4		2.7	3.4		V
V _{OL}		V _{CC} = MIN, V _{IH} = 2 V, V _{IL} = 0.8 V, I _{OL} = 20 mA	0.5			0.5			V
I _I		V _{CC} = MAX, V _I = 5.5 V	1			1			mA
I _{IH}	D	V _{CC} = MAX, V _I = 2.7 V	50			50			μA
	CLR		150			150			
	PRE or CLK		100			100			
I _{IL}	D	V _{CC} = MAX, V _I = 0.5 V	-2			-2			mA
	CLR†		-6			-6			
	PRE†		-4			-4			
	CLK		-4			-4			
I _{OS} ‡		V _{CC} = MAX	-40	-100		-40	-100	mA	
I _{CC} #		V _{CC} = MAX, See Note 2	15	25		15	25	mA	

†For conditions shown as MIN or MAX, use the appropriate value specified under recommended operating conditions.

‡All typical values are at V_{CC} = 5 V, T_A = 25°C.

§Not more than one output should be shorted at a time, and the duration of the short circuit should not exceed one second.

¶Clear is tested with preset high and preset is tested with clear high.

#Average per flip-flop.

NOTE 2: With all outputs open, I_{CC} is measured with the Q and Q̄ outputs high in turn. At the time of measurement, the clock input is grounded.

switching characteristics, V_{CC} = 5 V, T_A = 25°C (see note 3)

PARAMETER	FROM (INPUT)	TO (OUTPUT)	TEST CONDITIONS	MIN	TYP	MAX	UNIT
f _{max}				75	110		MHz
t _{PLH}	PRE or CLR	Q or Q̄	R _L = 280 Ω, C _L = 15 pF		4	6	ns
t _{PHL}	PRE or CLR (CLK high)	Q̄ or Q		9	13.5		ns
	PRE or CLR (CLK low)			5	8		ns
t _{PLH}	CLK	Q or Q̄		6	9		ns
t _{PHL}				6	9		ns

NOTE 3: Load circuits and voltage waveforms are shown in Section 1.



POST OFFICE BOX 655303 • DALLAS, TEXAS 75265

勝特力材料 886-3-5753170
勝特力电子(上海) 86-21-54151736
勝特力电子(深圳) 86-755-83298787
[Http://www.100y.com.tw](http://www.100y.com.tw)