

SN54AC04, SN74AC04 HEX INVERTERS

SCAS519C – JULY 1995 – REVISED SEPTEMBER 1996

- **EPIC™ (Enhanced-Performance Implanted CMOS) 1-μm Process**
- **Package Options Include Plastic Small-Outline (D), Shrink Small-Outline (DB), and Thin Shrink Small-Outline (PW) Packages, Ceramic Chip Carriers (FK) and Flatpacks (W), and Standard Plastic (N) and Ceramic (J) DIPs**

description

The 'AC04 contain six independent inverters. The devices perform the Boolean function $Y = \bar{A}$.

The SN54AC04 is characterized for operation over the full military temperature range of -55°C to 125°C . The SN74AC04 is characterized for operation from -40°C to 85°C .

FUNCTION TABLE
(each inverter)

INPUT A	OUTPUT Y
H	L
L	H

SN54AC04 . . . J OR W PACKAGE
SN74AC04 . . . D, DB, N, OR PW PACKAGE
(TOP VIEW)

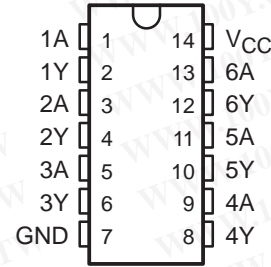

SN54AC04 . . . FK PACKAGE
(TOP VIEW)

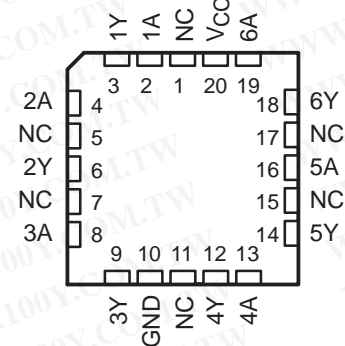

NC – No internal connection

logic symbol†

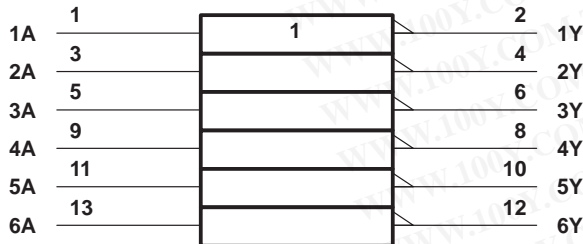

logic diagram, each inverter (positive logic)



勝特力材料 886-3-5753170
勝特力电子(上海) 86-21-54151736
勝特力电子(深圳) 86-755-83298787
[Http://www.100y.com.tw](http://www.100y.com.tw)

† This symbol is in accordance with ANSI/IEEE Std 91-1984 and IEC Publication 617-12.

Pin numbers shown are for the D, DB, J, N, PW, and W packages.



Please be aware that an important notice concerning availability, standard warranty, and use in critical applications of Texas Instruments semiconductor products and disclaimers thereto appears at the end of this data sheet.

EPIC is a trademark of Texas Instruments Incorporated.

PRODUCTION DATA information is current as of publication date. Products conform to specifications per the terms of Texas Instruments standard warranty. Production processing does not necessarily include testing of all parameters.

**TEXAS
INSTRUMENTS**

Copyright © 1996, Texas Instruments Incorporated

SN54AC04, SN74AC04 HEX INVERTERS

SCAS519C – JULY 1995 – REVISED SEPTEMBER 1996

勝特力材料 886-3-5753170
 勝特力电子(上海) 86-21-54151736
 勝特力电子(深圳) 86-755-83298787
[Http://www.100y.com.tw](http://www.100y.com.tw)

absolute maximum ratings over operating free-air temperature range (unless otherwise noted)†

Supply voltage range, V_{CC}	-0.5 V to 7 V
Input voltage range, V_I (see Note 1)	-0.5 V to $V_{CC} + 0.5$ V
Output voltage range, V_O (see Note 1)	-0.5 V to $V_{CC} + 0.5$ V
Input clamp current, I_{IK} ($V_I < 0$ or $V_I > V_{CC}$)	± 20 mA
Output clamp current, I_{OK} ($V_O < 0$ or $V_O > V_{CC}$)	± 20 mA
Continuous output current, I_O ($V_O = 0$ to V_{CC})	± 50 mA
Continuous current through V_{CC} or GND	± 200 mA
Maximum power dissipation at $T_A = 55^\circ\text{C}$ (in still air) (see Note 2):	
D package	1.25 W
DB package	0.5 W
N package	1.1 W
PW package	0.5 W
Storage temperature range, T_{stg}	-65°C to 150°C

† Stresses beyond those listed under “absolute maximum ratings” may cause permanent damage to the device. These are stress ratings only, and functional operation of the device at these or any other conditions beyond those indicated under “recommended operating conditions” is not implied. Exposure to absolute-maximum-rated conditions for extended periods may affect device reliability.

- NOTES: 1. The input and output voltage ratings may be exceeded if the input and output current ratings are observed.
 2. The maximum package power dissipation is calculated using a junction temperature of 150°C and a board trace length of 750 mils, except for the N package, which has a trace length of zero.

recommended operating conditions (see Note 3)

		SN54AC04		SN74AC04		UNIT
		MIN	MAX	MIN	MAX	
V_{CC}	Supply voltage	2	6	2	6	V
V_{IH}	High-level input voltage	$V_{CC} = 3$ V		2.1		V
		$V_{CC} = 4.5$ V		3.15		
		$V_{CC} = 5.5$ V		3.85		
V_{IL}	Low-level input voltage	$V_{CC} = 3$ V		0.9		V
		$V_{CC} = 4.5$ V		1.35		
		$V_{CC} = 5.5$ V		1.65		
V_I	Input voltage	0	V_{CC}	0	V_{CC}	V
V_O	Output voltage	0	V_{CC}	0	V_{CC}	V
I_{OH}	High-level output current	$V_{CC} = 3$ V		-12		mA
		$V_{CC} = 4.5$ V		-24		
		$V_{CC} = 5.5$ V		-24		
I_{OL}	Low-level output current	$V_{CC} = 3$ V		12		mA
		$V_{CC} = 4.5$ V		24		
		$V_{CC} = 5.5$ V		24		
$\Delta t/\Delta v$	Input transition rise or fall rate	0	8	0	8	ns/V
T_A	Operating free-air temperature	-55	125	-40	85	$^\circ\text{C}$

NOTE 3: Unused inputs must be held high or low to prevent them from floating.

electrical characteristics over recommended operating free-air temperature range (unless otherwise noted)

PARAMETER	TEST CONDITIONS	V _{CC}	T _A = 25°C			SN54AC04		SN74AC04		UNIT
			MIN	TYP	MAX	MIN	MAX	MIN	MAX	
V _{OH}	I _{OH} = -50 μA	3 V	2.9	2.99		2.9		2.9	V	
		4.5 V	4.4	4.49		4.4		4.4		
		5.5 V	5.4	5.49		5.4		5.4		
	I _{OH} = -12 mA	3 V	2.56			2.4		2.46		
		4.5 V	3.86			3.7		3.76		
	I _{OH} = -24 mA	5.5 V	4.86			4.7		4.76		
		I _{OH} = -50 mA†	5.5 V			3.85				
I _{OH} = -75 mA†	5.5 V						3.85			
V _{OL}	I _{OH} = 50 μA	3 V		0.002	0.1		0.1		0.1	
		4.5 V		0.001	0.1		0.1		0.1	
		5.5 V		0.001	0.1		0.1		0.1	
	I _{OL} = 12 mA	3 V			0.36		0.5		0.44	
		4.5 V			0.36		0.5		0.44	
	I _{OL} = 24 mA	5.5 V			0.36		0.5		0.44	
		I _{OL} = 50 mA†	5.5 V				1.65			
I _{OL} = 75 mA†	5.5 V						1.65			
I _I	V _I = V _{CC} or GND	5.5 V			±0.1		±1		±1	μA
I _{CC}	V _I = V _{CC} or GND, I _O = 0	5.5 V			2		40		20	μA
C _i	V _I = V _{CC} or GND				2.8					pF

† Not more than one output should be tested at a time, and the duration of the test should not exceed 2 ms.

switching characteristics over recommended operating free-air temperature range, V_{CC} = 3.3 V ± 0.3 V (unless otherwise noted) (see Figure 1)

PARAMETER	FROM (INPUT)	TO (OUTPUT)	T _A = 25°C			SN54AC04		SN74AC04		UNIT
			MIN	TYP	MAX	MIN	MAX	MIN	MAX	
t _{PLH}	A	Y	1.5	4.5	9	1	11	1	10	ns
t _{PHL}			1.5	4.5	8.5	1	10	1	9.5	

switching characteristics over recommended operating free-air temperature range, V_{CC} = 5 V ± 0.5 V (unless otherwise noted) (see Figure 1)

PARAMETER	FROM (INPUT)	TO (OUTPUT)	T _A = 25°C			SN54AC04		SN74AC04		UNIT
			MIN	TYP	MAX	MIN	MAX	MIN	MAX	
t _{PLH}	A	Y	1.5	4	7	1	8.5	1	7.5	ns
t _{PHL}			1.5	3.5	6.5	1	7.5	1	7	

operating characteristics, V_{CC} = 5 V, T_A = 25°C

PARAMETER	TEST CONDITIONS	TYP	UNIT
C _{pd} Power dissipation capacitance	C _L = 50 pF, f = 1 MHz	45	pF

SN54AC04, SN74AC04 HEX INVERTERS

SCAS519C – JULY 1995 – REVISED SEPTEMBER 1996

PARAMETER MEASUREMENT INFORMATION

TEST	S1
t_{PLH}/t_{PHL}	Open

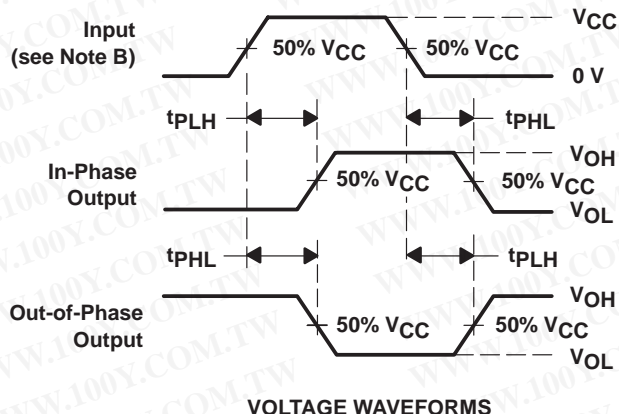
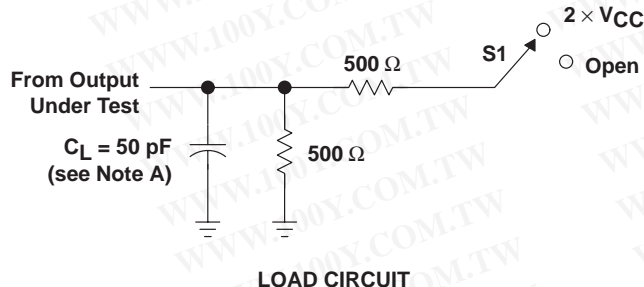

- NOTES: A. C_L includes probe and jig capacitance.
 B. All input pulses are supplied by generators having the following characteristics: $PRR \leq 1 \text{ MHz}$, $Z_O = 50 \Omega$, $t_r \leq 2.5 \text{ ns}$, $t_f \leq 2.5 \text{ ns}$.
 C. The outputs are measured one at a time with one input transition per measurement.

Figure 1. Load Circuit and Voltage Waveforms

勝特力材料 886-3-5753170
 勝特力电子(上海) 86-21-54151736
 勝特力电子(深圳) 86-755-83298787
[Http://www.100y.com.tw](http://www.100y.com.tw)