

Pitch 5.00mm Poles 2P.3P

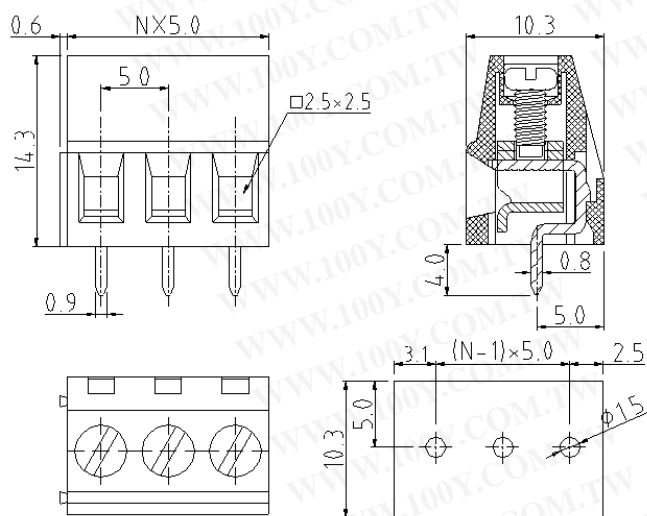
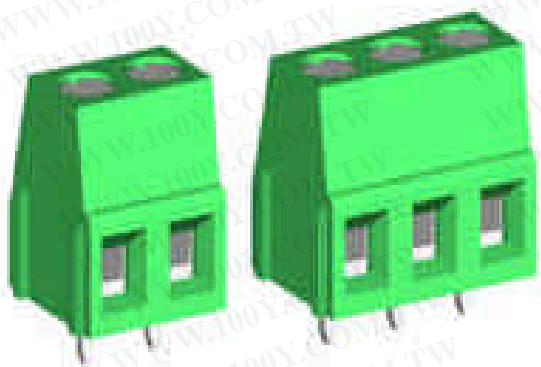

Electrical:

Electrical:	UL	VDE
Voltage rating:	300V	300V
Current rating:	10A	10A
Wire range:		2.5mm ²
Solid wire(AWG):	12-22	
Stranded wire(AWG):	12-22	
Torque (kgf.cm):	4	
Screw:	M2.5	
Wire strip length:	6~7mm	
Withstanding Voltage:	2KV	
Operating temperature:	-30 °C to +105 °C	
Soldering temperature:	245 °C ±10 °C/5Sec	

Materials

Material:	
Terminal Body (metal housing):	Brass(CuZn)
Terminal screw:	Steel
Contacts:	Brass
Surface of solder tail:	Tin plated
Insulator (housing):	Thermoplastic(UL94V-0)

How to Order



End Stackable 02 2contacts (basic block) 03 3 contacts (basic block) 30 30 contactS (pitch 5.0/7.5 mm 15 15 contactS (pitch 10.0/15.0 mm)	0 5.00/.197" 1 10.00/.394"	0 "-" /+"Combination type W/Brass Machined Clamp 1 "- Slot type W/Brass Machined Clamp 4 "-" /+"Combination type W/Steel Stamping Clamp 5 "- Slot type W/Steel Stamping Clamp	0 Black 6 Blue 8 Grey 5 Green C 6018/T(RAL)	0 3.8mm 1 4.0mm
--	-------------------------------	---	---	-----------------



勝特力材料 886-3-5753170
 勝特力电子(上海) 86-21-54151736
 勝特力电子(深圳) 86-755-83298787
[Http://www.100y.com.tw](http://www.100y.com.tw)