

Part Number	Description
SD24R50-06	12-280 Vac
SD24R50	12-280 Vac
SD24D50-06	12-280 Vac
SD48D40-06	24-500 Vac
SD48D50A	24-600 Vac
SD48D50A2	24-600 Vac

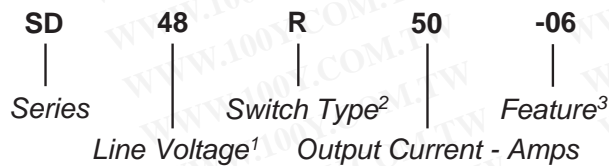

Part Number Explanation



NOTES

- 1) Line Voltage (nominal): 24 = 240 Vac; 48 = 480 Vac
- 2) Switch Type: R = Random turn-on; D = Zero-cross turn-on;
- 3) Features: -06 = Faston terminals
 A = Common control adapter
 A2 = Individual control adapter

INPUT (CONTROL) SPECIFICATION

	Min	Max	Units
Control Range			
SD24	4	30	Vdc
SD48D40-06	5	30	Vdc
SD48D50XX	10	30	Vdc
Input Current Range			
All relays (See Fig. 3)	3		mA
Must Turn-Off Voltage			
All relays		1	Vdc
Input Resistance (Typical)			
SD24R50-06		1000	Ohms
SD48D40-06		1000	Ohms
SD48D50A		1400	Ohms
SD48D50A2		1800	Ohms
Reverse Voltage Protection			
All relays		30	V

FEATURES/BENEFITS

- Designed for all types of loads
- Dual output (two relays in one package)
- Faston terminals
- Connector for common or individual control
- Tight zero-cross window for low EMI
- High immunity to surges

DESCRIPTION

The Series SD dual-phase relays are designed for all types of loads. The design incorporates two relays in a single package. The relays utilize optical isolation to protect the control from load transients. High-current models are excellent for motor and phase angle control. The 50A 600 Vac models are available with common control connector or individual control connector.

APPLICATIONS

- Motor control
- Heating control
- Uninterruptible power supplies
- Light dimmers
- Industrial and process control
- On/Off controls of AC equipment

APPROVALS

All models are UL recognized.
 UL File Number: E128555.

BLOCK DIAGRAM

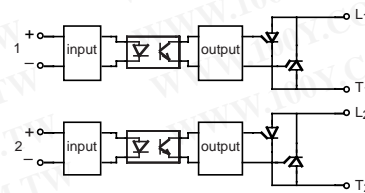

Figure 1a — All SD relays except SD48D40-06

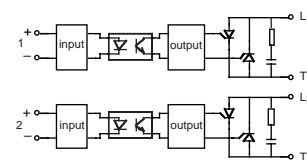

Figure 1b — SD48D40-06

勝特力材料 886-3-5753170
 勝特力电子(上海) 86-21-54151736
 勝特力电子(深圳) 86-755-83298787
 Http://www.100y.com.tw

MECHANICAL SPECIFICATION

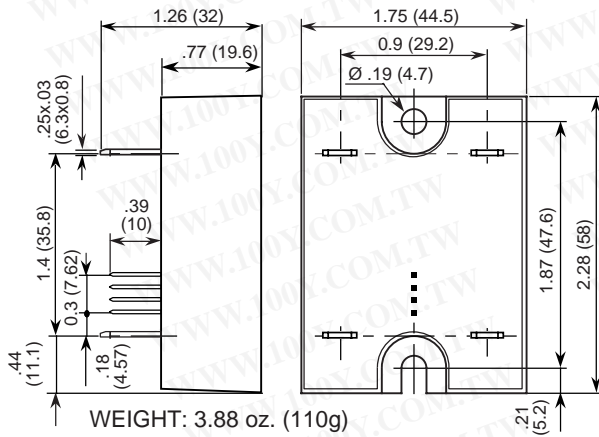

Figure 2a — SD24R50-06 and SD24D50-06; dimensions in inches (mm)

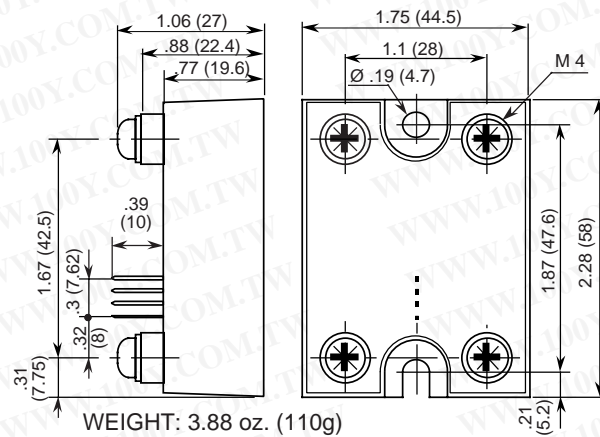

Figure 2b — SD24R50; dimensions in inches (mm)

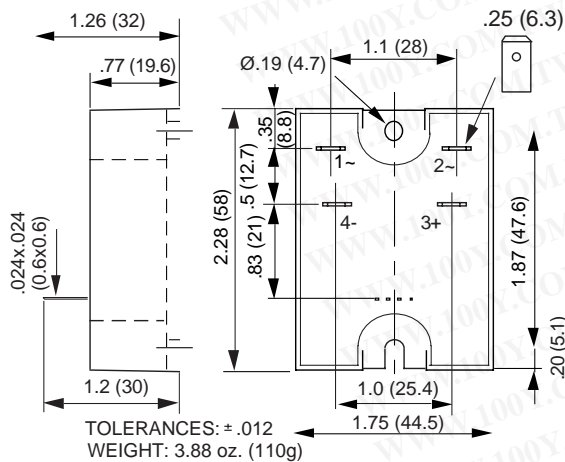

Figure 2c — SD48D40-06; dimensions in inches (mm)

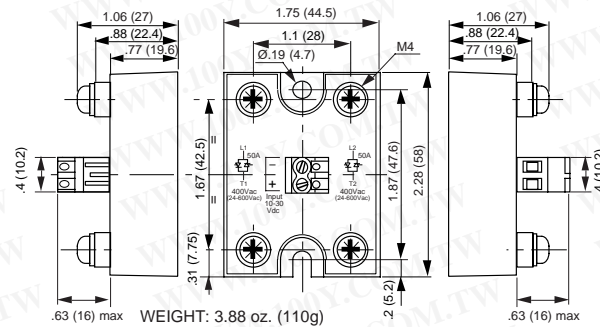

Figure 2d — SD48D50A; dimensions in inches (mm)

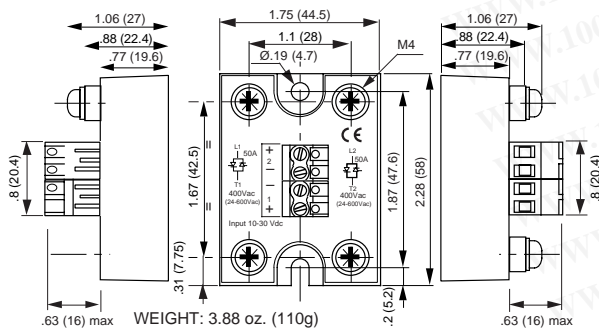

Figure 2e — SD48D50A2; dimensions in inches (mm)

TYPICAL APPLICATION

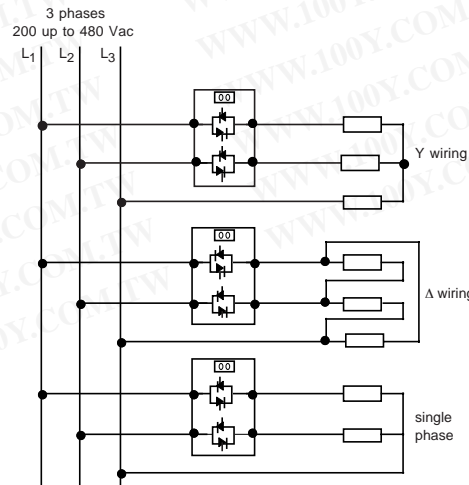

Figure 3 — SD48D50A

OUTPUT (LOAD) SPECIFICATION

	Input Type	Min	Max	Units
Operating Range				
SD24	R/D	12	280	Vrms
SD48D40-06		24	510	Vrms
SD48D50XX		24	600	Vrms

Peak Voltage

SD24			600	Vpeak
SD48			1200	Vpeak

Load Current Range (Resistive)

SD48D40-06		.005	40	Arms
All other relays		.005	50	Arms

Maximum Surge Current Rating (Non-Repetitive)

SD48D40-06			350	A
All other relays			550	A

On-State Voltage Drop

All relays output current			1.6	V
---------------------------	--	--	-----	---

Zero-Cross Window

SD	R		NA	
SD	D/A		±12	Vac

Off-State Leakage Current (60Hz)

SD48D40-06			2.5	mA
All other relays			1	mA

Turn-On Time (60 Hz)

SD24	R		0.1	ms
All other relays			8.3	ms

Turn-Off Time (60 Hz)

All relays			8.3	ms
------------	--	--	-----	----

Off-State dv/dt

All relays			500	V/μs
------------	--	--	-----	------

Maximum di/dt (Non-Repetitive)

All relays			50	A/μs
------------	--	--	----	------

Operating Frequency Range

All relays		10	440	Hz
------------	--	----	-----	----

OUTPUT (LOAD) SPECIFICATION (Continued)

	Input Type	Min	Max	Units
I^2t for Match Fusing (<8.3ms)				
SD48D40-06			612	A ² S
All other relays			1500	A ² S

CONTROL CHARACTERISTICS

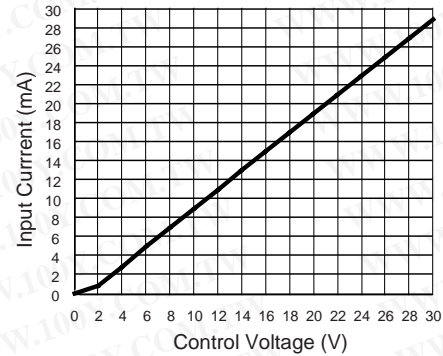

Figure 4a — SD24 and SD48D40-06 relays

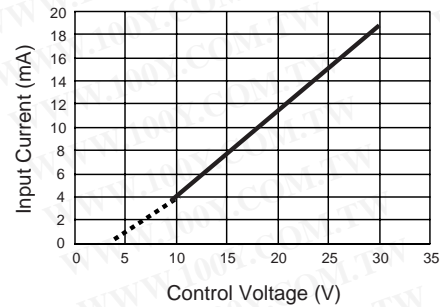

Figure 4b — SD48D50A relay

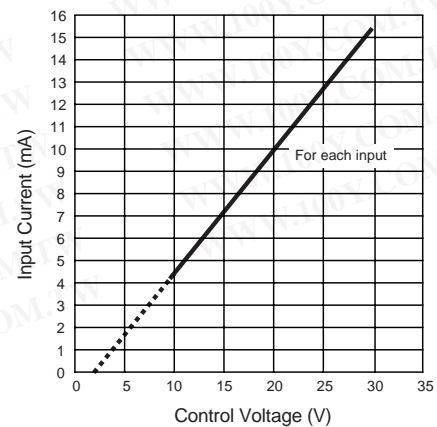

Figure 4c — SD48D50A2 relay

ENVIRONMENTAL SPECIFICATION

	Min	Max	Units
Operating Temperature	-40	100	°C
Storage Temperature	-40	100	°C
Input-Output Isolation			
SD48D40-06	4000		Vrms
All other relays	3300		Vrms
Output-Case Isolation			
SD48D40-06	2500		Vrms
All other relays	3300		Vrms
Output to Output			
SD48D50XX	3300		Vrms
All other relays	2500		Vrms
Junction-Case Thermal Resistance			
SD48D40-06		1.1	°C/W
All other relays		0.5	°C/W

THERMAL CHARACTERISTICS

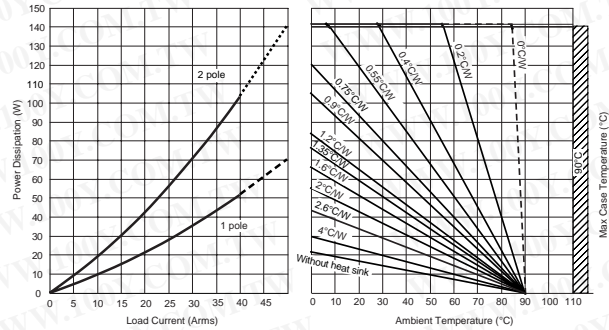

Figure 6a — SD24 relays output current

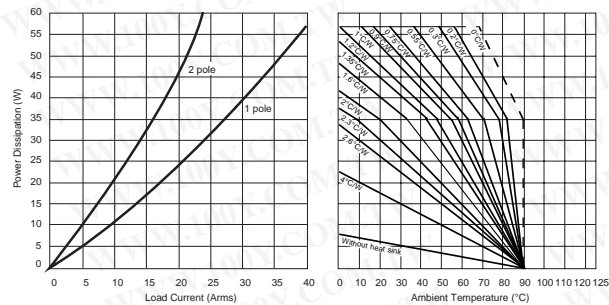

Figure 6b — SD48D40-06 output current

SURGE CURRENT

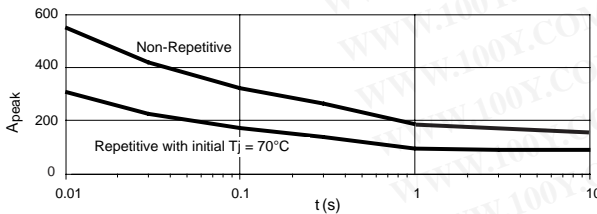

Figure 5a — SD24 50A output current

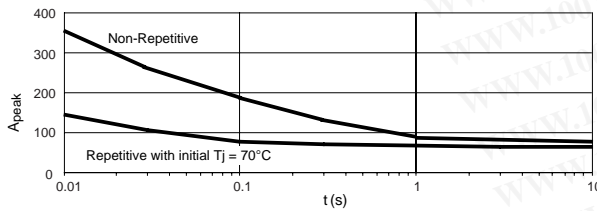

Figure 5b — SD48 40A output current

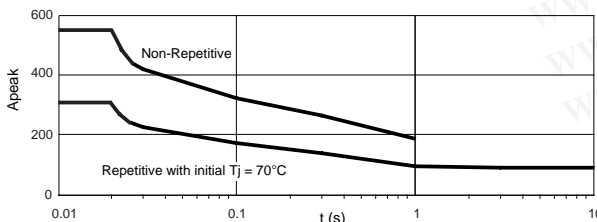

Figure 5c — SD48 50A output current

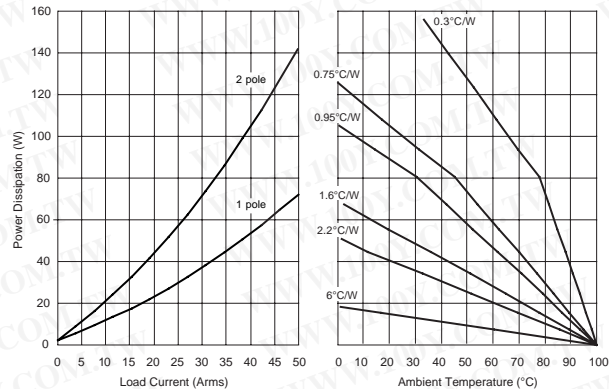

Figure 6c — SD48D50A and SD48D50A2 output current

NOTES:

1. Electrical specifications at 25°C unless otherwise specified.
2. For 800Hz applications, contact factory.
3. For additional/custom applications, contact factory.

OPTIONAL ADD-ONS

- Please order add-ons separately:
- -12 — Thermal pad installed.
 - -14 — Plastic touch-proof cover.