

SN74CBTD3861 10-BIT FET BUS SWITCH WITH LEVEL SHIFTING

SCDS084G – JULY 1998 – REVISED JULY 2002

- 5-Ω Switch Connection Between Two Ports
- TTL-Compatible Input Levels
- Designed to Be Used in Level-Shifting Applications

DB, DBQ, DGV, DW, OR PW PACKAGE
(TOP VIEW)

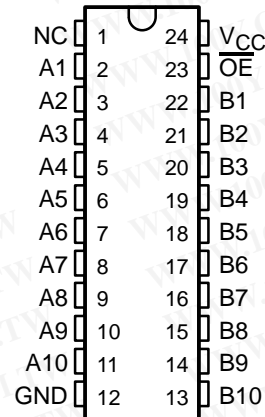

NC – No internal connection

description/ordering information

The SN74CBTD3861 provides ten bits of high-speed TTL-compatible bus switching. The low on-state resistance of the switch allows connections to be made with minimal propagation delay. A diode to V_{CC} is integrated on the die to allow for level shifting from 5-V signals at the device inputs to 3.3-V signals at the device outputs.

The device is organized as one 10-bit switch with a single output-enable (\overline{OE}) input. When \overline{OE} is low, the switch is on, and port A is connected to port B. When \overline{OE} is high, the switch is open, and the high-impedance state exists between the two ports.

ORDERING INFORMATION

T_A	PACKAGE†		ORDERABLE PART NUMBER	TOP-SIDE MARKING
-40°C to 85°C	SOIC – DW	Tube	SN74CBTD3861DW	CBTD3861
		Tape and reel	SN74CBTD3861DWR	
	SSOP – DB	Tape and reel	SN74CBTD3861DBR	CC861
	SSOP (QSOP) – DBQ	Tape and reel	SN74CBTD3861DBQR	CBTD3861
	TSSOP – PW	Tape and reel	SN74CBTD3861PWR	CC861
	TVSOP – DGV	Tape and reel	SN74CBTD3861DGV	CC861

† Package drawings, standard packing quantities, thermal data, symbolization, and PCB design guidelines are available at www.ti.com/sc/package.

FUNCTION TABLE

INPUT \overline{OE}	FUNCTION
L	A port = B port
H	Disconnect

勝特力材料 886-3-5753170
 勝特力电子(上海) 86-21-54151736
 勝特力电子(深圳) 86-755-83298787
[Http://www.100y.com.tw](http://www.100y.com.tw)



Please be aware that an important notice concerning availability, standard warranty, and use in critical applications of Texas Instruments semiconductor products and disclaimers thereto appears at the end of this data sheet.

PRODUCTION DATA information is current as of publication date. Products conform to specifications per the terms of Texas Instruments standard warranty. Production processing does not necessarily include testing of all parameters.

 **TEXAS
INSTRUMENTS**

POST OFFICE BOX 655303 • DALLAS, TEXAS 75265

Copyright © 2002, Texas Instruments Incorporated

SN74CBTD3861 10-BIT FET BUS SWITCH WITH LEVEL SHIFTING

SCDS084G – JULY 1998 – REVISED JULY 2002

logic diagram (positive logic)

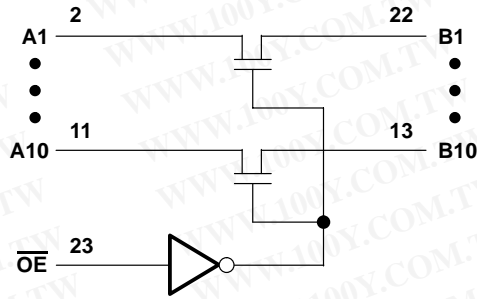

勝特力材料 886-3-5753170
 勝特力电子(上海) 86-21-54151736
 勝特力电子(深圳) 86-755-83298787
[Http://www.100y.com.tw](http://www.100y.com.tw)

absolute maximum ratings over operating free-air temperature range (unless otherwise noted)†

Supply voltage range, V_{CC}	-0.5 V to 7 V
Input voltage range, V_I (see Note 1)	-0.5 V to 7 V
Continuous channel current	128 mA
Input clamp current, I_{IK} ($V_{I/O} < 0$)	-50 mA
Package thermal impedance, θ_{JA} (see Note 2):	
DB package	63°C/W
DBQ package	61°C/W
DGV package	86°C/W
DW package	46°C/W
PW package	88°C/W
Storage temperature range, T_{stg}	-65°C to 150°C

† Stresses beyond those listed under “absolute maximum ratings” may cause permanent damage to the device. These are stress ratings only, and functional operation of the device at these or any other conditions beyond those indicated under “recommended operating conditions” is not implied. Exposure to absolute-maximum-rated conditions for extended periods may affect device reliability.

- NOTES: 1. The input and output negative-voltage ratings may be exceeded if the input and output clamp-current ratings are observed.
 2. The package thermal impedance is calculated in accordance with JESD 51-7.

recommended operating conditions (see Note 3)

	MIN	MAX	UNIT
V_{CC} Supply voltage	4.5	5.5	V
V_{IH} High-level control input voltage	2		V
V_{IL} Low-level control input voltage		0.8	V
T_A Operating free-air temperature	-40	85	°C

In applications with fast edge rates, multiple outputs switching, and operating at high frequencies, the output may have little or no level-shifting effect.

NOTE 3: All unused control inputs of the device must be held at V_{CC} or GND to ensure proper device operation. Refer to the TI application report, *Implications of Slow or Floating CMOS Inputs*, literature number SCBA004.



SN74CBTD3861
10-BIT FET BUS SWITCH
WITH LEVEL SHIFTING

SCDS084G – JULY 1998 – REVISED JULY 2002

electrical characteristics over recommended operating free-air temperature range (unless otherwise noted)

PARAMETER		TEST CONDITIONS		MIN	TYP†	MAX	UNIT
V_{IK}		$V_{CC} = 4.5\text{ V}$,	$I_I = -18\text{ mA}$			-1.2	V
V_{OH}		See Figure 2					
I_I		$V_{CC} = 5.5\text{ V}$,	$V_I = 5.5\text{ V}$ or GND			± 1	μA
I_{CC}		$V_{CC} = 5.5\text{ V}$,	$I_O = 0$,			1.5	mA
ΔI_{CC}^\ddagger		$V_{CC} = 5.5\text{ V}$,	One input at 3.4 V, Other inputs at V_{CC} or GND			2.5	mA
C_i		$V_I = 3\text{ V}$ or 0			2.5		pF
$C_{iO(OFF)}$		$V_O = 3\text{ V}$ or 0,	$\overline{OE} = V_{CC}$		4		pF
r_{on}^\S		$V_{CC} = 4.5\text{ V}$	$V_I = 0$	$I_I = 64\text{ mA}$	5	7	Ω
				$I_I = 30\text{ mA}$	5	7	
			$V_I = 2.4\text{ V}$,	$I_I = 15\text{ mA}$	20	50	

† All typical values are at $V_{CC} = 5\text{ V}$, $T_A = 25^\circ\text{C}$.

‡ This is the increase in supply current for each input that is at the specified TTL voltage level rather than V_{CC} or GND.

§ Measured by the voltage drop between the A and B terminals at the indicated current through the switch. On-state resistance is determined by the lowest voltage of the two (A or B) terminals.

switching characteristics over recommended operating free-air temperature range (unless otherwise noted) (see Figure 1)

PARAMETER	FROM (INPUT)	TO (OUTPUT)	MIN	MAX	UNIT
t_{pd}^{\parallel}	A or B	B or A		0.35	ns
t_{en}	\overline{OE}	A or B	2.6	10	ns
t_{dis}	\overline{OE}	A or B	1	6	ns

\parallel The propagation delay is the calculated RC time constant of the typical on-state resistance of the switch and the specified load capacitance, when driven by an ideal voltage source (zero output impedance).

勝特力材料 886-3-5753170
 勝特力电子(上海) 86-21-54151736
 勝特力电子(深圳) 86-755-83298787
[Http://www.100y.com.tw](http://www.100y.com.tw)

SN74CBTD3861 10-BIT FET BUS SWITCH WITH LEVEL SHIFTING

SCDS084G – JULY 1998 – REVISED JULY 2002

PARAMETER MEASUREMENT INFORMATION

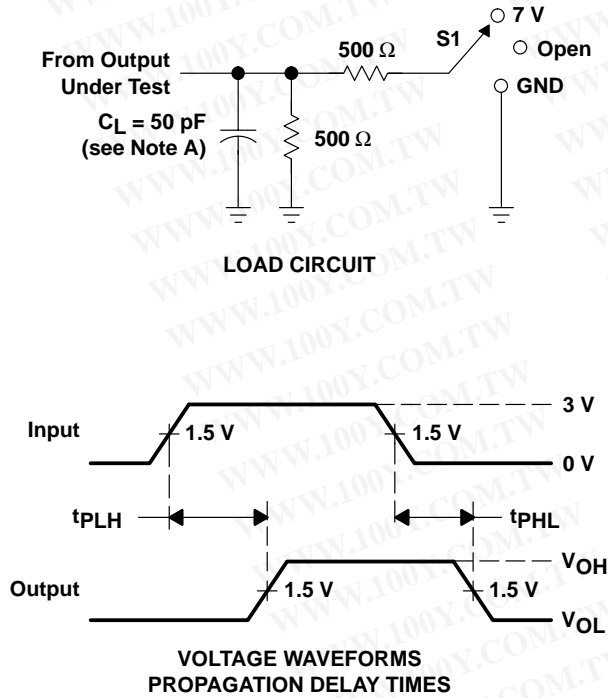

TEST	S1
t _{pd}	Open
t _{PLZ} /t _{PZL}	7 V
t _{PHZ} /t _{PZH}	Open

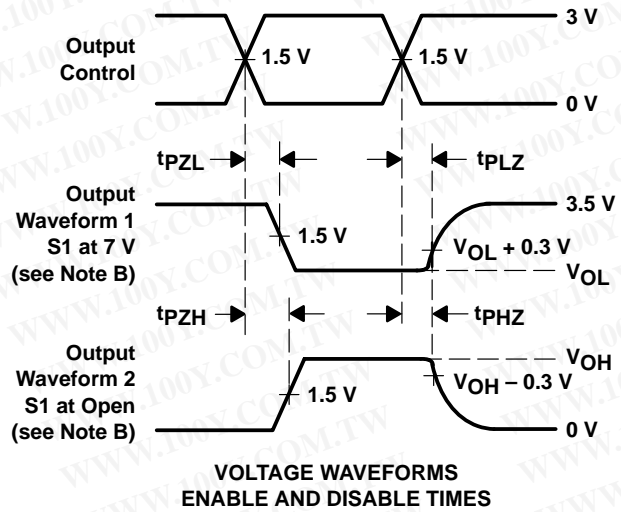

- NOTES:
- A. C_L includes probe and jig capacitance.
 - B. Waveform 1 is for an output with internal conditions such that the output is low except when disabled by the output control. Waveform 2 is for an output with internal conditions such that the output is high except when disabled by the output control.
 - C. All input pulses are supplied by generators having the following characteristics: PRR ≤ 10 MHz, Z_O = 50 Ω, t_r ≤ 2.5 ns, t_f ≤ 2.5 ns.
 - D. The outputs are measured one at a time with one transition per measurement.
 - E. t_{PLZ} and t_{PHZ} are the same as t_{dis}.
 - F. t_{PZL} and t_{PZH} are the same as t_{en}.
 - G. t_{PLH} and t_{PHL} are the same as t_{pd}.

Figure 1. Load Circuit and Voltage Waveforms

勝特力材料 886-3-5753170
 勝特力电子(上海) 86-21-54151736
 勝特力电子(深圳) 86-755-83298787
[Http://www.100y.com.tw](http://www.100y.com.tw)

TYPICAL CHARACTERISTICS

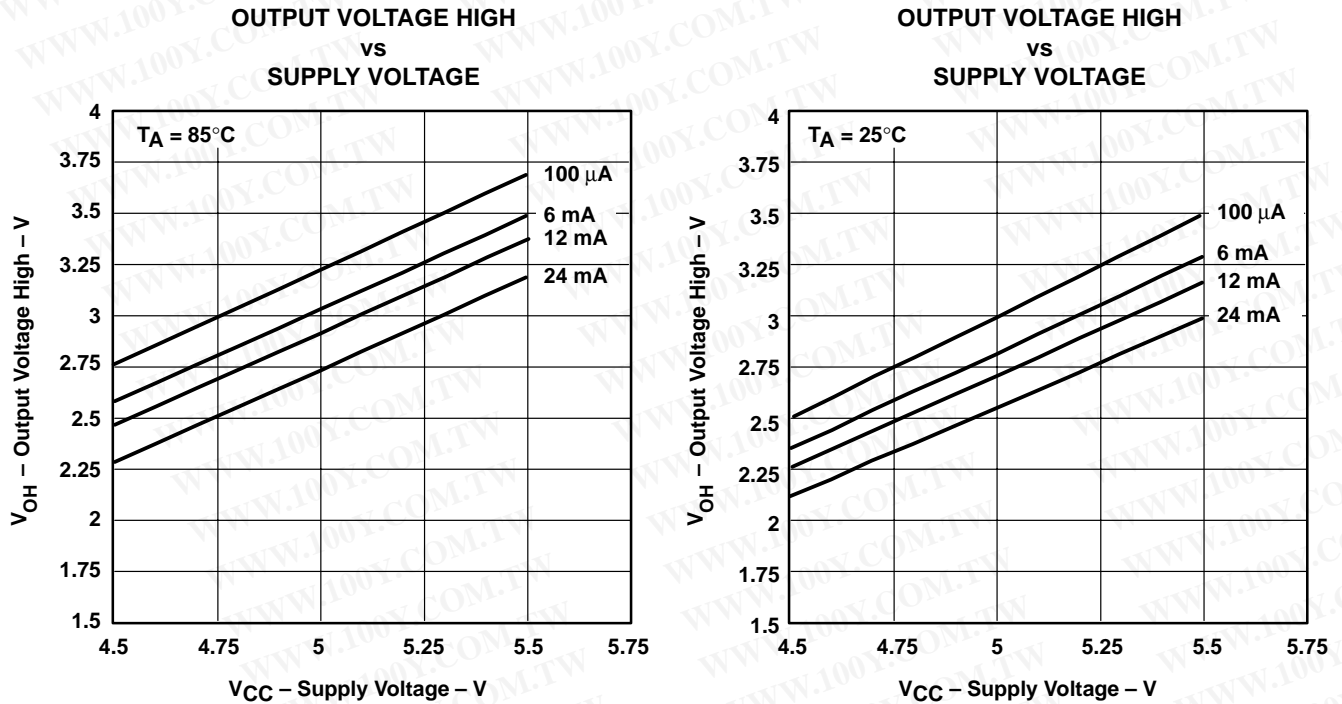

勝特力材料 886-3-5753170
 勝特力电子(上海) 86-21-54151736
 勝特力电子(深圳) 86-755-83298787
[Http://www.100y.com.tw](http://www.100y.com.tw)

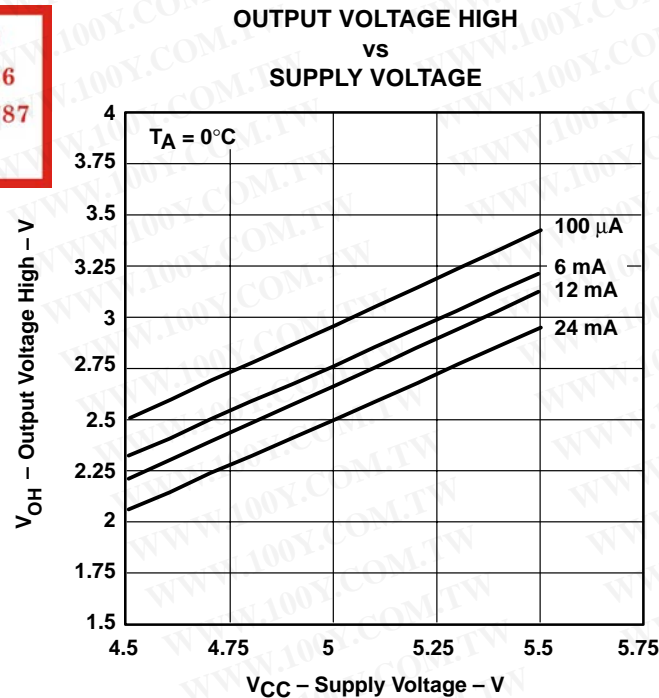

Figure 2. V_{OH} Values

IMPORTANT NOTICE

Texas Instruments Incorporated and its subsidiaries (TI) reserve the right to make corrections, modifications, enhancements, improvements, and other changes to its products and services at any time and to discontinue any product or service without notice. Customers should obtain the latest relevant information before placing orders and should verify that such information is current and complete. All products are sold subject to TI's terms and conditions of sale supplied at the time of order acknowledgment.

TI warrants performance of its hardware products to the specifications applicable at the time of sale in accordance with TI's standard warranty. Testing and other quality control techniques are used to the extent TI deems necessary to support this warranty. Except where mandated by government requirements, testing of all parameters of each product is not necessarily performed.

TI assumes no liability for applications assistance or customer product design. Customers are responsible for their products and applications using TI components. To minimize the risks associated with customer products and applications, customers should provide adequate design and operating safeguards.

TI does not warrant or represent that any license, either express or implied, is granted under any TI patent right, copyright, mask work right, or other TI intellectual property right relating to any combination, machine, or process in which TI products or services are used. Information published by TI regarding third-party products or services does not constitute a license from TI to use such products or services or a warranty or endorsement thereof. Use of such information may require a license from a third party under the patents or other intellectual property of the third party, or a license from TI under the patents or other intellectual property of TI.

Reproduction of information in TI data books or data sheets is permissible only if reproduction is without alteration and is accompanied by all associated warranties, conditions, limitations, and notices. Reproduction of this information with alteration is an unfair and deceptive business practice. TI is not responsible or liable for such altered documentation.

Resale of TI products or services with statements different from or beyond the parameters stated by TI for that product or service voids all express and any implied warranties for the associated TI product or service and is an unfair and deceptive business practice. TI is not responsible or liable for any such statements.

勝特力材料 886-3-5753170
勝特力电子(上海) 86-21-54151736
勝特力电子(深圳) 86-755-83298787
[Http://www.100y.com.tw](http://www.100y.com.tw)

Mailing Address:

Texas Instruments
Post Office Box 655303
Dallas, Texas 75265