

勝特力材料 886-3-5753170
 勝特力电子(上海) 86-21-54151736
 勝特力电子(深圳) 86-755-83298787
 Http://www.100y.com.tw



BU931 BU931P

HIGH VOLTAGE IGNITION COIL DRIVER NPN POWER DARLINGTON

- VERY RUGGED BIPOLAR TECHNOLOGY
- HIGH OPERATING JUNCTION TEMPERATURE
- WIDE RANGE OF PACKAGES

APPLICATIONS

- HIGH RUGGEDNESS ELECTRONIC IGNITIONS

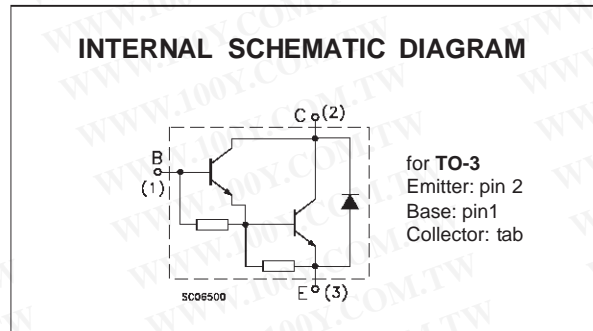
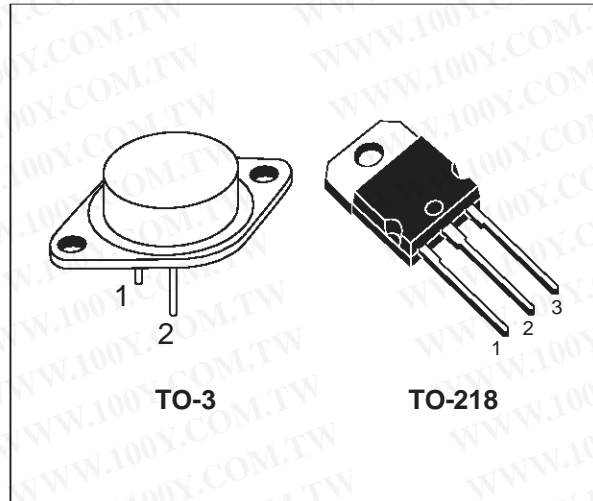

ABSOLUTE MAXIMUM RATINGS

Symbol	Parameter	Value		Unit
		BU931	BU931P	
V_{CES}	Collector-Emitter Voltage ($V_{BE} = 0$)	500		V
V_{CEO}	Collector-Emitter Voltage ($I_B = 0$)	400		V
V_{EBO}	Emitter-Base Voltage ($I_C = 0$)	5		V
I_C	Collector Current	15		A
I_{CM}	Collector Peak Current	30		A
I_B	Base Current	1		A
I_{BM}	Base Peak Current	5		A
P_{tot}	Total Dissipation at $T_C = 25^\circ C$	175	135	W
T_{stg}	Storage Temperature	-65 to 200	-65 to 175	$^\circ C$
T_j	Max. Operating Junction Temperature	200	175	$^\circ C$

BU931 / BU931P

THERMAL DATA

		TO-3	TO-218	
R _{thj-case}	Thermal Resistance Junction-case Max	1	1.1	°C/W

ELECTRICAL CHARACTERISTICS (T_{case} = 25 °C unless otherwise specified)

Symbol	Parameter	Test Conditions	Min.	Typ.	Max.	Unit
I _{CES}	Collector Cut-off Current (V _{BE} = 0)	V _{CE} = 500 V V _{CE} = 500 V T _j = 125 °C			100 0.5	μA mA
I _{CEO}	Collector Cut-off Current (I _B = 0)	V _{CE} = 450 V V _{CE} = 450 V T _j = 125 °C			100 0.5	μA mA
I _{EBO}	Emitter Cut-off Current (I _C = 0)	V _{EB} = 5 V			20	mA
V _{CEO(sus)*}	Collector-Emitter Sustaining Voltage (I _B = 0)	I _C = 100 mA L = 10 mH V _{Clamp} = 400 V (See Fig.4)	400			V
V _{CE(sat)*}	Collector-Emitter Saturation Voltage	I _C = 7 A I _B = 70 mA I _C = 8 A I _B = 100 mA I _C = 10 A I _B = 250 mA			1.6 1.8 1.8	V V V
V _{BE(sat)*}	Base-Emitter Saturation Voltage	I _C = 7 A I _B = 70 mA I _C = 8 A I _B = 100 mA I _C = 10 A I _B = 250 mA			2.2 2.4 2.5	V V V
h _{FE*}	DC Current Gain	I _C = 5 A V _{CE} = 10 V	300			
V _F	Diode Forward Voltage	I _F = 10 A			2.5	V
	Functional Test (see fig. 1)	V _{CC} = 24 V V _{clamp} = 400 V L = 7 mH	8			A
t _s	INDUCTIVE LOAD Storage Time	V _{CC} = 12 V V _{clamp} = 300 V L = 7 mH		15		μs
t _f	Fall Time (see fig. 3)	I _C = 7 A I _B = 70 mA V _{BE} = 0 R _{BE} = 47 Ω		0.5		μs

* Pulsed: Pulse duration = 300 μs, duty cycle 1.5 %

Safe Operating Area

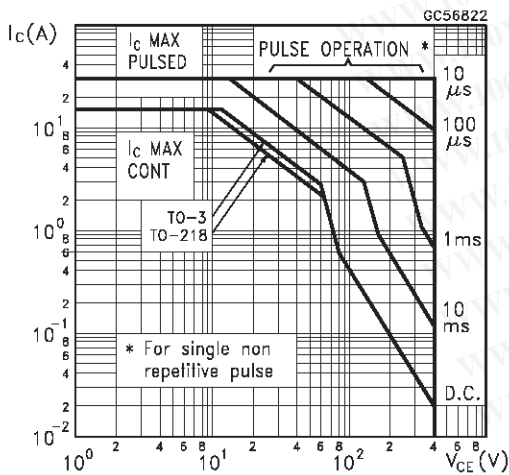

DC Current Gain

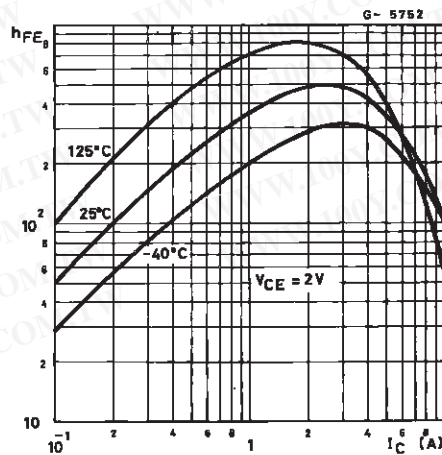

Collector Emitter Saturation Voltage

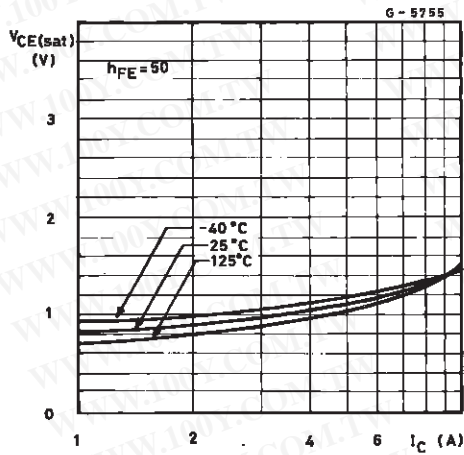

Collector Emitter Saturation Voltage

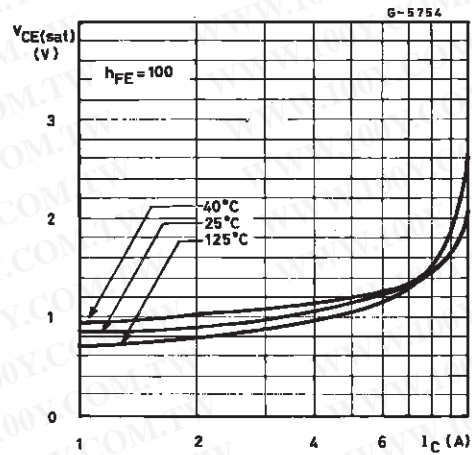

Collector Emitter Saturation Voltage

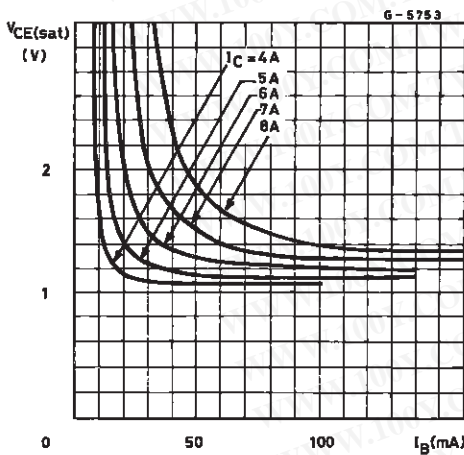

Base Emitter Saturation Voltage

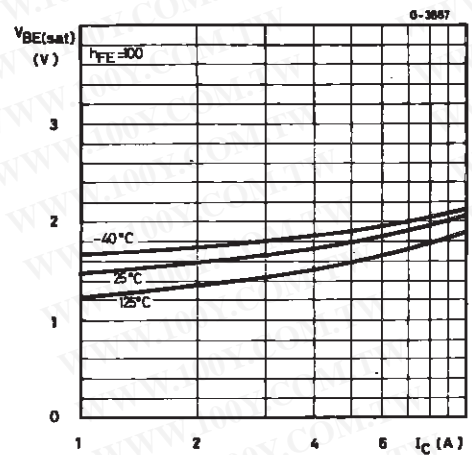

Base Emitter Saturation Voltage

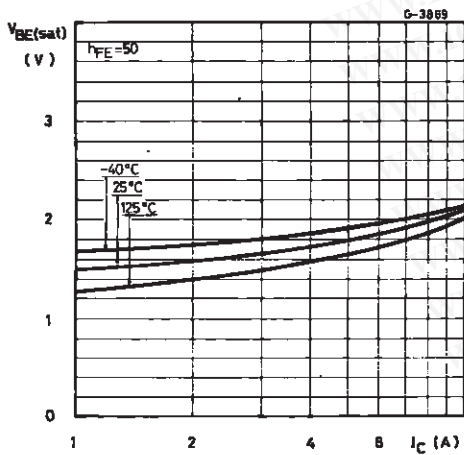

Switching Time Inductive Load

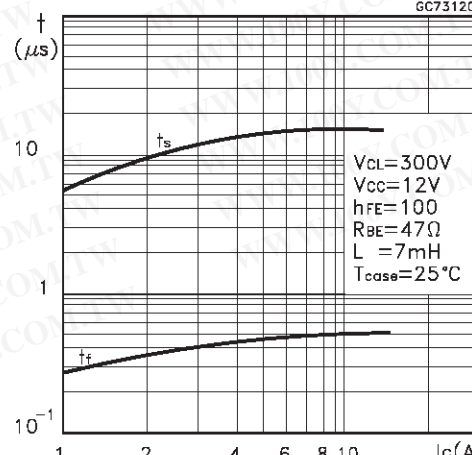

BU931 / BU931P

FIGURE 1: Functional Test Circuit

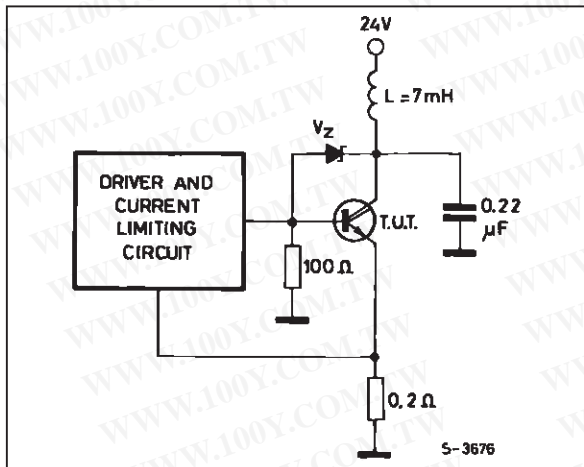

FIGURE 2: Functional Test Waveforms

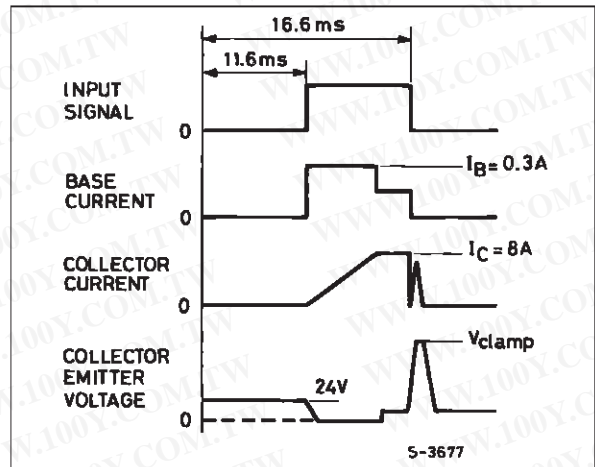

FIGURE 3: Switching Time Test Circuit

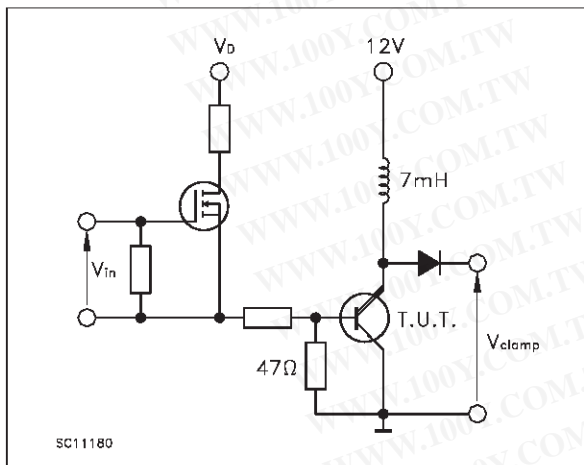
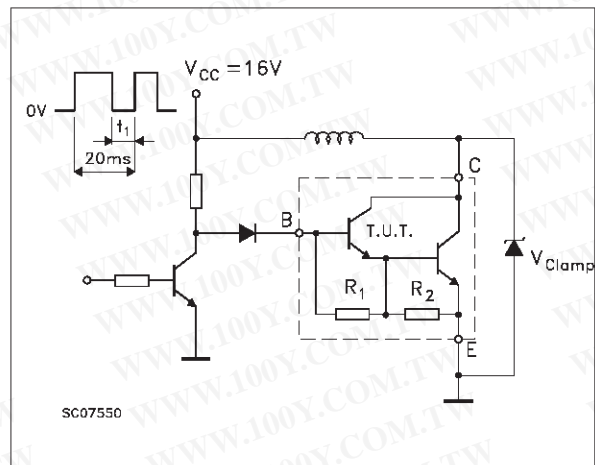
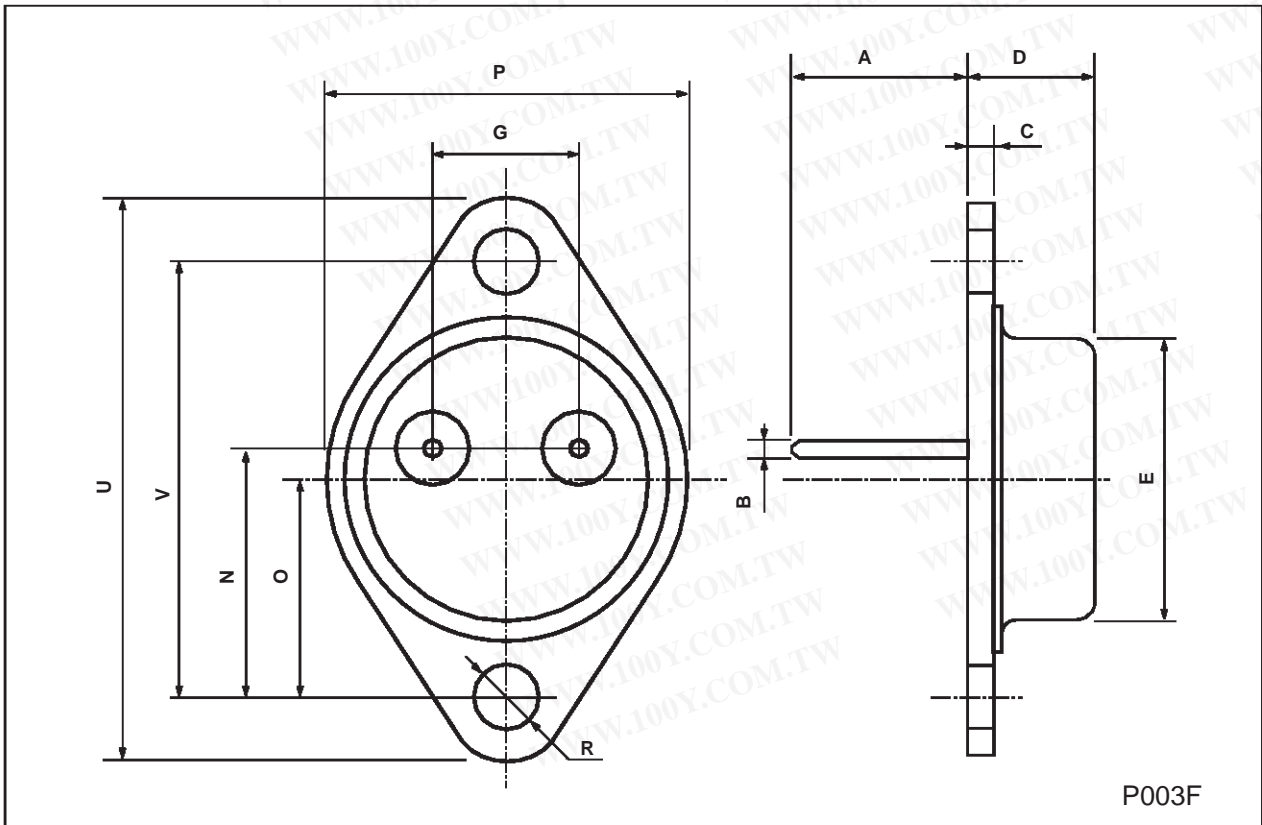

FIGURE 4: Sustaining Voltage Test Circuit



TO-3 MECHANICAL DATA

DIM.	mm			inch		
	MIN.	TYP.	MAX.	MIN.	TYP.	MAX.
A	11.00		13.10	0.433		0.516
B	0.97		1.15	0.038		0.045
C	1.50		1.65	0.059		0.065
D	8.32		8.92	0.327		0.351
E	19.00		20.00	0.748		0.787
G	10.70		11.10	0.421		0.437
N	16.50		17.20	0.649		0.677
P	25.00		26.00	0.984		1.023
R	4.00		4.09	0.157		0.161
U	38.50		39.30	1.515		1.547
V	30.00		30.30	1.187		1.193



勝特力材料 886-3-5753170
 勝特力电子(上海) 86-21-54151736
 勝特力电子(深圳) 86-755-83298787
[Http://www.100y.com.tw](http://www.100y.com.tw)

BU931 / BU931P

TO-218 (SOT-93) MECHANICAL DATA

DIM.	mm			inch		
	MIN.	TYP.	MAX.	MIN.	TYP.	MAX.
A	4.7		4.9	0.185		0.193
C	1.17		1.37	0.046		0.054
D		2.5			0.098	
E	0.5		0.78	0.019		0.030
F	1.1		1.3	0.043		0.051
G	10.8		11.1	0.425		0.437
H	14.7		15.2	0.578		0.598
L2	-		16.2	-		0.637
L3		18			0.708	
L5	3.95		4.15	0.155		0.163
L6		31			1.220	
R	-		12.2	-		0.480
Ø	4		4.1	0.157		0.161

