



BD909/911
BD910/912

COMPLEMENTARY SILICON POWER TRANSISTORS

- STMicroelectronics PREFERRED SALESTYPES

DESCRIPTION

The BD909 and BD911 are silicon Epitaxial-Base NPN power transistors mounted in Jedec TO-220 plastic package. They are intended for use in power linear and switching applications.

The complementary PNP types are BD910 and BD912 respectively.

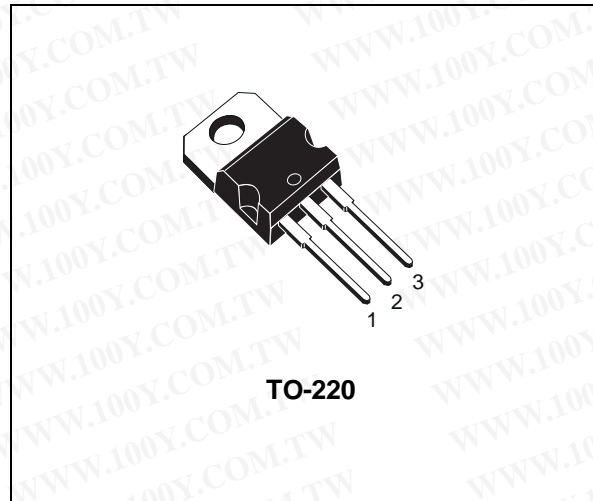

勝特力材料 886-3-5753170
 勝特力电子(上海) 86-21-54151736
 勝特力电子(深圳) 86-755-83298787
[Http://www.100y.com.tw](http://www.100y.com.tw)

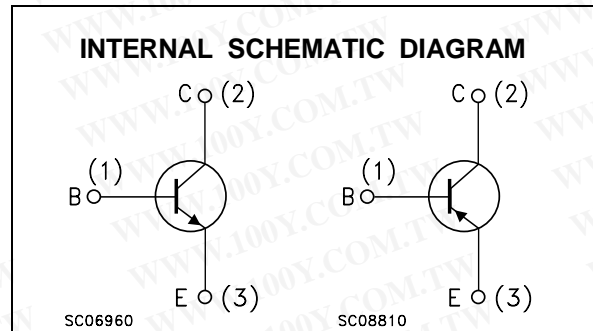

ABSOLUTE MAXIMUM RATINGS

Symbol	Parameter	Value		Unit	
		NPN	BD909		BD911
		PNP	BD910		BD912
V_{CBO}	Collector-Base Voltage ($I_E = 0$)		80	100	V
V_{CEO}	Collector-Emitter Voltage ($I_B = 0$)		80	100	V
V_{EBO}	Emitter-Base Voltage ($I_C = 0$)		5		V
$I_{E,IC}$	Collector Current		15		A
I_B	Base Current		5		A
P_{tot}	Total Dissipation at $T_c \leq 25^\circ C$		90		W
T_{stg}	Storage Temperature		-65 to 150		$^\circ C$
T_j	Max. Operating Junction Temperature		150		$^\circ C$

For PNP types voltage and current values are negative.

BD909 / BD910 / BD911 / BD912

THERMAL DATA

R _{thj-case}	Thermal Resistance Junction-case	Max	1.4	°C/W
-----------------------	----------------------------------	-----	-----	------

ELECTRICAL CHARACTERISTICS (T_{case} = 25 °C unless otherwise specified)

Symbol	Parameter	Test Conditions	Min.	Typ.	Max.	Unit
I _{CBO}	Collector Cut-off Current (I _E = 0)	for BD909/910 V _{CB} = 80 V			500	μA
		for BD911/912 V _{CB} = 100 V			500	μA
		for BD909/910 V _{CB} = 80 V			5	mA
		for BD911/912 V _{CB} = 100 V			5	mA
I _{CEO}	Collector Cut-off Current (I _B = 0)	for BD909/910 V _{CE} = 40 V			1	mA
		for BD911/912 V _{CE} = 50 V			1	mA
I _{EBO}	Emitter Cut-off Current (I _C = 0)	V _{EB} = 5 V			1	mA
V _{CEO(sus)*}	Collector-Emitter Sustaining Voltage (I _B = 0)	I _C = 100 mA	for BD909/910	80		V
			for BD911/912	100		V
V _{CE(sat)*}	Collector-Emitter Saturation Voltage	I _C = 5 A	I _B = 0.5 A		1	V
		I _C = 10 A	I _B = 2.5 A		3	V
V _{BE(sat)*}	Base-Emitter Saturation Voltage	I _C = 10 A	I _B = 2.5 A		2.5	V
V _{BE*}	Base-Emitter Voltage	I _C = 5 A	V _{CE} = 4 V		1.5	V
h _{FE*}	DC Current Gain	I _C = 0.5 A	V _{CE} = 4 V	40		250
		I _C = 5 A	V _{CE} = 4 V	15		150
		I _C = 10 A	V _{CE} = 4 V	5		
f _T	Transition frequency	I _C = 0.5 A	V _{CE} = 4 V	3		MHz

* Pulsed: Pulse duration = 300 μs, duty cycle 1.5 %
 For PNP types voltage and current values are negative.

Safe Operating Area

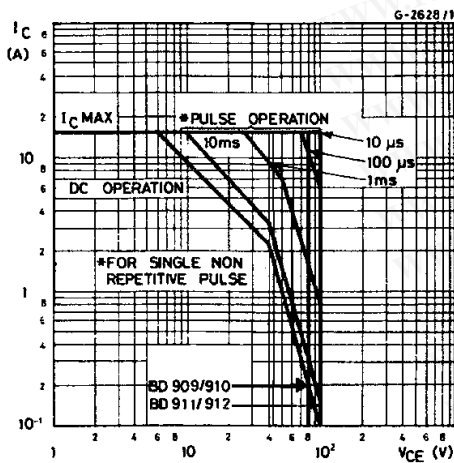

Derating Curves

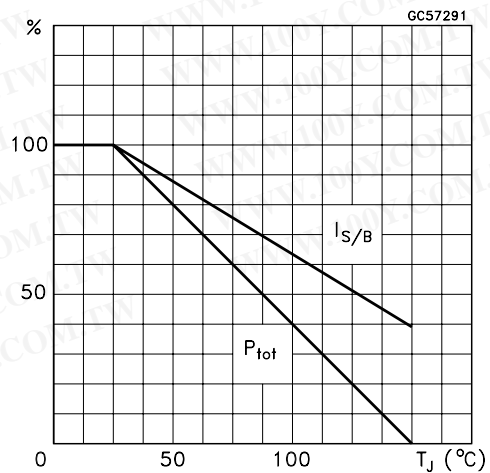

DC Current Gain (NPN type)

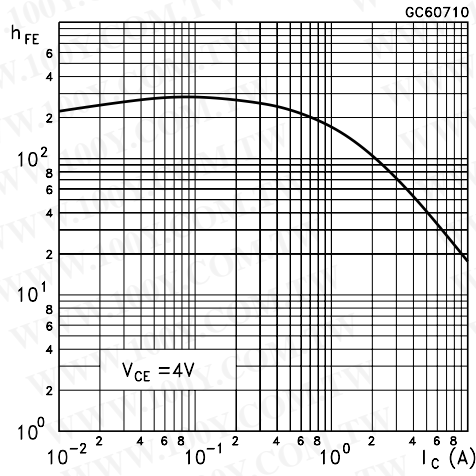

DC Current Gain (PNP type)

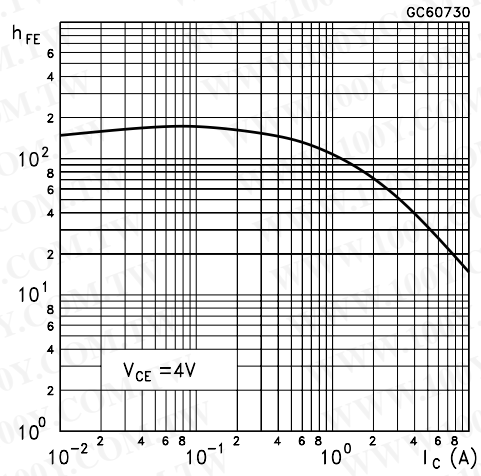

DC Transconductance (NPN type)

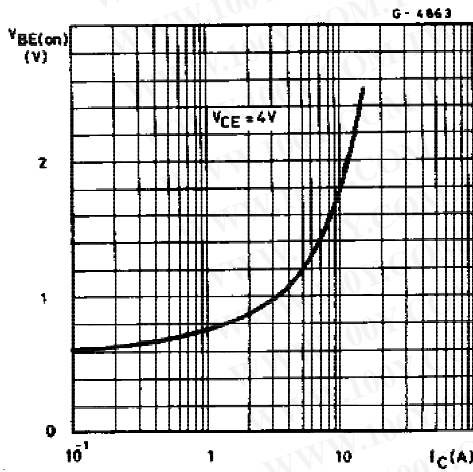

DC Transconductance (PNP type)

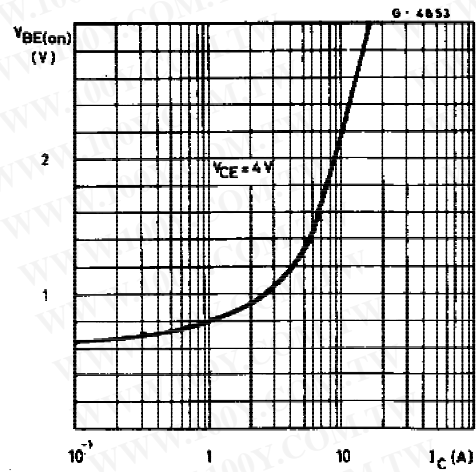

Collector-Emitter Saturation Voltage (NPN type)

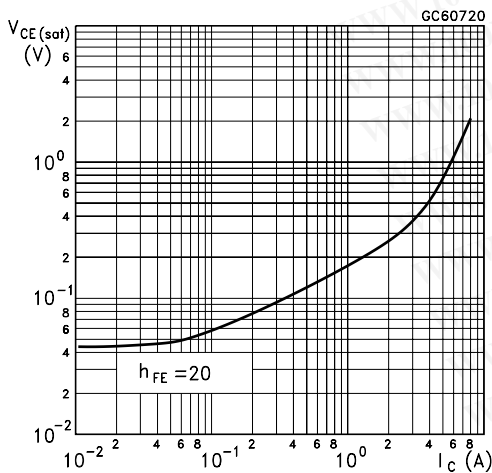

Collector-Emitter Saturation Voltage (PNP type)

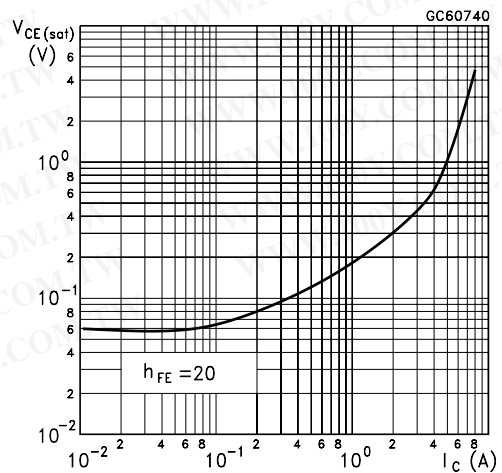

BD909 / BD910 / BD911 / BD912

Base-Emitter Saturation Voltage (NPN type)

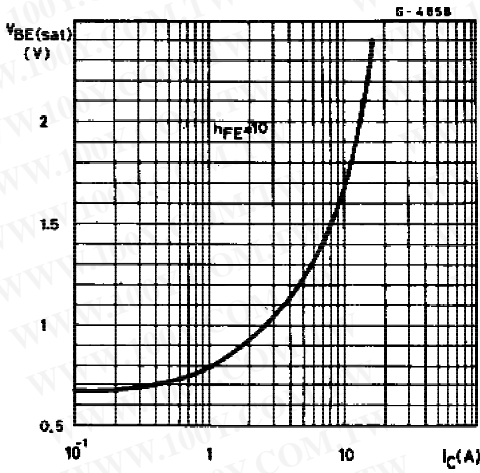

Base-Emitter Saturation Voltage (PNP type)

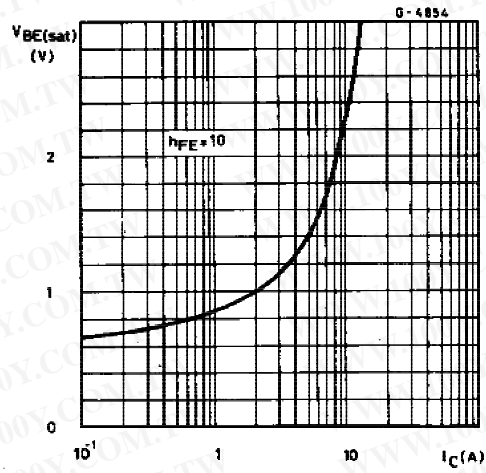

Transition Frequency (NPN type)

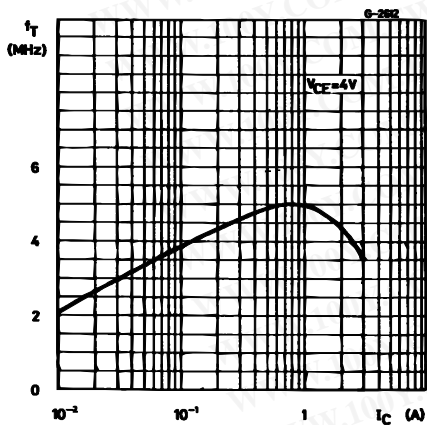

Transition Frequency (PNP type)

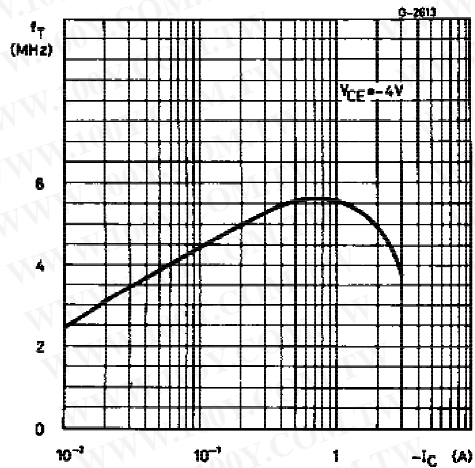

勝特力材料 886-3-5753170
 勝特力电子(上海) 86-21-54151736
 勝特力电子(深圳) 86-755-83298787
[Http://www.100y.com.tw](http://www.100y.com.tw)

TO-220 MECHANICAL DATA

DIM.	mm			inch		
	MIN.	TYP.	MAX.	MIN.	TYP.	MAX.
A	4.40		4.60	0.173		0.181
C	1.23		1.32	0.048		0.051
D	2.40		2.72	0.094		0.107
D1		1.27			0.050	
E	0.49		0.70	0.019		0.027
F	0.61		0.88	0.024		0.034
F1	1.14		1.70	0.044		0.067
F2	1.14		1.70	0.044		0.067
G	4.95		5.15	0.194		0.203
G1	2.4		2.7	0.094		0.106
H2	10.0		10.40	0.393		0.409
L2		16.4			0.645	
L4	13.0		14.0	0.511		0.551
L5	2.65		2.95	0.104		0.116
L6	15.25		15.75	0.600		0.620
L7	6.2		6.6	0.244		0.260
L9	3.5		3.93	0.137		0.154
DIA.	3.75		3.85	0.147		0.151

