

SMALL SIGNAL PNP TRANSISTORS

- SILICON EPITAXIAL PLANAR PNP TRANSISTORS
- MEDIUM POWER AMPLIFIER
- NPN COMPLEMENTS ARE 2N5320 AND 2N5321

DESCRIPTION

The 2N5322 and 2N5323 are silicon epitaxial planar PNP transistors in Jedec TO-39 metal case. They are especially intended for high-voltage medium power application in industrial and commercial equipments.

The complementary NPN types are respectively the 2N5320 and 2N5321

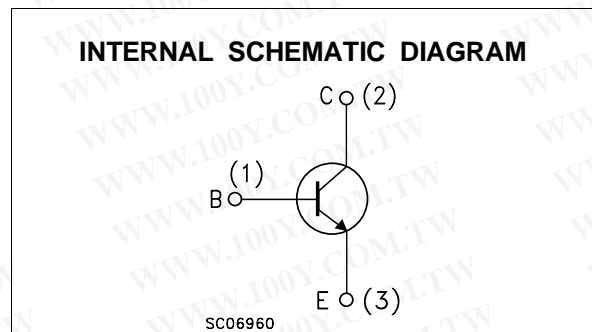
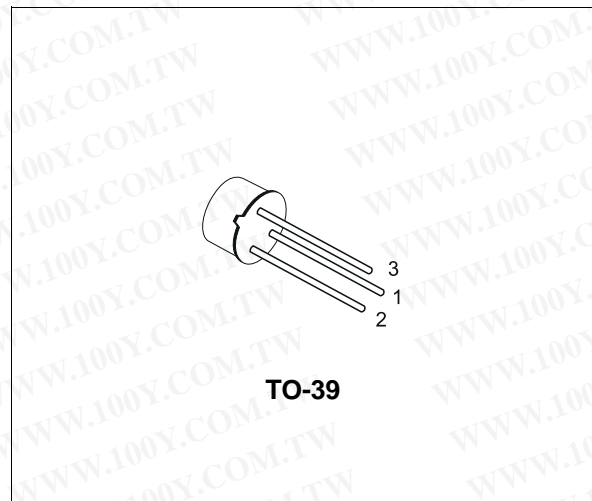

ABSOLUTE MAXIMUM RATINGS

Symbol	Parameter	Value		Unit
		2N5322	2N5323	
V_{CBO}	Collector-Base Voltage ($I_E = 0$)	-100	-75	V
V_{CEV}	Collector-Emitter Voltage ($V_{BE} = -1.5V$)	-100	-75	V
V_{CEO}	Collector-Emitter Voltage ($I_B = 0$)	-75	-50	V
V_{EBO}	Emitter-Base Voltage ($I_C = 0$)	-6	-5	V
I_C	Collector Current	-1.2		A
I_{CM}	Collector Peak Current	-2		A
I_B	Base Current	-1		A
P_{tot}	Total Dissipation at $T_{amb} = 25\text{ }^\circ\text{C}$	1		W
P_{tot}	Total Dissipation at $T_c = 25\text{ }^\circ\text{C}$	10		W
T_{stg}, T_j	Storage and Junction Temperature	-65 to 200		$^\circ\text{C}$

2N5322/2N5323

THERMAL DATA

R _{thj-case}	Thermal Resistance Junction-Case	Max	17.5	°C/W
R _{thj-amb}	Thermal Resistance Junction-Ambient	Max	175	°C/W

ELECTRICAL CHARACTERISTICS (T_{case} = 25 °C unless otherwise specified)

Symbol	Parameter	Test Conditions	Min.	Typ.	Max.	Unit
I _{CBO}	Collector Cut-off Current (I _E = 0)	V _{CB} = -80 V for 2N5322 V _{CB} = -60 V for 2N5323			-0.5 -5	μA μA
I _{EBO}	Collector Cut-off Current (I _C = 0)	V _{EB} = -5 V for 2N5322 V _{EB} = -4 V for 2N5323		-0.1 -0.5		μA μA
V _{(BR)CEV}	Collector-Emitter Breakdown Voltage (V _{BE} = 1.5V)	I _C = -100 μA for 2N5322 for 2N5323	-100 -75			V V
V _{(BR)CEO*}	Collector-Emitter Breakdown Voltage (I _B = 0)	I _C = -10 mA for 2N5322 for 2N5323	-75 -50			V V
V _{(BR)EBO}	Emitter-Base Breakdown Voltage (I _C = 0)	I _E = -100 μA for 2N5322 for 2N5323	-6 -5			V V
V _{CE(sat)*}	Collector-Emitter Saturation Voltage	I _C = -500 mA I _B = -50 mA for 2N5322 for 2N5323			-0.7 -1.2	V V
V _{BE*}	Base-Emitter Voltage	I _C = -500 mA V _{CE} = -4 V for 2N5322 for 2N5323			-1.1 -1.4	V V
h _{FE*}	DC Current Gain	for 2N5322 I _C = -500 mA V _{CE} = -4 V I _C = -1 A V _{CE} = -2 V for 2N5323 I _C = -500 mA V _{CE} = -4 V	30 10 40		130 250	
f _T	Transition Frequency	I _C = -50 mA V _{CE} = -4 V f = 10 MHz	50			MHz
t _{on}	Turn-on Time	I _C = -500 mA V _{CC} = -30 V I _{B1} = -50 mA			100	ns
t _{off}	Turn-off Time	I _C = -500 mA V _{CC} = -30 V I _{B1} = -I _{B2} = -50 mA			1000	ns

* Pulsed: Pulse duration = 300 μs, duty cycle = 1 %

勝特力材料 886-3-5753170
 勝特力电子(上海) 86-21-54151736
 勝特力电子(深圳) 86-755-83298787
[Http://www.100y.com.tw](http://www.100y.com.tw)

TO-39 MECHANICAL DATA

DIM.	mm			inch		
	MIN.	TYP.	MAX.	MIN.	TYP.	MAX.
A	12.7			0.500		
B			0.49			0.019
D			6.6			0.260
E			8.5			0.334
F			9.4			0.370
G	5.08			0.200		
H			1.2			0.047
I			0.9			0.035
L	45° (typ.)					

