



勝特力材料 886-3-5753170
 勝特力电子(上海) 86-21-54151736
 勝特力电子(深圳) 86-755-83298787
[Http://www.100y.com.tw](http://www.100y.com.tw)

ST75185

MULTIPLE RS-232 DRIVERS AND RECEIVERS

- MEETS AND EXCEEDS THE REQUIREMENTS OF EIA/TIA-232-E AND ITUV.28 STANDARD
- SINGLE CHIP WITH EASY INTERFACE BETWEEN UART AND SERIAL PORT CONNECTOR OF IBM PC/AT™ AND COMPATIBLES
- DESIGNED TO SUPPORT DATA RATES UP TO 120 Kbps
- PINOUT COMPATIBLE WITH ST75C185

DESCRIPTION

The ST75185 contains three drivers and five receivers. The pinout matches the DB9S connector design in order to decrease the part count, reduce the board space required and allow easy interconnection of the UART and serial port connector of IBM PC/AT™ and compatibles. The bipolar circuits and processing of the ST75185 provides a rugged low-cost solution for this function at the expense of quiescent power and external passive components relative to the ST75C185.

The ST75185 complies with the requirements of the EIA/TIA 232-E and ITU (formally CCITT) v.28

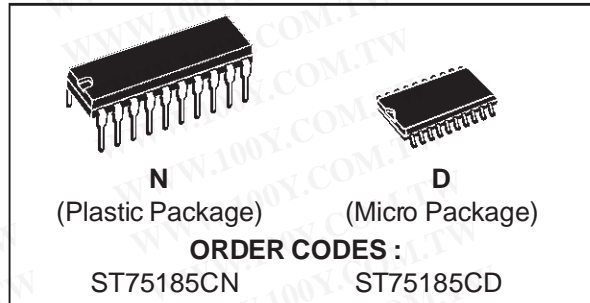

standards. These standards are for data interchange between a host computer and peripheral at signalling rates up to 20k-bits/s. The switching speeds of the ST75185 are fast enough to support rates up to 120K-bits/s with lower capacitive loads (shorter cables). Interoperability at the higher signalling rates cannot be assured unless the designer has design control of the cable and the interface circuits at the both ends. For interoperability at signalling rates to 120 K-bits/s, use of EIA/ITA-423-B (ITU v.10) and EIA/ITA-422-B (ITU v.11) standards are recommended.

The ST75185 is characterized for operation over the range of 0°C to 70°C.

PIN CONNECTION IEC LOGIC SYMBOL AND LOGIC DIAGRAM

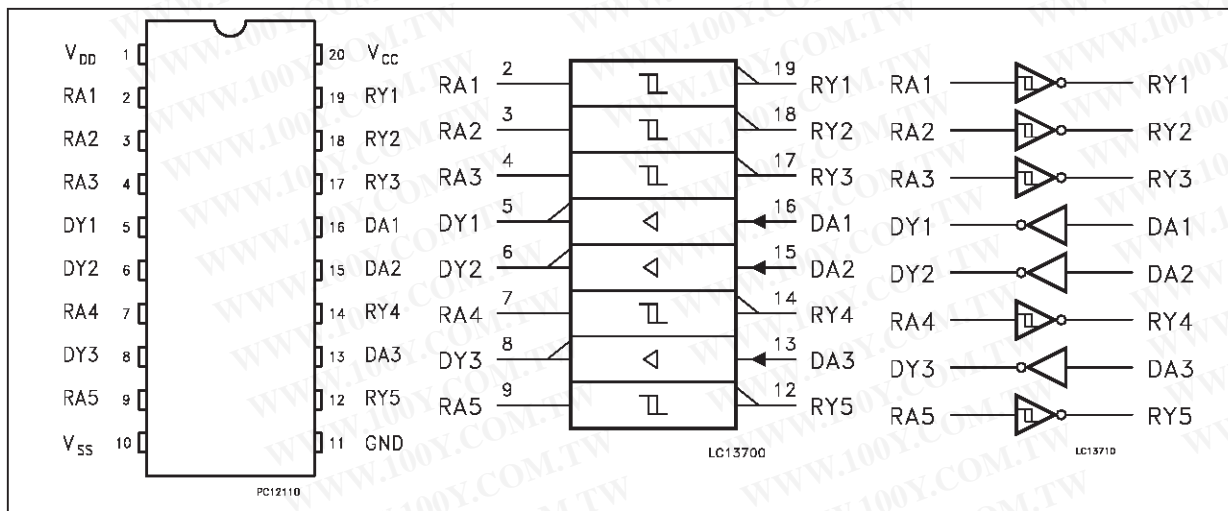

ST75185

勝特力材料 886-3-5753170
勝特力电子(上海) 86-21-54151736
勝特力电子(深圳) 86-755-83298787
[Http://www.100y.com.tw](http://www.100y.com.tw)

ORDER CODES

Type	Temperature Range	Package	Comments
ST75185CN	0 to 70 °C	DIP-20	20 parts per tube / 50 tubes per box
ST75185CD	0 to 70 °C	SO-20 (Tube)	40 parts per tube / 25 tubes per box
ST75185CDR	0 to 70 °C	SO-20 (Tape & Reel)	1000 parts per reel

PIN DESCRIPTION

PIN No	SYMBOL	NAME AND FUNCTION
1	V _{DD}	Supply Voltage (+12V)
2	RA1	First Receiver Input
3	RA2	Second Receiver Input
4	RA3	Third Receiver Input
5	DY1	First Driver Output
6	DY2	Second Driver Output
7	RA4	Fourth Receiver Input
8	DY3	Third Driver Output
9	RA5	Fifth Receiver Input
10	V _{SS}	Supply Voltage (-12V)
11	GND	Ground
12	RY5	Fifth Receiver Output
13	DA3	Third Driver Input
14	RY4	Fourth Receiver Output
15	DA2	Second Driver Input
16	DA1	First Driver Input
17	RY3	Third Receiver Output
18	RY2	Second Receiver Output
19	RY1	First Receiver Output
20	V _{CC}	Supply Voltage (+5V)



ABSOLUTE MAXIMUM RATINGS OVER OPERATING FREE-AIR TEMPERATURE RANGE
(unless otherwise specified)

Symbol	Parameter	Value	Unit
V _{DD}	Supply Voltage (Note 1)	15	V
V _{SS}	Supply Voltage (Note 1)	-15	V
V _{CC}	Supply Voltage (Note 1)	10	V
V _I	Input Voltage Range (DRIVER)	-15 to 7	V
V _I	Input Voltage Range (RECEIVER)	-30 to 30	V
V _O	Output Voltage Range (DRIVER)	-15 to 15	V
I _O	Receiver Low Level Output Current	20	mA
P _D	Continuous Total Power Dissipation	See Dissipation Rating Table	
T _A	Operating Free-Air Temperature Range	0 to 70	°C
T _{stg}	Storage Temperature Range	-65 to +150	°C
T _L	Lead Temperature 1.6mm from case for 10 sec	260	°C

Absolute Maximum Ratings are those values beyond which damage to the device may occur. Functional operation under these condition is not implied.
NOTE1: All voltage are with respect to the network ground terminal.

DISSIPATION RATING TABLE

Package	Power Rating at T _A ≤ 25 °C	Derating Factor above T _A = 25 °C (*)	Power Rating at T _A ≤ 70 °C
MICROPACKAGE (D)	1125 mW	9.0 mW/°C	720 mW
DIP (N)	1150 mW	9.2 mW/°C	736 mW

(*) This is the reverse of the traditional junction-case thermal resistance R_{jc}

RECOMMENDED OPERATING CONDITIONS

Symbol	Parameter	Min	Max	Unit
V _{DD}	Supply Voltage	7.5	15	V
V _{SS}	Supply Voltage	-7.5	-15	V
V _{CC}	Supply Voltage	4.5	5.5	V
V _{IN}	Driver Input Voltage	0	V _{CC}	V
I _{OH}	High Level Output Current	DRIVER	-6	mA
		RECEIVER	-0.5	
I _{OL}	Low Level Output Current	DRIVER	6	mA
		RECEIVER	16	
T _A	Operating Free-Air Temperature	0	70	°C

SUPPLY CURRENTS

Symbol	Parameter	Test Conditions			Value			Unit
		V _{DD}	V _{SS}		Min.	Typ.	Max.	
I _{DD}	Supply Current from V _{DD}	9	-9	No load. All inputs at 1.9V			15	mA
		12	-12				19	
		15	-15				25	
		9	-9	No load. All inputs at 0.8V			4.5	mA
		12	-12				5.5	
		15	-15				9	
I _{SS}	Supply Current from V _{SS}	9	-9	No load. All inputs at 1.9V			-15	mA
		12	-12				-19	
		15	-15				-25	
		9	-9	No load. All inputs at 0.8V			-3.2	mA
		12	-12				-3.2	
		15	-15				-3.2	
I _{CC}	Supply Current from V _{CC}	No load. All inputs at 5V V _{CC} = 5V					30	mA

DRIVER ELECTRICAL CHARACTERISTICS OVER OPERATING FREE-AIR TEMPERATURE RANGE (V_{DD} = 9V, V_{SS} = -9V, V_{CC} = 5V, unless otherwise specified)

Symbol	Parameter	Test Conditions	Value			Unit
			Min.	Typ.	Max.	
V _{OH}	High Level Output Voltage	V _{IL} = 0.8 V R _L = 3KΩ (See Figure 1)	6	7.5		V
V _{OL}	Low Level Output Voltage (Note 3)	V _{IH} = 1.9 V R _L = 3KΩ (See Figure 1)		-7.5	-6	V
I _{IH}	High Level Input Current	V _I = 5 V (See Figure 2)			10	μA
I _{IL}	Low Level Input Current	V _I = 0 V (See Figure 2)			-1.6	mA
I _{OS(H)}	High Level Short Circuit Output Current (Note 4)	V _{IL} = 0.8 V V _O = 0 V (See Figure 1)	-4.5	-12	-19.5	mA
I _{OS(L)}	Low Level Short Circuit Output Current	V _{IH} = 2 V V _O = 0 V (See Figure 1)	4.5	12	19.5	mA
R _O	Output Resistance	V _{DD} = V _{SS} = V _{CC} = 0 V V _O = -2 to 2 V (Note 5)	300			Ω

NOTE 3: The algebraic convention, where the more positive (less negative) limit is designated as maximum, is used in this datasheet for logic levels only (e.g. if -10V is a maximum, the typical value is a more negative voltage).

NOTE 4: Output short circuit conditions must maintain the total power dissipation below absolute maximum ratings.

NOTE 5: Test conditions are those specified by EIA-232-E and as listed above.

DRIVER SWITCHING CHARACTERISTICS

($V_{DD} = 12V$, $V_{SS} = -12V$, $V_{CC} = 5V$ $T_A = 25^\circ C$)

Symbol	Parameter	Test Conditions	Value			Unit
			Min.	Typ.	Max.	
t_{PLH}	Propagation Delay Time, Low to High Level Output	$R_L = 3$ to $7\text{ K}\Omega$ $C_L = 15\text{ pF}$ (See Figures 3, 4)		315	500	ns
t_{PHL}	Propagation Delay Time High to Low Level Output	$R_L = 3$ to $7\text{ K}\Omega$ $C_L = 15\text{ pF}$ (See Figures 3, 4)		75	175	ns
t_{TLH}	Transition Time Low to High Level Output	$R_L = 3$ to $7\text{ K}\Omega$ $C_L = 15\text{ pF}$ (See Figures 3, 4)		60	100	ns
		$R_L = 3$ to $7\text{ K}\Omega$ $C_L = 2500\text{ pF}$ (Note 6, See Figure 3, 4)		1.7	2.5	μs
t_{THL}	Transition Time High to Low Level Output	$R_L = 3$ to $7\text{ K}\Omega$ $C_L = 15\text{ pF}$ (See Figure 3, 4)		40	7.5	ns
		$R_L = 3$ to $7\text{ K}\Omega$ $C_L = 2500\text{ pF}$ (Note 6, See Figure 3, 4)		1.5	2.5	μs

NOTE6: Measured between -3V and 3V points of output waveform (EIA-232-E conditions), all unused inputs are tied.

RECEIVER ELECTRICAL CHARACTERISTICS OVER OPERATING CONDITIONS

Symbol	Parameter	Test Conditions	Value			Unit
			Min.	Typ.	Max.	
V_{T+}	Positive Going Threshold Voltage	(See Figure 6)		2.2	2.4	V
V_{T-}	Negative Going Threshold Voltage	$T_A = 25^\circ C$ (See Figure 6)	0.75	0.97		V
V_{hys}	Input Hysteresis ($V_{T+} - V_{T-}$)		0.5			V
V_{OH}	High Level Output Voltage	$I_{OH} = -0.5\text{ mA}$ $V_{IH} = 0.75\text{ V}$	2.6	4	5	V
		Inputs Open	2.6			
V_{OL}	Low Level Output Voltage	$V_I = 3\text{ V}$ $I_{OL} = 10\text{ mA}$		0.2	0.45	V
I_{IH}	High Level Input Current	$V_I = 25\text{ V}$ (See Figure 6)	3.6		8.3	mA
		$V_I = 3\text{ V}$ (See Figure 6)	0.43			
I_{IL}	Low Level Input Current	$V_I = -25\text{ V}$ (See Figure 6)	-3.6		-8.3	mA
		$V_I = -3\text{ V}$ (See Figure 6)	-0.43			
I_{OS}	Short-Circuit Output Current	$V_I = 0\text{ V}$ $V_O = 0\text{ V}$ (See Figure 5)		-3.4	-12	mA

All typical values are at $T_A = 25^\circ C$, $V_{CC} = 5V$, $V_{DD} = 9V$ and $V_{SS} = -9V$

RECEIVER SWITCHING CHARACTERISTICS

($V_{DD} = 12V$, $V_{SS} = -12V$, $V_{CC} = 5V$ $T_A = 25^\circ C$)

Symbol	Parameter	Test Conditions	Value			Unit
			Min.	Typ.	Max.	
t_{PLH}	Propagation Delay Time, Low to High Level Output	$R_L = 5\text{ K}\Omega$ $C_L = 50\text{ pF}$ (See Figure 6)		400	1000	ns
t_{PHL}	Propagation Delay Time High to Low Level Output	$R_L = 5\text{ K}\Omega$ $C_L = 50\text{ pF}$ (See Figure 6)		70	150	ns
t_{TLH}	Transition Time Low to High Level Output	$R_L = 5\text{ K}\Omega$ $C_L = 50\text{ pF}$ (See Figure 6)		200	525	ns
t_{THL}	Transition Time High to Low Level Output	$R_L = 5\text{ K}\Omega$ $C_L = 50\text{ pF}$ (See Figure 6)		20	60	ns

APPLICATION CIRCUITS

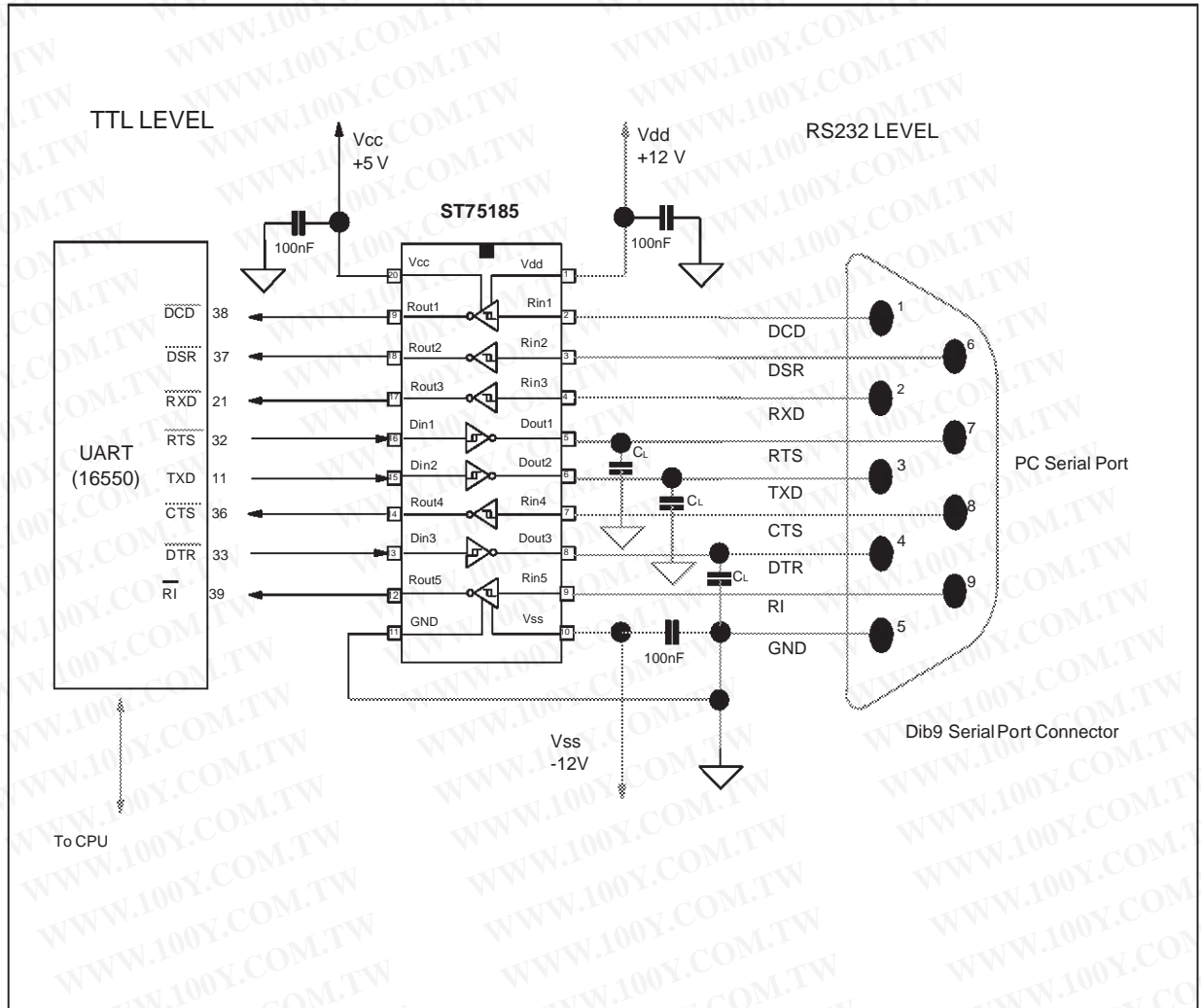

FIGURE 1: Driver Test Circuit for V_{OH} , V_{OL} , $I_{SO(H)}$ and $I_{SO(L)}$

FIGURE 2: Driver Test Circuit for I_{IH} and I_{IL}

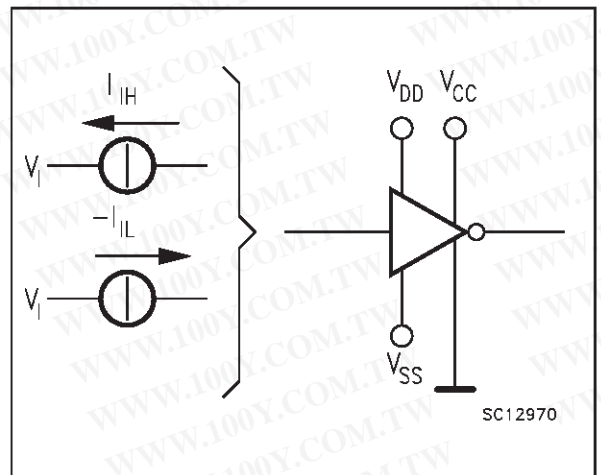
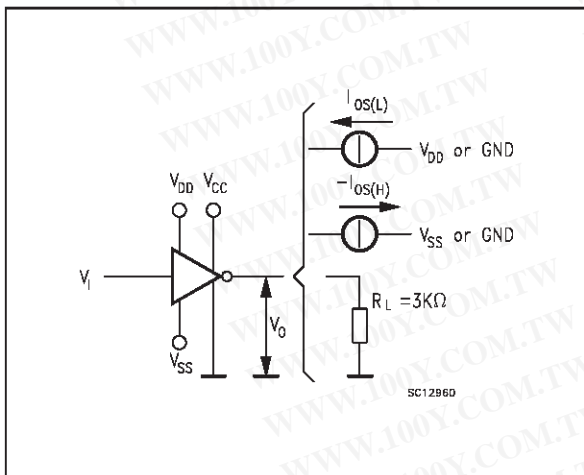

FIGURE 3: Driver Test Circuit

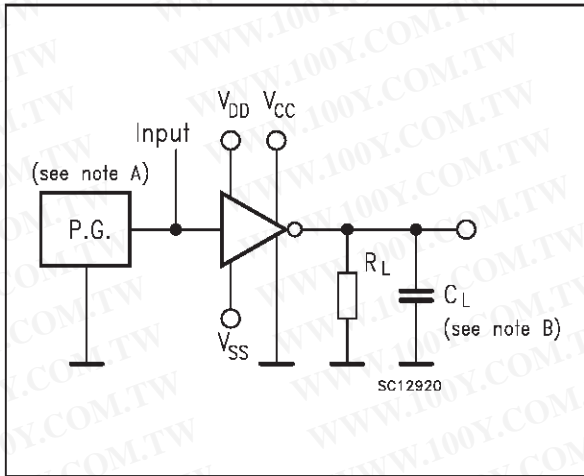

FIGURE 4: Driver Voltage Waveforms

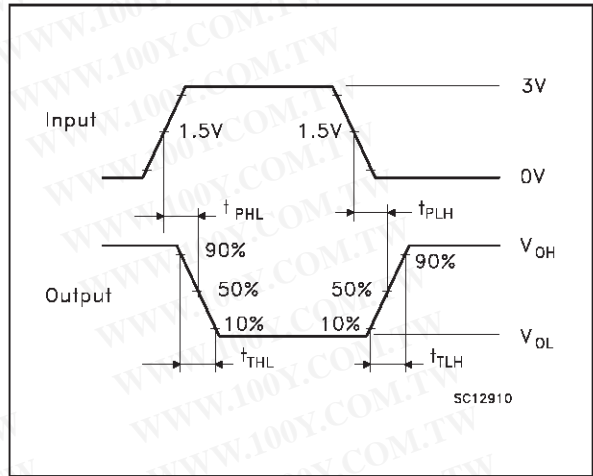

FIGURE 5: Receiver Test Circuit for I_{OS}

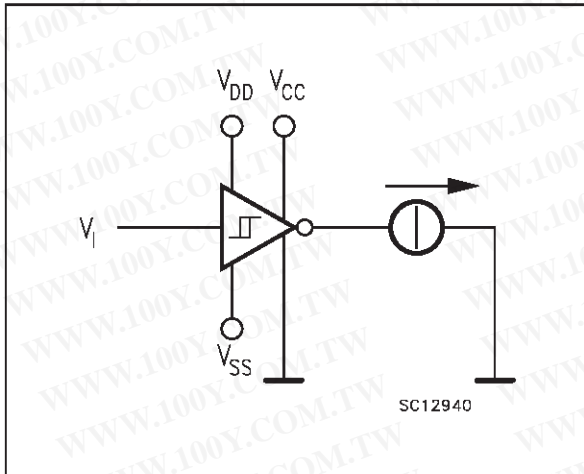

FIGURE 6: Receiver Test Circuit for V_T , V_{OH} , V_{OL}

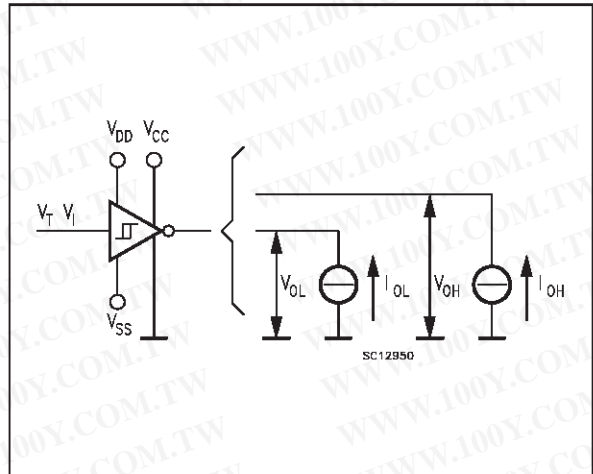

FIGURE 7: Receiver Test Circuit

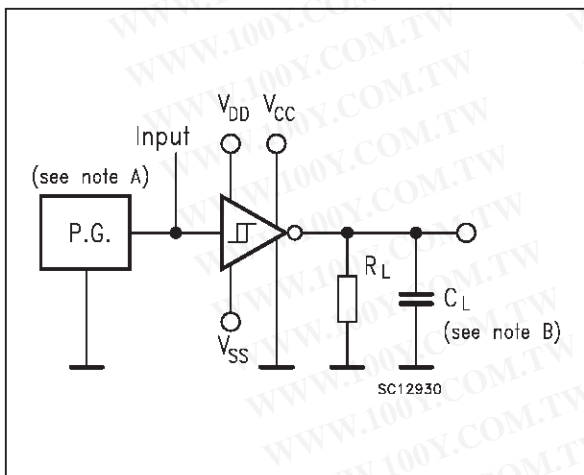
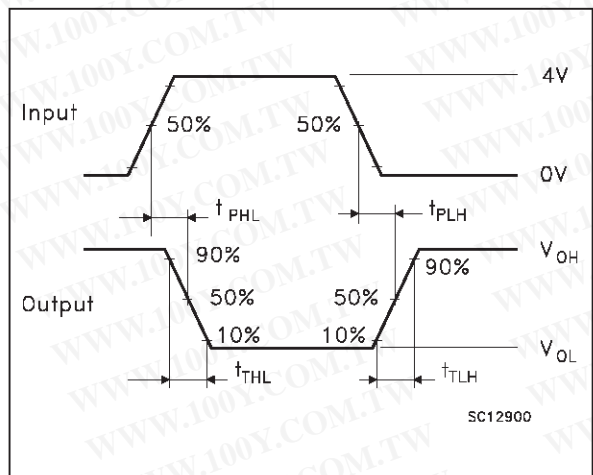

FIGURE 8: Receiver Voltage Waveforms



NOTE A: The pulse generator has the following characteristics: $t_w = 25 \mu s$, $PRR = 20 KHz$, $Z_o = 50 \Omega$, $t_r = t_f < 50ns$.
 NOTE B: C_L includes probe and jig capacitance.

ST75185

Driver Voltage Transfer Characteristics

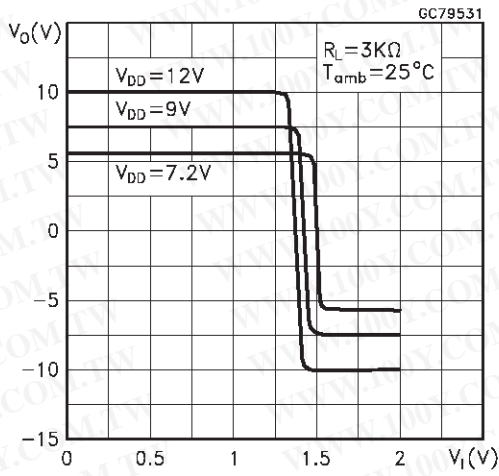

Driver Output Current vs Output Voltage

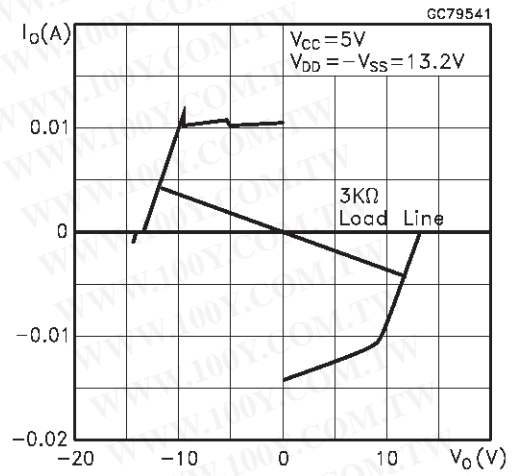

Driver Short Circuit Output Current vs Free-Air Temperature

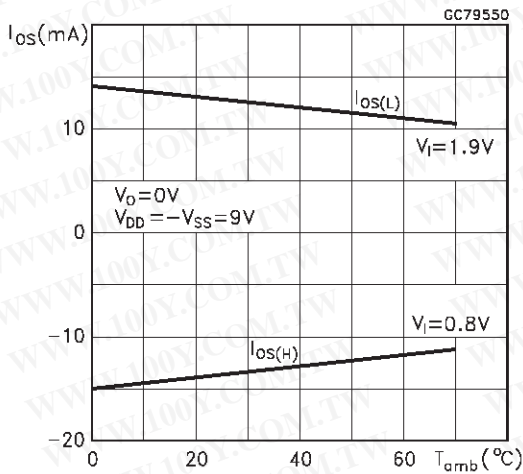

Driver Output Slew Rate vs Load Capacitance

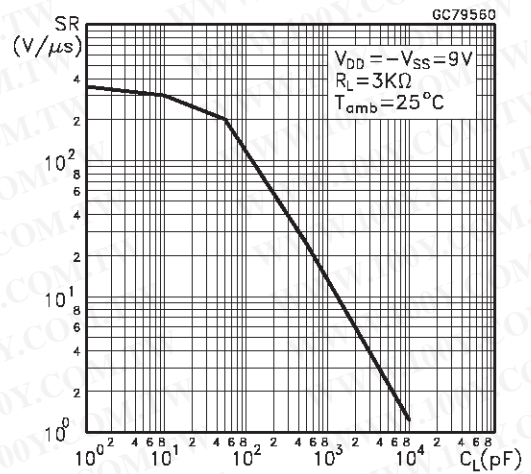

Device Supply Current vs Temperature

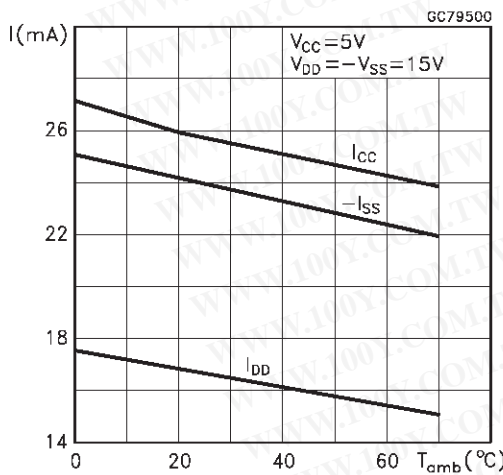

Receiver Threshold vs Temperature

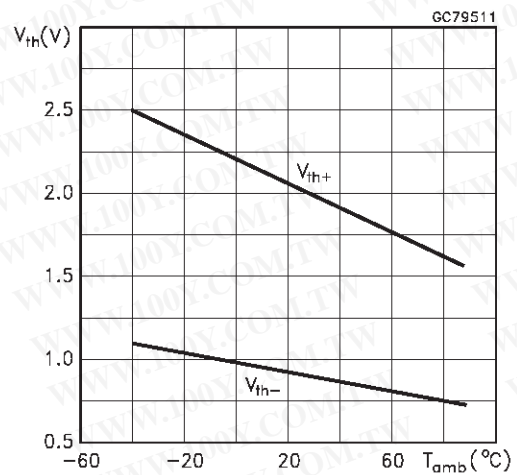

Receiver Threshold vs Supply Voltage

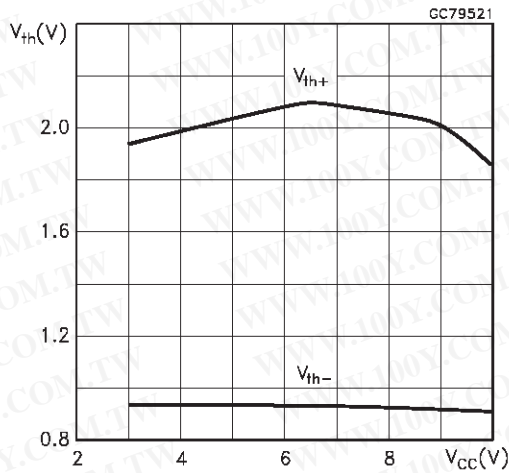

APPLICATION INFORMATION: DIODES ON POWER SUPPLY

Diodes placed in series with the V_{DD} and V_{SS} leads protect the ST75185 in the fault condition in which the devices output are shorted to ±15V and the power supplies are at low state and provide low-impedance path to ground (see Figure below)

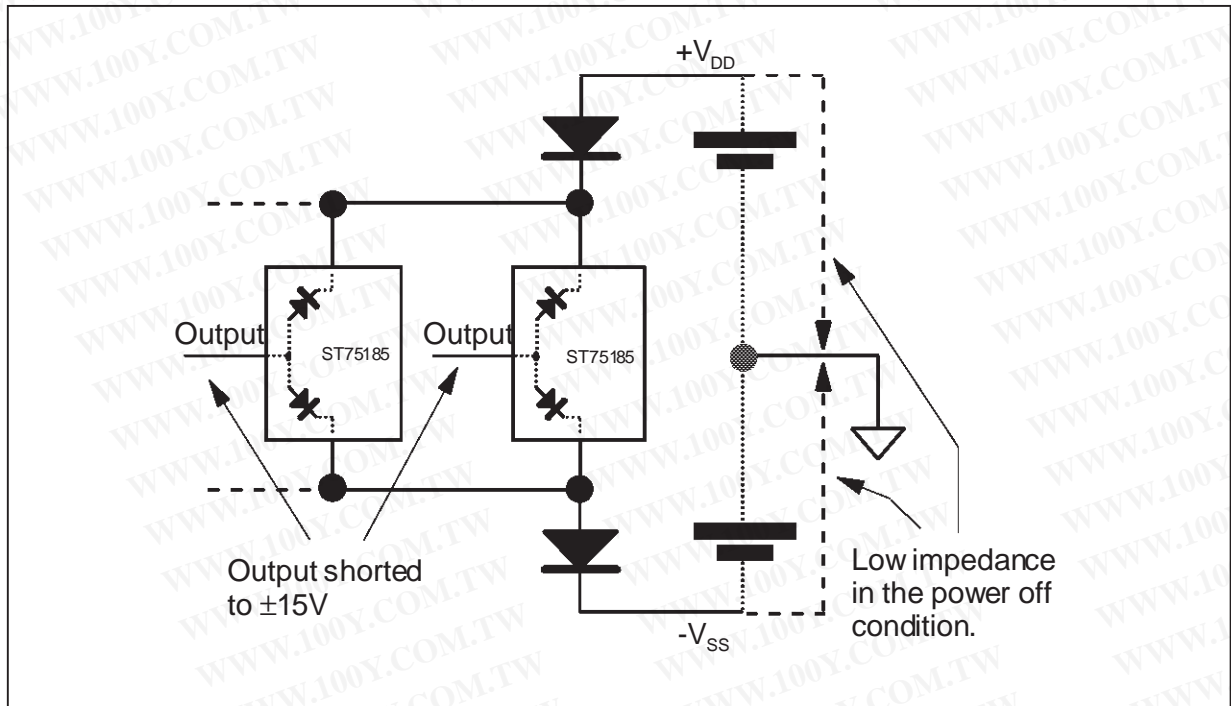

勝特力材料 886-3-5753170
 勝特力电子(上海) 86-21-54151736
 勝特力电子(深圳) 86-755-83298787
[Http://www.100y.com.tw](http://www.100y.com.tw)

ST75185

Plastic DIP-20 (0.25) MECHANICAL DATA

DIM.	mm			inch		
	MIN.	TYP.	MAX.	MIN.	TYP.	MAX.
a1	0.254			0.010		
B	1.39		1.65	0.055		0.065
b		0.45			0.018	
b1		0.25			0.010	
D			25.4			1.000
E		8.5			0.335	
e		2.54			0.100	
e3		22.86			0.900	
F			7.1			0.280
l			3.93			0.155
L		3.3			0.130	
Z			1.34			0.053

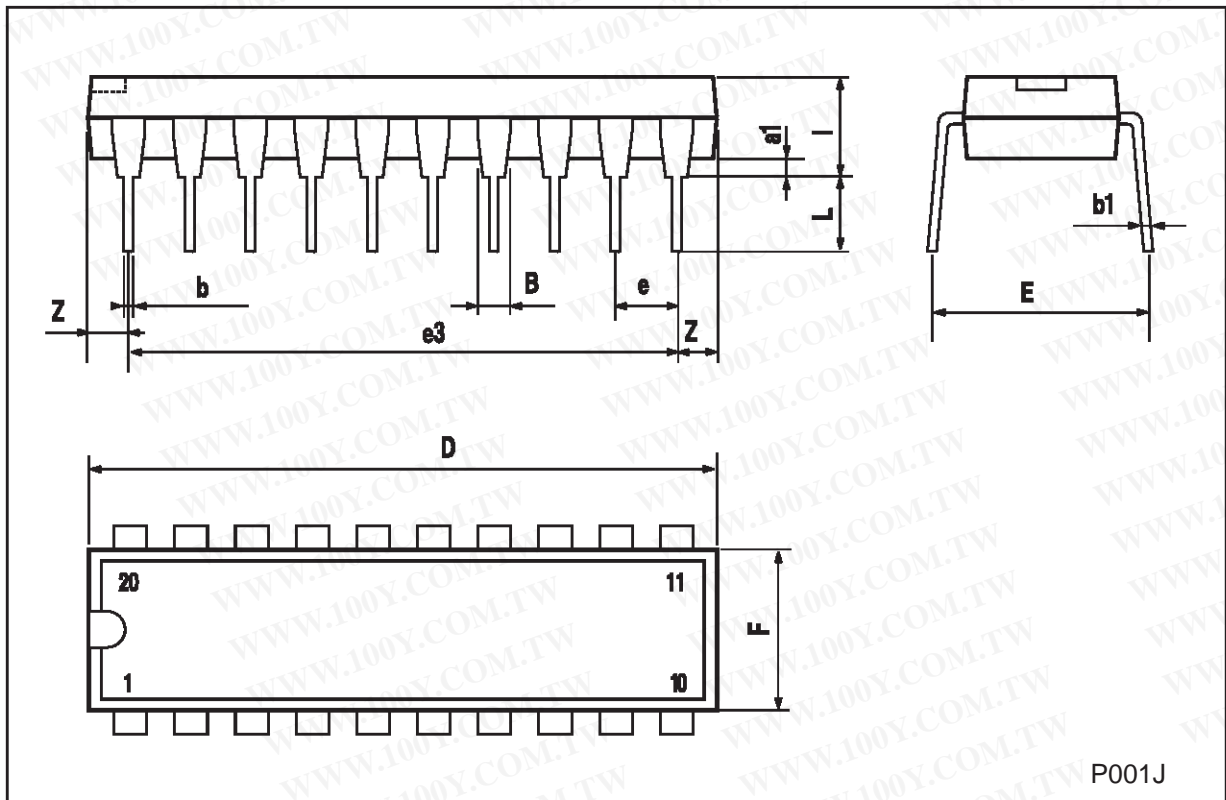

SO-20 MECHANICAL DATA

DIM.	mm			inch		
	MIN.	TYP.	MAX.	MIN.	TYP.	MAX.
A			2.65			0.104
a1	0.10		0.20	0.004		0.007
a2			2.45			0.096
b	0.35		0.49	0.013		0.019
b1	0.23		0.32	0.009		0.012
C		0.50			0.020	
c1	45 (typ.)					
D	12.60		13.00	0.496		0.512
E	10.00		10.65	0.393		0.419
e		1.27			0.050	
e3		11.43			0.450	
F	7.40		7.60	0.291		0.299
L	0.50		1.27	0.19		0.050
M			0.75			0.029
S	8 (max.)					

