

# SN54279, SN54LS279A, SN74279, SN74LS279A QUADRUPLE S-R LATCHES

SDLS093 – DECEMBER 1983 – REVISED MARCH 1988

- Package Options Include Plastic "Small Outline" Packages, Ceramic Chip Carriers and Flat Packages, and Plastic and Ceramic DIPs

- Dependable Texas Instruments Quality and Reliability description

The '279 offers 4 basic  $\bar{S}$ - $\bar{R}$  flip-flop latches in one 16-pin, 300-mil package. Under conventional operation, the  $\bar{S}$ - $\bar{R}$  inputs are normally held high. When the  $\bar{S}$  input is pulsed low, the Q output will be set high. When  $\bar{R}$  is pulsed low, the Q output will be reset low. Normally, the  $\bar{S}$ - $\bar{R}$  inputs should not be taken low simultaneously. The Q output will be unpredictable in this condition.

**FUNCTION TABLE**  
(each latch)

INPUTS		OUTPUT
$\bar{S}$	$\bar{R}$	Q
H	H	$Q_0$
L	H	H
H	L	L
L	L	$H^\ddagger$

H = high level      L = low level

$^\dagger$  For latches with double S inputs:

$Q_0$  = the level of Q before the indicated input conditions were established.

$^\ddagger$  This configuration is nonstable: that is, it may not persist when the  $\bar{S}$  and  $\bar{R}$  inputs return to their inactive (high) level.

H = both  $\bar{S}$  inputs high

L = one or both  $\bar{S}$  inputs low

### logic diagram (positive logic)

(latches 1 and 3)

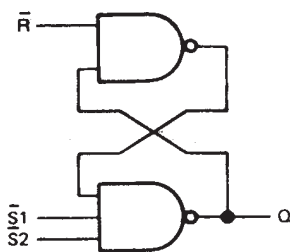

(latches 2 and 4)

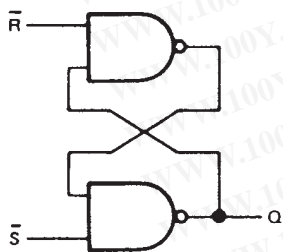

SN54279, SN54LS279A . . . J OR W PACKAGE  
SN74279 . . . N PACKAGE  
SN74LS279A . . . D OR N PACKAGE  
(TOP VIEW)

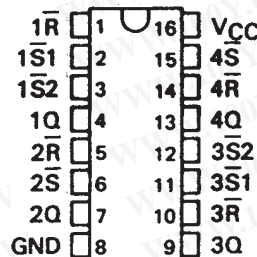

SN54LS279A . . . FK PACKAGE  
(TOP VIEW)

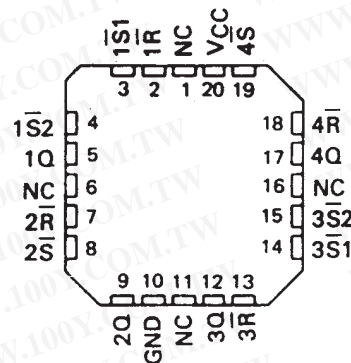

NC - No internal connection

### logic symbol<sup>§</sup>

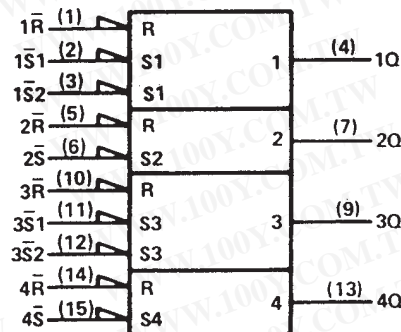

<sup>§</sup>This symbol is in accordance with ANSI/IEEE Std. 91-1984 and IEC Publication 617-12.

Pin numbers shown are for D, J, N, and W packages.

勝特力材料 886-3-5753170  
 勝特力电子(上海) 86-21-54151736  
 勝特力电子(深圳) 86-755-83298787  
[Http://www.100y.com.tw](http://www.100y.com.tw)

PRODUCTION DATA information is current as of publication date. Products conform to specifications per the terms of Texas Instruments standard warranty. Production processing does not necessarily include testing of all parameters.



Copyright © 1988, Texas Instruments Incorporated



# SN54279, SN54LS279A, SN74279, SN74LS279A QUADRUPLE S-R LATCHES

SDLS093 – DECEMBER 1983 – REVISED MARCH 1988

## recommended operating conditions

	SN54279			SN74279			UNIT
	MIN	NOM	MAX	MIN	NOM	MAX	
V <sub>CC</sub> Supply voltage	4.5	5	5.5	4.75	5	5.25	V
V <sub>IH</sub> High-level input voltage	2			2			V
V <sub>IL</sub> Low-level input voltage			0.8			0.8	V
I <sub>OH</sub> High-level output current			-0.8			-0.8	mA
I <sub>OL</sub> Low-level output current			16			16	mA
t <sub>w</sub> Pulse duration, low	20			20			ns
T <sub>A</sub> Operating free-air temperature	-55		125	0		70	°C

## electrical characteristics over recommended operating free-air temperature range (unless otherwise noted)

PARAMETER	TEST CONDITIONS <sup>†</sup>	SN54279			SN74279			UNIT
		MIN	TYP <sup>‡</sup>	MAX	MIN	TYP <sup>‡</sup>	MAX	
V <sub>IK</sub>	V <sub>CC</sub> = MIN, I <sub>I</sub> = -12 mA			-1.5			-1.5	V
V <sub>OH</sub>	V <sub>CC</sub> = MIN, V <sub>IL</sub> = 0.8 V, I <sub>OH</sub> = -0.8 mA	2.4	3.4		2.4	3.4		V
V <sub>OL</sub>	V <sub>CC</sub> = MIN, V <sub>IH</sub> = 2 V, I <sub>OL</sub> = 16 mA		0.2	0.4		0.2	0.4	V
I <sub>I</sub>	V <sub>CC</sub> = MAX, V <sub>I</sub> = 5.5 V			1			1	mA
I <sub>IH</sub>	V <sub>CC</sub> = MAX, V <sub>I</sub> = 2.4 V			40			40	μA
I <sub>IL</sub>	V <sub>CC</sub> = MAX, V <sub>I</sub> = 0.4 V			-1.6			-1.6	mA
I <sub>OS</sub> <sup>§</sup>	V <sub>CC</sub> = MAX	-18		-55	-18		-57	mA
I <sub>CC</sub>	V <sub>CC</sub> = MAX, See Note 2		18	30		18	30	mA

<sup>†</sup> For conditions shown as MIN or MAX, use the appropriate value specified under recommended operating conditions.

<sup>‡</sup> All typical values are at V<sub>CC</sub> = 5 V, T<sub>A</sub> = 25°C.

<sup>§</sup> Not more than one output should be shorted at a time.

NOTE 2: I<sub>CC</sub> is measured with all R inputs grounded, all S inputs at 4.5 V, and all outputs open.

## switching characteristics, V<sub>CC</sub> = 5 V, T<sub>A</sub> = 25°C (see note 3)

PARAMETER	FROM (INPUT)	TO (OUTPUT)	TEST CONDITIONS	MIN	TYP	MAX	UNIT
t <sub>PLH</sub>	$\bar{S}$	Q	R <sub>L</sub> = 400 Ω, C <sub>L</sub> = 15 pF		12	22	ns
t <sub>PHL</sub>	$\bar{R}$	Q			9	15	
t <sub>PHL</sub>	$\bar{R}$	Q			15	27	

NOTE 3: Load circuits and voltage waveforms are shown in Section 1.

勝特力材料 886-3-5753170  
 勝特力电子(上海) 86-21-54151736  
 勝特力电子(深圳) 86-755-83298787  
[Http://www.100y.com.tw](http://www.100y.com.tw)

# SN54279, SN54LS279A, SN74279, SN74LS279A QUADRUPLE S-R LATCHES

SDLS093 – DECEMBER 1983 – REVISED MARCH 1988

## recommended operating conditions

	SN54LS279A			SN74LS279A			UNIT
	MIN	NOM	MAX	MIN	NOM	MAX	
V <sub>CC</sub> Supply voltage	4.5	5	5.5	4.75	5	5.25	V
V <sub>IH</sub> High-level input voltage	2			2			V
V <sub>IL</sub> Low-level input voltage			0.7			0.8	V
I <sub>OH</sub> High-level output current			-0.4			-0.4	mA
I <sub>OL</sub> Low-level output current			4			8	mA
t <sub>w</sub> Pulse duration, low	20			20			ns
T <sub>A</sub> Operating free-air temperature	-55		125	0		70	°C

## electrical characteristics over recommended operating free-air temperature range (unless otherwise noted)

PARAMETER	TEST CONDITIONS†	SN54LS279A		SN74LS279A		UNIT		
		MIN	TYP‡	MAX	MIN		TYP‡	MAX
V <sub>IK</sub>	V <sub>CC</sub> = MIN, I <sub>I</sub> = -18 mA			-1.5		-1.5	V	
V <sub>OH</sub>	V <sub>CC</sub> = MIN, V <sub>IL</sub> = MAX, I <sub>OH</sub> = -0.4 mA	2.5	3.4		2.7	3.4	V	
V <sub>OL</sub>	V <sub>CC</sub> = MIN, V <sub>IH</sub> = 2 V, I <sub>OL</sub> = 4 mA		0.25	0.4		0.25	0.4	V
	V <sub>CC</sub> = MIN, V <sub>IH</sub> = 2 V, I <sub>OL</sub> = 8 mA					0.25	0.5	
I <sub>I</sub>	V <sub>CC</sub> = MAX, V <sub>I</sub> = 7 V			0.1		0.1	mA	
I <sub>IH</sub>	V <sub>CC</sub> = MAX, V <sub>I</sub> = 2.7 V			20		20	μA	
I <sub>IL</sub>	V <sub>CC</sub> = MAX, V <sub>I</sub> = 0.4 V			-0.2		-0.2	mA	
I <sub>OS</sub> §	V <sub>CC</sub> = MAX	-20		-100	-20	-100	mA	
I <sub>CC</sub>	V <sub>CC</sub> = MAX, See note 2		3.8	7		3.8	7	mA

† For conditions shown as MIN or MAX, use the appropriate value specified under recommended operating conditions.

‡ All typical values are at V<sub>CC</sub> = 5 V, T<sub>A</sub> = 25°C.

§ Not more than one output should be shorted at a time, and the duration of the short-circuit should be less than one second.

NOTE 2: I<sub>CC</sub> is measured with all R inputs grounded, all S inputs at 4.5 V, and all outputs open.

## switching characteristics, V<sub>CC</sub> = 5 V, T<sub>A</sub> = 25°C (see note 3)

PARAMETER	FROM (INPUT)	TO (OUTPUT)	TEST CONDITIONS	MIN	TYP	MAX	UNIT
t <sub>PLH</sub>	S	Q	R <sub>L</sub> = 2 kΩ, C <sub>L</sub> = 15 pF		12	22	ns
t <sub>PHL</sub>					13	21	
t <sub>PHL</sub>	R	Q			15	27	ns

NOTE 3: Load circuits and voltage waveforms are shown in Section 1.

勝特力材料 886-3-5753170  
 勝特力电子(上海) 86-21-54151736  
 勝特力电子(深圳) 86-755-83298787  
[Http://www.100y.com.tw](http://www.100y.com.tw)