

SN54132, SN54LS132, SN54S132, SN74132, SN74LS132, SN74S132 QUADRUPLE 2-INPUT POSITIVE-NAND SCHMITT TRIGGERS

SDLS047 - DECEMBER 1983 - REVISED MARCH 1988

- Operation from Very Slow Edges
- Improved Line-Receiving Characteristics
- High Noise Immunity

description

Each circuit functions as a 2-input NAND gate, but because of the Schmitt action, it has different input threshold levels for positive (V_{T+}) and for negative going (V_{T-}) signals.

These circuits are temperature-compensated and can be triggered from the slowest of input ramps and still give clear, jitter-free output signals.

The SN54132, SN54LS132, and SN54S132 are characterized for operation over the full military temperature range of -55°C to 125°C . The SN74132, SN74LS132, and SN74S132 are characterized for operation from 0°C to 70°C .

logic diagram (positive logic)

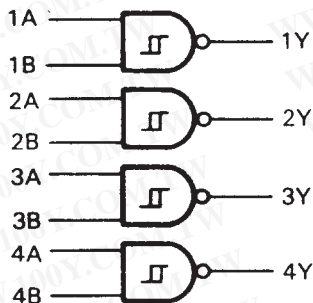

勝特力材料 886-3-5753170
 勝特力电子(上海) 86-21-54151736
 勝特力电子(深圳) 86-755-83298787
[Http://www.100y.com.tw](http://www.100y.com.tw)

SN54132, SN54LS132, SN54S132 . . . J OR W PACKAGE
 SN74132 . . . N PACKAGE
 SN74LS132, SN74S132 . . . D OR N PACKAGE

(TOP VIEW)



SN54LS132, SN54S132 . . . FK PACKAGE

(TOP VIEW)

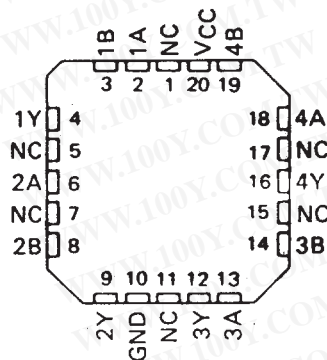

NC-No internal connection

logic symbol†

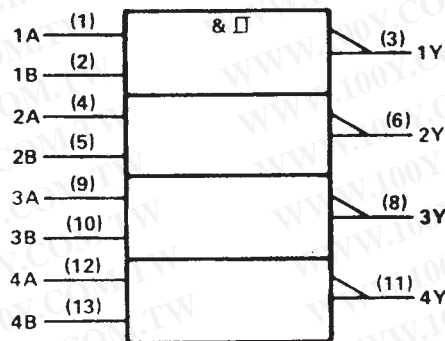

positive logic: $Y = \overline{AB}$ or $Y = \overline{A} + \overline{B}$

†This symbol is in accordance with ANSI/IEEE Std 91-1984 and IEC Publication 617-12. Pin numbers shown are for D, J, N, and W packages.

SN54132, SN54LS132, SN54S132,
 SN74132, SN74LS132, SN74S132
QUADRUPLE 2-INPUT POSITIVE-NAND SCHMITT TRIGGERS

SDLS047 – DECEMBER 1983 – REVISED MARCH 1988

schematics

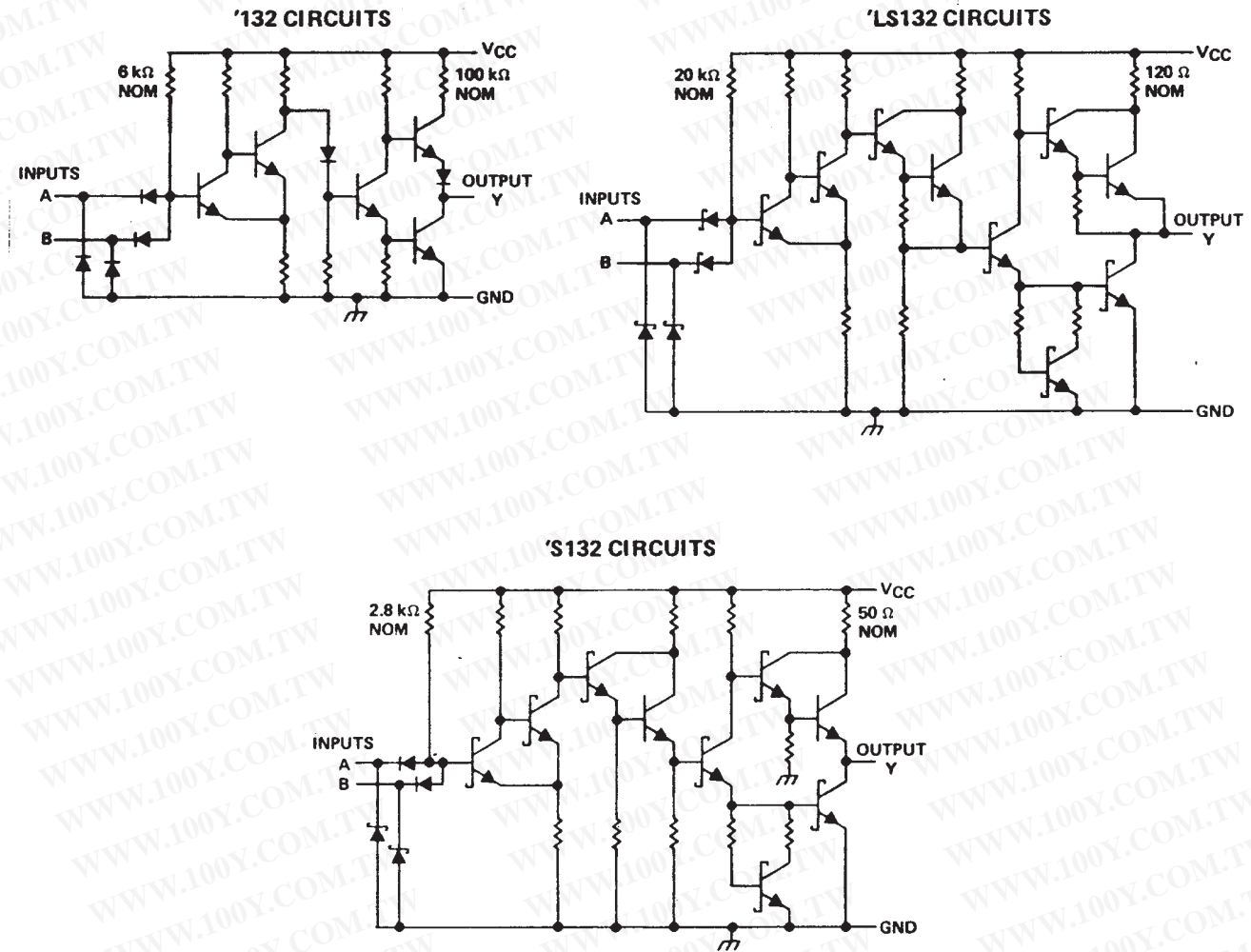

Resistor values shown are nominal.

absolute maximum ratings over operating free-air temperature range (unless otherwise noted)

Supply voltage, V_{CC} (see Note 1)	7 V
Input voltage: '132, 'S132	5.5 V
'LS132	7 V
Operating free-air temperature: SN54'	-55°C to 125°C
SN74'	0°C to 70°C
Storage temperature range	-65°C to 150°C

NOTE 1: Voltages values are with respect to network ground terminal.

勝特力材料 886-3-5753170
 勝特力电子(上海) 86-21-54151736
 勝特力电子(深圳) 86-755-83298787
[Http://www.100y.com.tw](http://www.100y.com.tw)



POST OFFICE BOX 655303 • DALLAS, TEXAS 75265

SN54132, SN74132

QUADRUPLE 2-INPUT POSITIVE-NAND SCHMITT TRIGGERS

SDLS047 – DECEMBER 1983 – REVISED MARCH 1988

recommended operating conditions

	SN54132			SN74132			UNIT
	MIN	NOM	MAX	MIN	NOM	MAX	
V _{CC} Supply voltage	4.5	5	5.5	4.75	5	5.25	V
I _{OH} High-level output current			-0.8			-0.8	mA
I _{OL} Low-level output current			16			16	mA
T _A Operating free-air temperature	-55		125	0		70	°C

electrical characteristics over recommended operating free-air temperature range (unless otherwise noted)

PARAMETER	TEST CONDITIONS†	MIN	TYP‡	MAX	UNIT
V _{T+}	V _{CC} = 5 V	1.5	1.7	2	V
V _{T-}	V _{CC} = 5 V	0.6	0.9	1.1	V
V _{hys} (V _{T+} - V _{T-})	V _{CC} = 5 V	0.4	0.8		V
V _{IK}	V _{CC} = MIN, I _I = -12 mA			-1.5	V
V _{OH}	V _{CC} = MIN, V _I = 0.6 V, I _{OH} = -0.8 mA	2.4	3.4		V
V _{OL}	V _{CC} = MIN, V _I = 2 V, I _{OL} = 16 mA		0.2	0.4	V
I _{T+}	V _{CC} = 5 V, V _I = V _{T+}	-0.43			mA
I _{T-}	V _{CC} = 5 V, V _I = V _{T-}	-0.56			mA
I _I	V _{CC} = MAX, V _I = 5.5 V			1	mA
I _{IH}	V _{CC} = MAX, V _I = 2.4 V			40	μA
I _{IL}	V _{CC} = MAX, V _{IL} = 0.4 V	-0.8		-1.2	mA
I _{OS} §	V _{CC} = MAX	-18		-55	mA
I _{CCH}	V _{CC} = MAX		15	24	mA
I _{CCL}	V _{CC} = MAX		26	40	mA

† For conditions shown as MIN or MAX, use the appropriate value specified under recommended operating conditions.

‡ All typical values are at V_{CC} = 5 V, T_A = 25°C.

§ Not more than one output should be shorted at a time.

switching characteristics, V_{CC} = 5 V, T_A = 25°C (see figure 1)

PARAMETER	FROM (INPUT)	TO (OUTPUT)	TEST CONDITIONS	MIN	TYP	MAX	UNIT
t _{PLH}	Any	Y	R _L = 400 Ω, C _L = 15 pF		15	22	ns
t _{PHL}					15	22	ns

勝特力材料 886-3-5753170
 勝特力电子(上海) 86-21-54151736
 勝特力电子(深圳) 86-755-83298787
[Http://www.100y.com.tw](http://www.100y.com.tw)



SN54LS132, SN74LS132 QUADRUPLE 2-INPUT POSITIVE-NAND SCHMITT TRIGGERS

SDLS047 – DECEMBER 1983 – REVISED MARCH 1988

recommended operating conditions

	SN54LS132			SN74LS132			UNIT
	MIN	NOM	MAX	MIN	NOM	MAX	
V _{CC} Supply voltage	4.5	5	5.5	4.75	5	5.25	V
I _{OH} High-level output current			-0.4			-0.4	mA
I _{OL} Low-level output current			4			8	mA
T _A Operating free-air temperature	-55		125	0		70	°C

electrical characteristics over recommended operating free-air temperature range (unless otherwise noted)

PARAMETER	TEST CONDITIONS†	SN54LS132			SN74LS132			UNIT
		MIN	TYP‡	MAX	MIN	TYP‡	MAX	
V _{T+}	V _{CC} = 5 V	1.4	1.6	1.9	1.4	1.6	1.9	V
V _{T-}	V _{CC} = 5 V	0.5	0.8	1	0.5	0.8	1	V
V _{hys} (V _{T+} - V _{T-})	V _{CC} = 5 V	0.4	0.8		0.4	0.8		V
V _{IK}	V _{CC} = MIN, I _I = -18 mA			-1.5			-1.5	V
V _{OH}	V _{CC} = MIN, V _I = 0.5 V, I _{OH} = -0.4 mA	2.5	3.4		2.7	3.4		V
V _{OL}	V _{CC} = MIN, V _I = 1.9 V	I _{OL} = 4 mA		0.25	0.4	0.25 0.4		V
		I _{OL} = 8 mA				0.35	0.5	
I _{T+}	V _{CC} = 5 V, V _I = V _{T+}	-0.14			-0.14			mA
I _{T-}	V _{CC} = 5 V, V _I = V _{T-}	-0.18			-0.18			mA
I _I	V _{CC} = MAX, V _I = 7 V				0.1			mA
I _{IH}	V _{CC} = MAX, V _I = 2.7 V				20			μA
I _{IL}	V _{CC} = MAX, V _I = 0.4 V				-0.4			mA
I _{OS} §	V _{CC} = MAX	-20		-100	-20		-100	mA
I _{CCH}	V _{CC} = MAX	5.9		11	5.9		11	mA
I _{CCL}	V _{CC} = MAX	8.2		14	8.2		14	mA

† For conditions shown as MIN or MAX, use the appropriate value specified under recommended operating conditions.

‡ All typical values are at V_{CC} = 5 V, T_A = 25° C.

§ Not more than one output should be shorted at a time, and duration of the short-circuit should not exceed one second.

switching characteristics, V_{CC} = 5 V, T_A = 25° C (see figure 1)

PARAMETER	FROM (INPUT)	TO (OUTPUT)	TEST CONDITIONS	MIN	TYP	MAX	UNIT
t _{PLH}	Any	Y	R _L = 2 kΩ, C _L = 15 pF		15	22	ns
t _{PHL}					15	22	ns

勝特力材料 886-3-5753170
 勝特力电子(上海) 86-21-54151736
 勝特力电子(深圳) 86-755-83298787
[Http://www.100y.com.tw](http://www.100y.com.tw)



POST OFFICE BOX 655303 • DALLAS, TEXAS 75265

SN54S132, SN74S132

QUADRUPLE 2-INPUT POSITIVE-NAND SCHMITT TRIGGERS

SDLS047 – DECEMBER 1983 – REVISED MARCH 1988

recommended operating conditions

	SN54S132			SN74S132			UNIT
	MIN	NOM	MAX	MIN	NOM	MAX	
V _{CC} Supply voltage	4.5	5	5.5	4.75	5	5.25	V
I _{OH} High-level output current			-1			-1	mA
I _{OL} Low-level output current			20			20	mA
T _A Operating free-air temperature	-55		125	0		70	°C

electrical characteristics over recommended operating free-air temperature range (unless otherwise noted)

PARAMETER	TEST CONDITIONS†	SN54S132			SN74S132			UNIT
		MIN	TYP‡	MAX	MIN	TYP‡	MAX	
V _{T+}	V _{CC} = 5 V	1.6	1.77	1.9	1.6	1.77	1.9	V
V _{T-}	V _{CC} = 5 V	1.1	1.22	1.4	1.1	1.22	1.4	V
V _{hys} (V _{T+} - V _{T-})	V _{CC} = 5 V	0.2	0.55		0.2	0.55		V
V _{IK}	V _{CC} = MIN, I _I = -18 mA			-1.2			-1.2	V
V _{OH}	V _{CC} = MIN, V _I = 1.1 V, I _{OH} = -1 mA	2.5	3.4		2.7	3.4		V
V _{OL}	V _{CC} = MIN, V _I = 1.9 V, I _{OL} = 20 mA			0.5			0.5	V
I _{T+}	V _{CC} = 5 V, V _I = V _{T+}		-0.9			-0.9		mA
I _{T-}	V _{CC} = 5 V, V _I = V _{T-}		-1.1			-1.1		mA
I _I	V _{CC} = MAX, V _I = 5.5 V			1			1	mA
I _{IH}	V _{CC} = MAX, V _I = 2.7 V			50			50	μA
I _{IL}	V _{CC} = MAX, V _I = 0.5 V			-2			-2	mA
I _{OS} §	V _{CC} = MAX	-40		-100	-40		-100	mA
I _{CCH}	V _{CC} = MAX		28	44		28	44	mA
I _{CCL}	V _{CC} = MAX		44	68		44	68	mA

† For conditions shown as MIN or MAX, use the appropriate value specified under recommended operating conditions.

‡ All typical values are at V_{CC} = 5 V, T_A = 25°C.

§ Not more than one output should be shorted at a time, and duration of the short-circuit should not exceed one second.

switching characteristics, V_{CC} = 5 V, T_A = 25°C (see figure 1)

PARAMETER	FROM (INPUT)	TO (OUTPUT)	TEST CONDITIONS	MIN	TYP	MAX	UNIT
t _{PLH}	A or B	Y	R _L = 280 Ω, C _L = 15 pF		7	10.5	ns
t _{PHL}					8.5	13	

勝特力材料 886-3-5753170
 勝特力电子(上海) 86-21-54151736
 勝特力电子(深圳) 86-755-83298787
[Http://www.100y.com.tw](http://www.100y.com.tw)



SN54132, SN54LS132, SN54S132,
 SN74132, SN74LS132, SN74S132
QUADRUPLE 2-INPUT POSITIVE-NAND SCHMITT TRIGGERS

SDLS047 – DECEMBER 1983 – REVISED MARCH 1988

PARAMETER MEASUREMENT INFORMATION

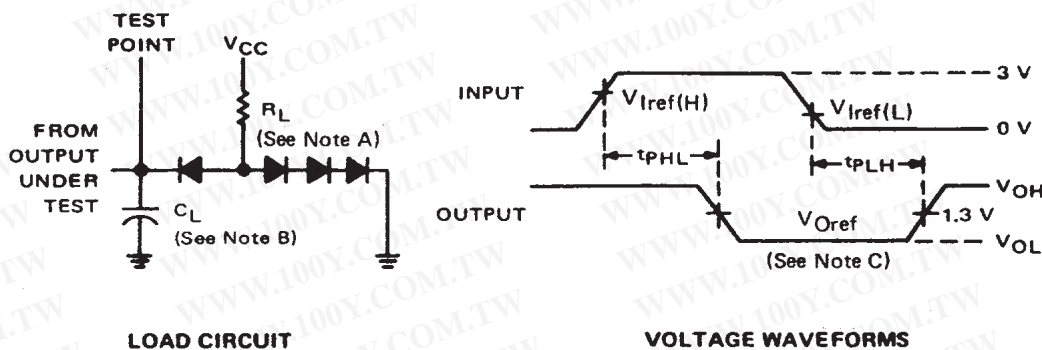

- NOTES: A. All diodes are 1N3064 or equivalent.
 B. C_L includes probe and jig capacitance.
 C. Generator characteristics and reference voltages are:

	Generator Characteristics				Reference Voltages		
	Z_{out}	PRR	t_r	t_f	$V_{I\ ref(H)}$	$V_{I\ ref(L)}$	$V_{O\ ref}$
SN54'/SN74'	50	1 MHz	10 ns	10 ns	1.7 V	0.9 V	1.5 V
SN54LS'/SN74LS'	50	1 MHz	15 ns	6 ns	1.6 V	0.8 V	1.3 V
'S132	50	1 MHz	2.5 ns	2.5 ns	1.8 V	1.2 V	1.5 V

FIGURE 1

勝特力材料 886-3-5753170
 勝特力电子(上海) 86-21-54151736
 勝特力电子(深圳) 86-755-83298787
[Http://www.100y.com.tw](http://www.100y.com.tw)

SN54132, SN74132

QUADRUPLE 2-INPUT POSITIVE-NAND SCHMITT TRIGGERS

SDLS047 – DECEMBER 1983 – REVISED MARCH 1988

TYPICAL CHARACTERISTICS OF '132 CIRCUITS

POSITIVE-GOING THRESHOLD VOLTAGE
vs
FREE-AIR TEMPERATURE

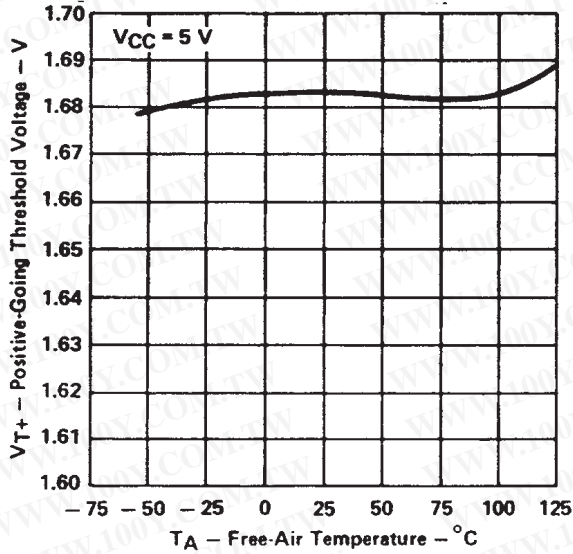

NEGATIVE-GOING THRESHOLD VOLTAGE
vs
FREE-AIR TEMPERATURE

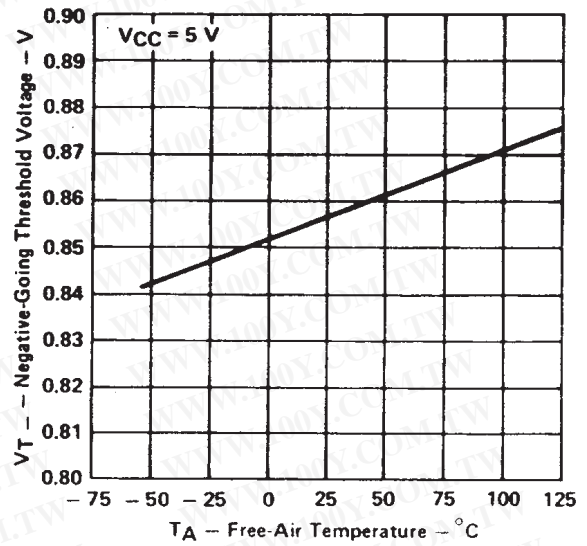

HYSTERESIS
vs
FREE-AIR TEMPERATURE

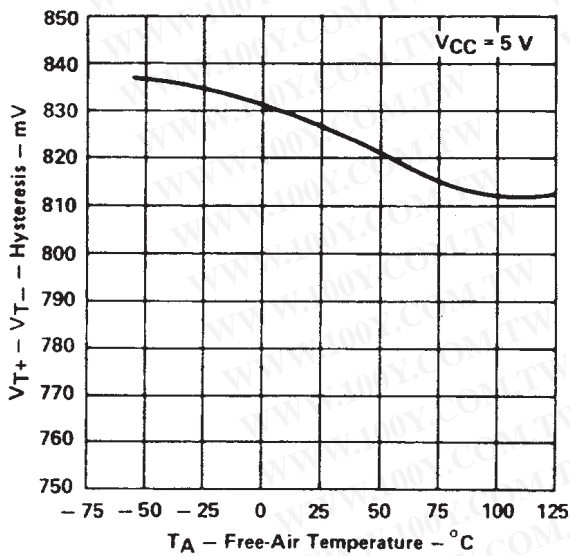

DISTRIBUTION OF UNITS
FOR HYSTERESIS

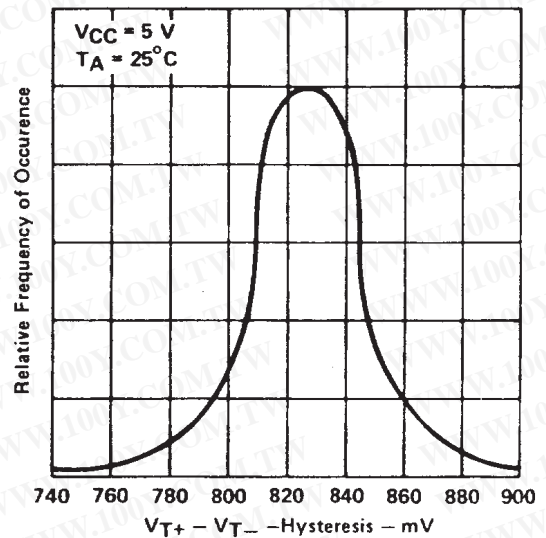

勝特力材料 886-3-5753170
 勝特力电子(上海) 86-21-54151736
 勝特力电子(深圳) 86-755-83298787
[Http://www.100y.com.tw](http://www.100y.com.tw)



SN54132, SN74132 QUADRUPLE 2-INPUT POSITIVE-NAND SCHMITT TRIGGERS

SDLS047 – DECEMBER 1983 – REVISED MARCH 1988

TYPICAL CHARACTERISTICS OF '132 CIRCUITS

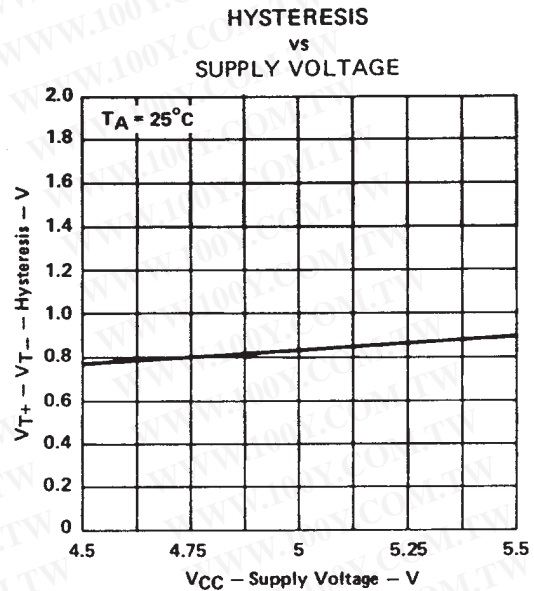
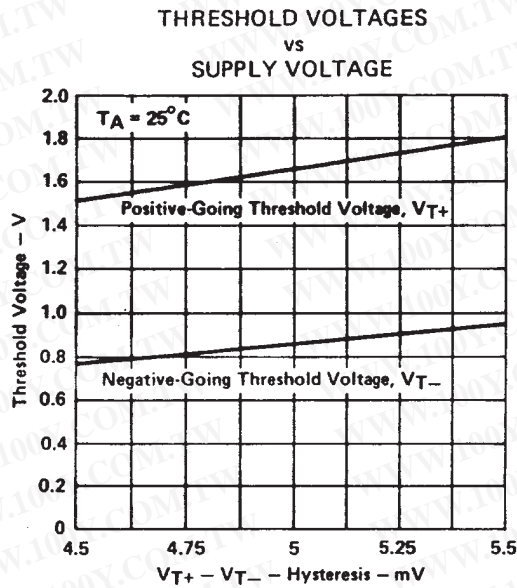

勝特力材料 886-3-5753170
 勝特力电子(上海) 86-21-54151736
 勝特力电子(深圳) 86-755-83298787
[Http://www.100y.com.tw](http://www.100y.com.tw)

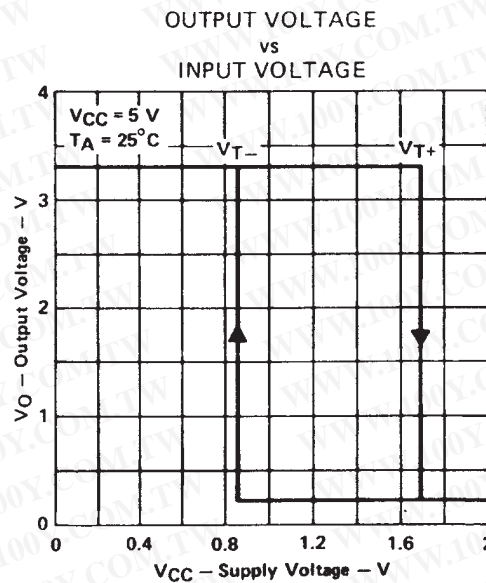

† Data for temperatures below 0°C and 70°C and supply below 4.75 V and above 5.25 V are applicable for SN54132 only.

SN54LS132, SN74LS132

QUADRUPLE 2-INPUT POSITIVE-NAND SCHMITT TRIGGERS

SDLS047 – DECEMBER 1983 – REVISED MARCH 1988

TYPICAL CHARACTERISTICS OF 'LS132 CIRCUITS

POSITIVE-GOING THRESHOLD VOLTAGE
vs
FREE-AIR TEMPERATURE

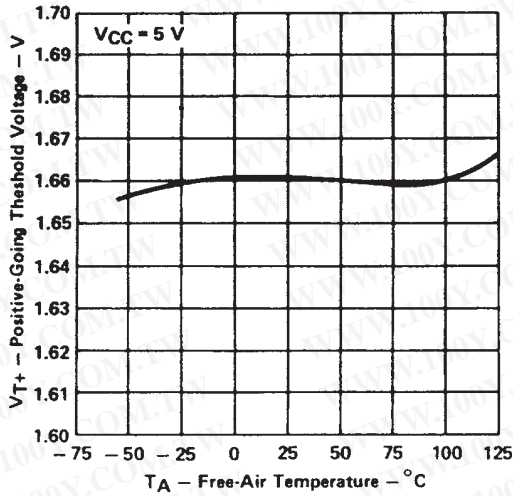

NEGATIVE-GOING THRESHOLD VOLTAGE
vs
FREE-AIR TEMPERATURE

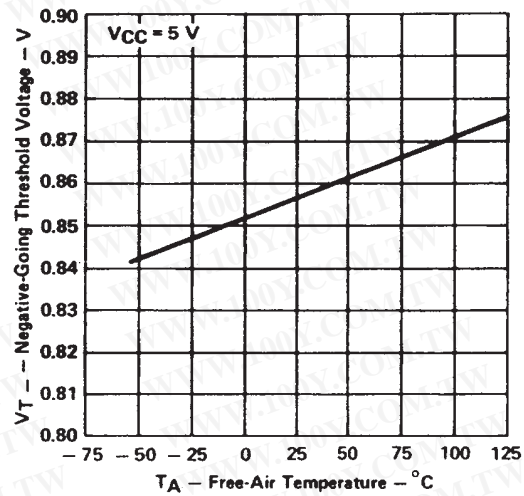

HYSTERESIS
vs
FREE-AIR TEMPERATURE

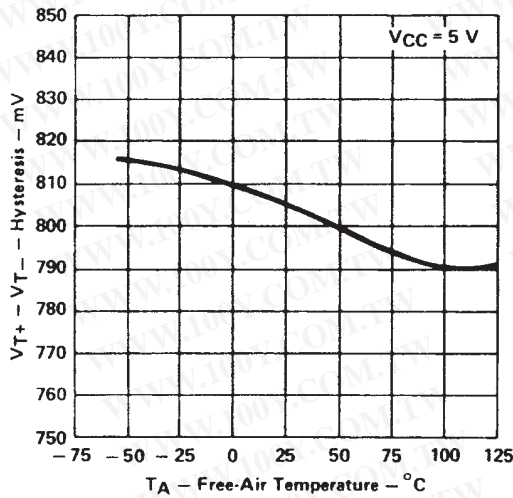

DISTRIBUTION OF UNITS
FOR HYSTERESIS

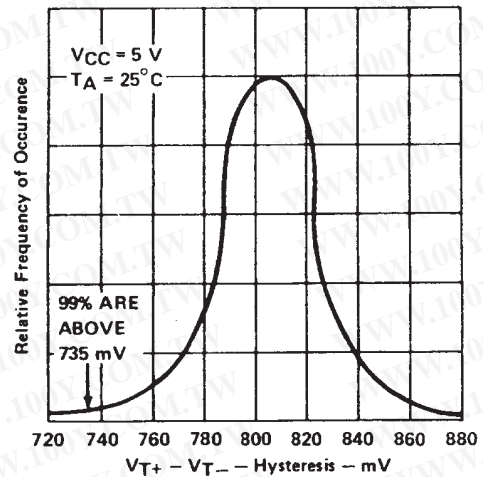

勝特力材料 886-3-5753170
 勝特力电子(上海) 86-21-54151736
 勝特力电子(深圳) 86-755-83298787
[Http://www.100y.com.tw](http://www.100y.com.tw)

Data for temperatures below 0°C and above 70°C and supply voltages below 4.75 V and above 5.25 V are applicable for SN54LS132 only.



POST OFFICE BOX 655303 • DALLAS, TEXAS 75265

SN54LS132, SN74LS132 QUADRUPLE 2-INPUT POSITIVE-NAND SCHMITT TRIGGERS

SDLS047 – DECEMBER 1983 – REVISED MARCH 1988

TYPICAL CHARACTERISTICS OF 'LS132 CIRCUITS

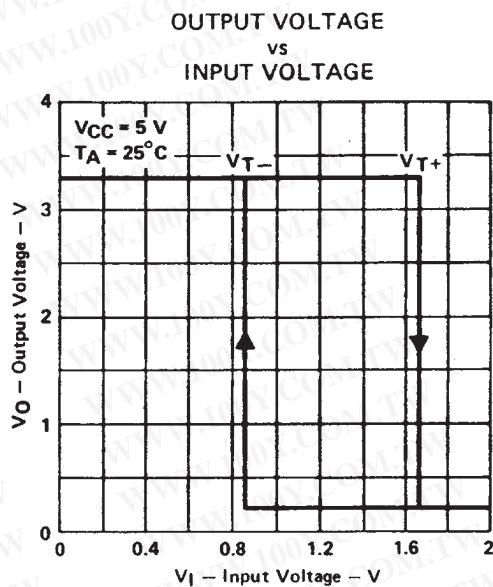
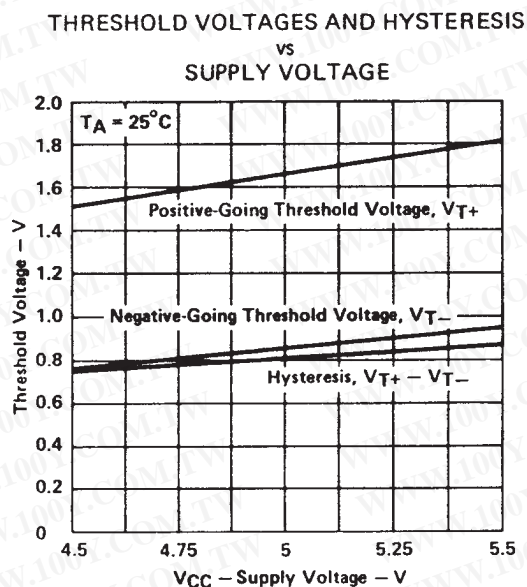

勝特力材料 886-3-5753170
 勝特力电子(上海) 86-21-54151736
 勝特力电子(深圳) 86-755-83298787
[Http://www.100y.com.tw](http://www.100y.com.tw)

† Data for temperatures below 0°C and above 70°C and supply voltages below 4.75 V and above 5.25 V are applicable for SN54LS132 only.

TYPICAL APPLICATION DATA

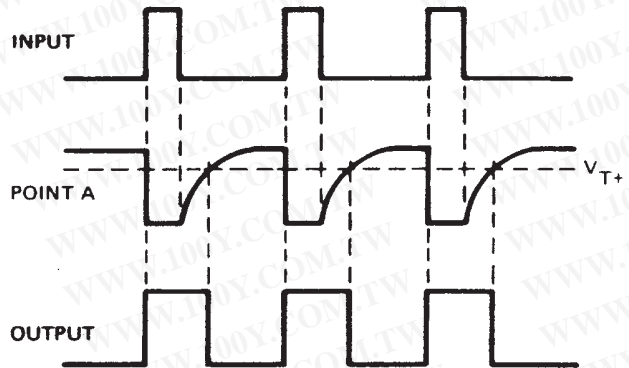
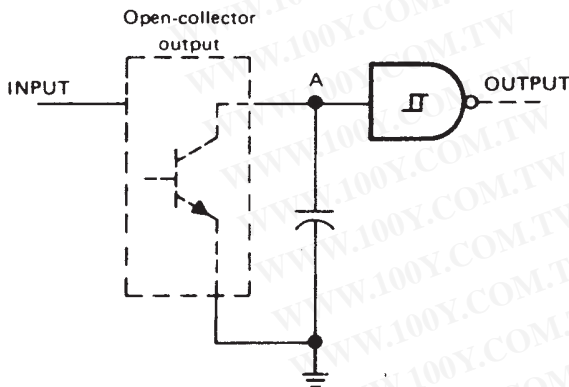
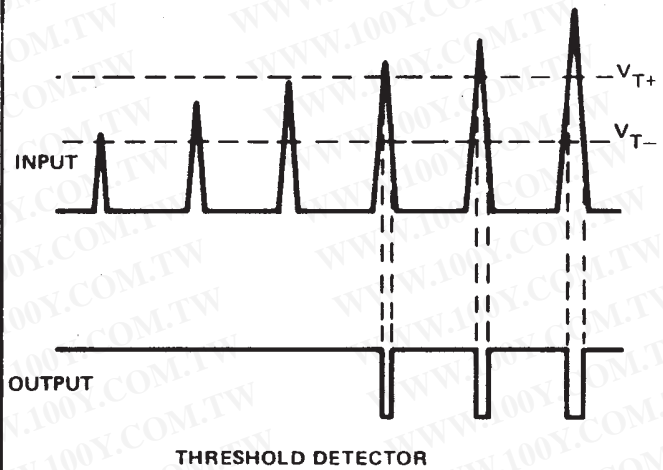
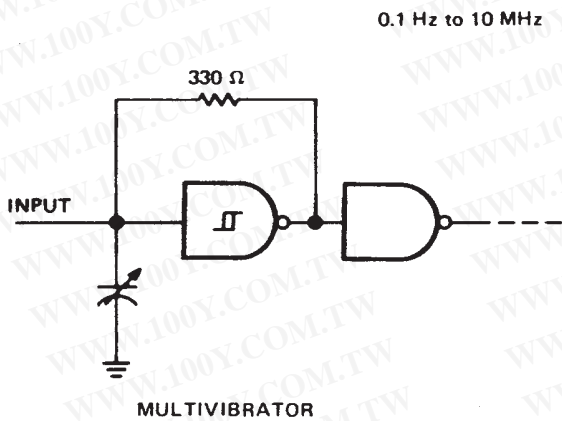
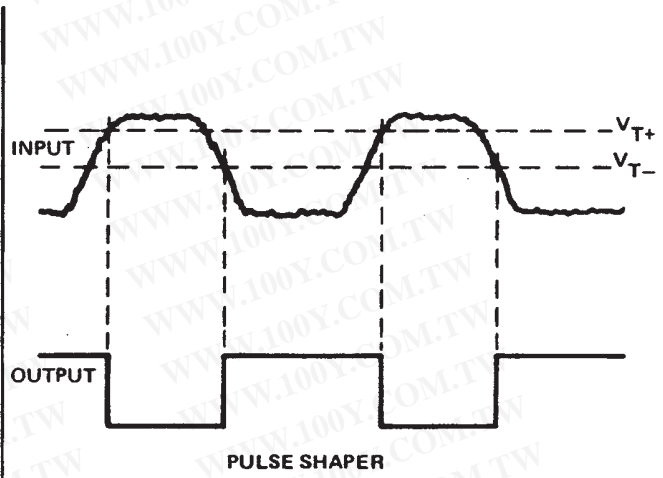
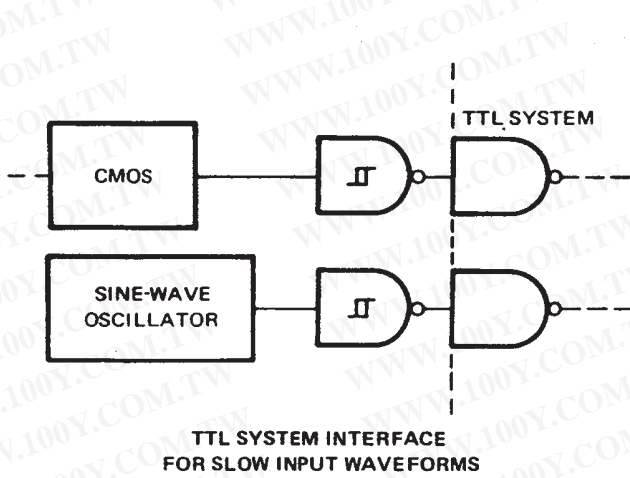

PULSE STRETCHER

IMPORTANT NOTICE

Texas Instruments and its subsidiaries (TI) reserve the right to make changes to their products or to discontinue any product or service without notice, and advise customers to obtain the latest version of relevant information to verify, before placing orders, that information being relied on is current and complete. All products are sold subject to the terms and conditions of sale supplied at the time of order acknowledgement, including those pertaining to warranty, patent infringement, and limitation of liability.

TI warrants performance of its semiconductor products to the specifications applicable at the time of sale in accordance with TI's standard warranty. Testing and other quality control techniques are utilized to the extent TI deems necessary to support this warranty. Specific testing of all parameters of each device is not necessarily performed, except those mandated by government requirements.

CERTAIN APPLICATIONS USING SEMICONDUCTOR PRODUCTS MAY INVOLVE POTENTIAL RISKS OF DEATH, PERSONAL INJURY, OR SEVERE PROPERTY OR ENVIRONMENTAL DAMAGE ("CRITICAL APPLICATIONS"). TI SEMICONDUCTOR PRODUCTS ARE NOT DESIGNED, AUTHORIZED, OR WARRANTED TO BE SUITABLE FOR USE IN LIFE-SUPPORT DEVICES OR SYSTEMS OR OTHER CRITICAL APPLICATIONS. INCLUSION OF TI PRODUCTS IN SUCH APPLICATIONS IS UNDERSTOOD TO BE FULLY AT THE CUSTOMER'S RISK.

In order to minimize risks associated with the customer's applications, adequate design and operating safeguards must be provided by the customer to minimize inherent or procedural hazards.

TI assumes no liability for applications assistance or customer product design. TI does not warrant or represent that any license, either express or implied, is granted under any patent right, copyright, mask work right, or other intellectual property right of TI covering or relating to any combination, machine, or process in which such semiconductor products or services might be or are used. TI's publication of information regarding any third party's products or services does not constitute TI's approval, warranty or endorsement thereof.

勝特力材料 886-3-5753170
勝特力电子(上海) 86-21-54151736
勝特力电子(深圳) 86-755-83298787
[Http://www.100y.com.tw](http://www.100y.com.tw)

Copyright © 1999, Texas Instruments Incorporated