

SN54ALS574B, SN54AS574, SN54AS575 SN74ALS574B, SN74ALS575A, SN74AS574, SN74AS575 OCTAL D-TYPE EDGE-TRIGGERED FLIP-FLOPS WITH 3-STATE OUTPUTS

SDAS165B – JUNE 1982 – REVISED JULY 1995

- 3-State Buffer-Type Noninverting Outputs Drive Bus Lines Directly
- Bus-Structured Pinout
- Buffered Control Inputs
- SN74ALS575A and 'AS575 Have Synchronous Clear
- Package Options Include Plastic Small-Outline (DW) Packages, Ceramic Chip Carriers (FK), Standard Plastic (N, NT) and Ceramic (J, JT) 300-mil DIPs, and Ceramic Flat (W) Packages

description

These octal D-type edge-triggered flip-flops feature 3-state outputs designed specifically for bus driving. They are particularly suitable for implementing buffer registers, I/O ports, bidirectional bus drivers, and working registers.

The eight flip-flops enter data on the low-to-high transition of the clock (CLK) input. The SN74ALS575A, SN54AS575, and SN74AS575 may be synchronously cleared by taking the clear (CLR) input low.

The output-enable (\overline{OE}) input does not affect internal operations of the flip-flops. Old data can be retained or new data can be entered while the outputs are in the high-impedance state.

The SN54ALS574B, SN54AS574, and SN54AS575 are characterized for operation over the full military temperature range of -55°C to 125°C . The SN74ALS574B, SN74ALS575A, SN74AS574, and SN74AS575 are characterized for operation from 0°C to 70°C .

勝特力材料 886-3-5753170
 勝特力电子(上海) 86-21-54151736
 勝特力电子(深圳) 86-755-83298787
[Http://www.100y.com.tw](http://www.100y.com.tw)

SN54ALS574B, SN54AS574 . . . J OR W PACKAGE
SN74ALS574B, SN74AS574 . . . DW OR N PACKAGE
(TOP VIEW)

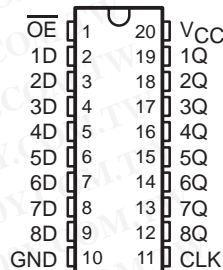

SN54ALS574B, SN54AS574 . . . FK PACKAGE
(TOP VIEW)

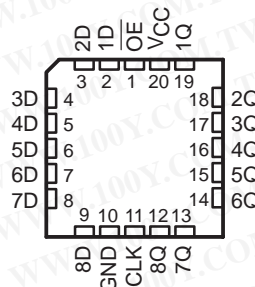

SN54AS575 . . . JT OR W PACKAGE
SN74ALS575A, SN74AS575 . . . DW OR NT PACKAGE
(TOP VIEW)

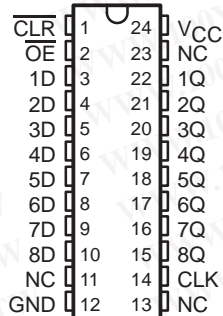

SN54AS575 . . . FK PACKAGE
(TOP VIEW)

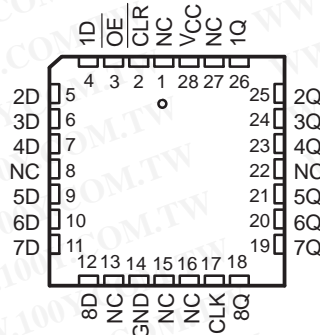

NC – No internal connection

SN54ALS574B, SN54AS574, SN54AS575 SN74ALS574B, SN74ALS575A, SN74AS574, SN74AS575 OCTAL D-TYPE EDGE-TRIGGERED FLIP-FLOPS WITH 3-STATE OUTPUTS

SDAS165B – JUNE 1982 – REVISED JULY 1995

Function Tables

SN54ALS574B, SN74ALS574B, SN54AS574, SN74AS574
(each flip-flop)

| INPUTS | | | OUTPUT |
|-----------------|-----|---|--------|
| \overline{OE} | CLK | D | Q |
| L | ↑ | H | H |
| L | ↑ | L | L |
| L | L | X | Q_0 |
| H | X | X | Z |

SN74ALS575A, SN54AS575, SN74AS575
(each flip-flop)

| INPUTS | | | | OUTPUT |
|-----------------|-----|-----|---|--------|
| \overline{OE} | CLR | CLK | D | Q |
| L | L | ↑ | X | L |
| L | H | ↑ | H | H |
| L | H | ↑ | L | L |
| L | H | L | X | Q_0 |
| H | X | H | X | Z |

logic symbol†

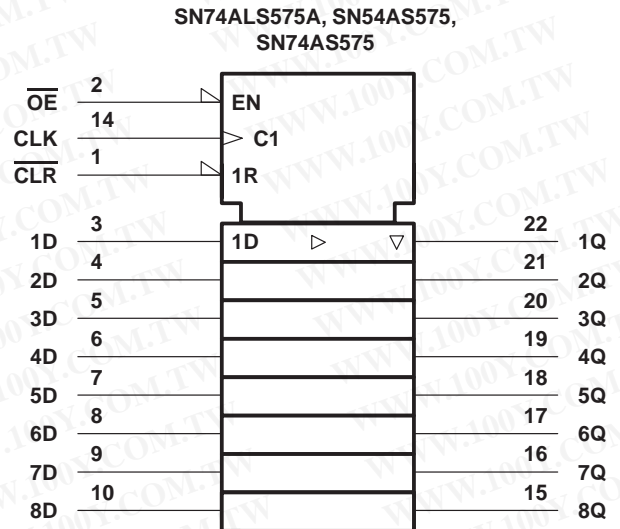
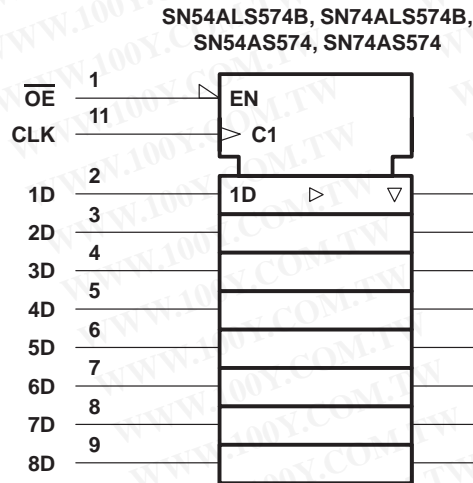

† These symbols are in accordance with ANSI/IEEE Std 91-1984 and IEC Publication 617-12.
Pin numbers shown are for the DW, J, JT, N, and NT packages.

勝特力材料 886-3-5753170
 勝特力电子(上海) 86-21-54151736
 勝特力电子(深圳) 86-755-83298787
[Http://www.100y.com.tw](http://www.100y.com.tw)

SN54ALS574B, SN54AS574, SN54AS575
SN74ALS574B, SN74ALS575A, SN74AS574, SN74AS575
OCTAL D-TYPE EDGE-TRIGGERED FLIP-FLOPS WITH 3-STATE OUTPUTS

SDAS165B – JUNE 1982 – REVISED JULY 1995

logic diagrams (positive logic)

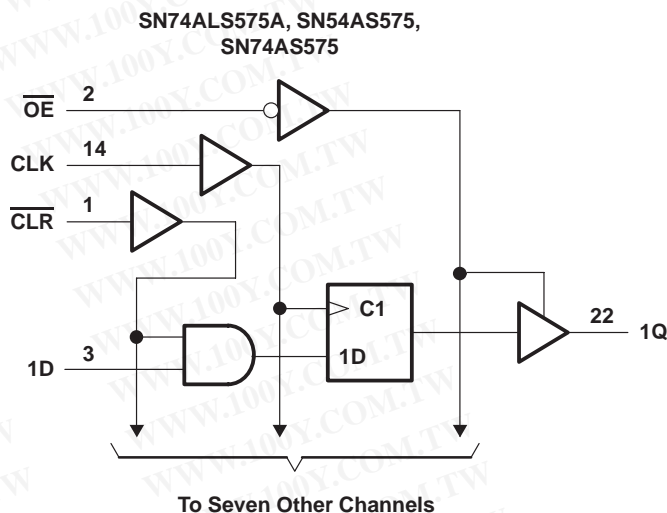
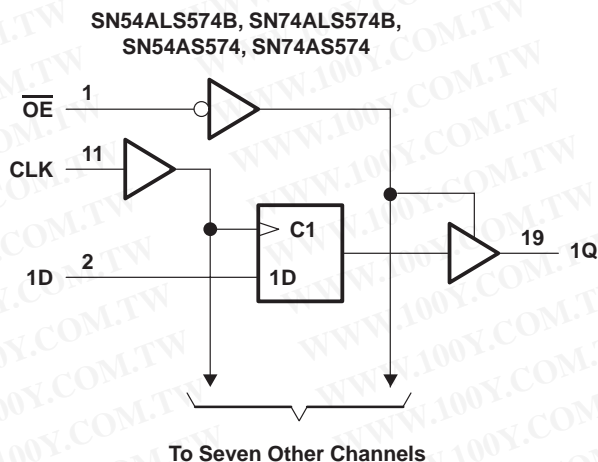

Pin numbers shown are for the DW, J, JT, N, and NT packages.

absolute maximum ratings over operating free-air temperature range (unless otherwise noted)†

| | |
|---|----------------|
| Supply voltage, V_{CC} | 7 V |
| Input voltage, V_I | 7 V |
| Voltage applied to a disabled 3-state output | 5.5 V |
| Operating free-air temperature range, T_A : SN54ALS574B | -55°C to 125°C |
| SN74ALS574B, SN74ALS575A | 0°C to 70°C |
| Storage temperature range | -65°C to 150°C |

† Stresses beyond those listed under "absolute maximum ratings" may cause permanent damage to the device. These are stress ratings only, and functional operation of the device at these or any other conditions beyond those indicated under "recommended operating conditions" is not implied. Exposure to absolute-maximum-rated conditions for extended periods may affect device reliability.

recommended operating conditions

| | | SN54ALS574B | | | SN74ALS574B SN74ALS575A | | | UNIT |
|-------------|--------------------------------|-------------------------------|-----|------|----------------------------|------|------|------|
| | | MIN | NOM | MAX | MIN | NOM | MAX | |
| V_{CC} | Supply voltage | 4.5 | 5 | 5.5 | 4.5 | 5 | 5.5 | V |
| V_{IH} | High-level input voltage | 2 | | | 2 | | | V |
| V_{IL} | Low-level input voltage | | | 0.7 | | | 0.8 | V |
| I_{OH} | High-level output current | | | -1 | | | -2.6 | mA |
| I_{OL} | Low-level output current | | | 12 | | | 24 | mA |
| f_{clock} | Clock frequency | 'ALS574B | | 0 | 28 | 0 | | 35 |
| | | SN74ALS575A | | | | 0 | 30 | MHz |
| t_w | Pulse duration | 'ALS574B, CLK high or low | | 16.5 | | 14 | | ns |
| | | SN74ALS575A, CLK high or low | | | | 16.5 | | |
| t_{su} | Setup time before CLK↑ | Data | | 15 | | 15 | | ns |
| | | SN74ALS575A, \overline{CLR} | | | | 15 | | |
| t_h | Hold time after CLK↑ | Data | | 4 | | 0 | | ns |
| | | SN74ALS575A, \overline{CLR} | | | | 0 | | |
| T_A | Operating free-air temperature | -55 | | 125 | | 0 | 70 | °C |

勝特力材料 886-3-5753170
勝特力电子(上海) 86-21-54151736
勝特力电子(深圳) 86-755-83298787
[Http://www.100y.com.tw](http://www.100y.com.tw)



POST OFFICE BOX 655303 • DALLAS, TEXAS 75265

SN54ALS574B, SN54AS574, SN54AS575
SN74ALS574B, SN74ALS575A, SN74AS574, SN74AS575
OCTAL D-TYPE EDGE-TRIGGERED FLIP-FLOPS WITH 3-STATE OUTPUTS

SDAS165B – JUNE 1982 – REVISED JULY 1995

electrical characteristics over recommended operating free-air temperature range (unless otherwise noted)

| PARAMETER | TEST CONDITIONS | | SN54ALS574B | | | SN74ALS574B SN74ALS575A | | | UNIT |
|-----------------|---|---------------------------|-------------------------|------|------|----------------------------|------|------|---------------|
| | | | MIN | TYP† | MAX | MIN | TYP† | MAX | |
| V_{IK} | $V_{CC} = 4.5\text{ V}$, $I_I = -18\text{ mA}$ | | -1.2 | | | -1.2 | | | V |
| V_{OH} | $V_{CC} = 4.5\text{ V to }5.5\text{ V}$, $I_{OH} = -0.4\text{ mA}$ | | $V_{CC} - 2$ | | | $V_{CC} - 2$ | | | V |
| | $V_{CC} = 4.5\text{ V}$ | $I_{OH} = -1\text{ mA}$ | 2.4 | 3.3 | | | | | |
| | | $I_{OH} = -2.6\text{ mA}$ | | | 2.4 | 3.2 | | | |
| V_{OL} | $V_{CC} = 4.5\text{ V}$ | | $I_{OL} = 12\text{ mA}$ | | 0.25 | 0.4 | 0.25 | 0.4 | V |
| | | | $I_{OL} = 24\text{ mA}$ | | | | 0.35 | 0.5 | |
| I_{OZH} | $V_{CC} = 5.5\text{ V}$, $V_O = 2.7\text{ V}$ | | 20 | | | 20 | | | μA |
| I_{OZL} | $V_{CC} = 5.5\text{ V}$, $V_O = 0.4\text{ V}$ | | -20 | | | -20 | | | μA |
| I_I | $V_{CC} = 5.5\text{ V}$, $V_I = 7\text{ V}$ | | 0.1 | | | 0.1 | | | mA |
| I_{IH} | $V_{CC} = 5.5\text{ V}$, $V_I = 2.7\text{ V}$ | | 20 | | | 20 | | | μA |
| I_{IL} | $V_{CC} = 5.5\text{ V}$, $V_I = 0.4\text{ V}$ | | -0.2 | | | -0.2 | | | mA |
| $I_{O\ddagger}$ | $V_{CC} = 5.5\text{ V}$, $V_O = 2.25\text{ V}$ | | -20 | | -112 | -30 | | -112 | mA |
| I_{CC} | 'ALS574B | $V_{CC} = 5.5\text{ V}$ | Outputs high | | 11 | 18 | 11 | 18 | mA |
| | | | Outputs low | | 17 | 27 | 17 | 27 | |
| | | | Outputs disabled | | 17 | 28 | 17 | 28 | |
| | SN74ALS575A | $V_{CC} = 5.5\text{ V}$ | Outputs high | | 10 | 17 | 10 | 17 | |
| | | | Outputs low | | 15 | 24 | 15 | 24 | |
| | | | Outputs disabled | | 16 | 30 | 16 | 30 | |

† All typical values are at $V_{CC} = 5\text{ V}$, $T_A = 25^\circ\text{C}$.

‡ The output conditions have been chosen to produce a current that closely approximates one half of the true short-circuit output current, I_{OS} .

switching characteristics (see Figure 1)

| PARAMETER | FROM (INPUT) | TO (OUTPUT) | $V_{CC} = 4.5\text{ V to }5.5\text{ V}$, $C_L = 50\text{ pF}$, $R_1 = 500\ \Omega$, $R_2 = 500\ \Omega$, $T_A = \text{MIN to MAX}\S$ | | | | | | UNIT |
|-----------|-----------------|----------------|--|-----|-------------|-----|-------------|-----|------|
| | | | SN54ALS574B | | SN74ALS574B | | SN74ALS575A | | |
| | | | MIN | MAX | MIN | MAX | MIN | MAX | |
| f_{max} | | | 28 | | 35 | | 30 | MHz | |
| t_{PLH} | CLK | Q | 4 | 22 | 3 | 14 | 4 | 14 | ns |
| t_{PHL} | | | 4 | 17 | 4 | 14 | 4 | 14 | |
| t_{PZH} | \overline{OE} | Q | 4 | 21 | 3 | 18 | 4 | 18 | ns |
| t_{PZL} | | | 4 | 26 | 4 | 18 | 4 | 18 | |
| t_{PHZ} | \overline{OE} | Q | 2 | 16 | 1 | 10 | 2 | 10 | ns |
| t_{PLZ} | | | 2 | 25 | 2 | 12 | 3 | 13 | |

§ For conditions shown as MIN or MAX, use the appropriate value specified under recommended operating conditions.

勝特力材料 886-3-5753170
 勝特力电子(上海) 86-21-54151736
 勝特力电子(深圳) 86-755-83298787
[Http://www.100y.com.tw](http://www.100y.com.tw)



SN54ALS574B, SN54AS574, SN54AS575
SN74ALS574B, SN74ALS575A, SN74AS574, SN74AS575
OCTAL D-TYPE EDGE-TRIGGERED FLIP-FLOPS WITH 3-STATE OUTPUTS

SDAS165B – JUNE 1982 – REVISED JULY 1995

absolute maximum ratings over operating free-air temperature range (unless otherwise noted)†

| | |
|--|----------------|
| Supply voltage, V_{CC} | 7 V |
| Input voltage, V_I | 7 V |
| Voltage applied to a disabled 3-state output | 5.5 V |
| Operating free-air temperature range, T_A : SN54AS574, SN54AS575 | –55°C to 125°C |
| SN74AS574, SN74AS575 | 0°C to 70°C |
| Storage temperature range | –65°C to 150°C |

† Stresses beyond those listed under “absolute maximum ratings” may cause permanent damage to the device. These are stress ratings only, and functional operation of the device at these or any other conditions beyond those indicated under “recommended operating conditions” is not implied. Exposure to absolute-maximum-rated conditions for extended periods may affect device reliability.

recommended operating conditions

| | | SN54AS574 SN54AS575 | | | SN74AS574 SN74AS575 | | | UNIT |
|---------------|--------------------------------|-------------------------|-----|-----|------------------------|-----|-----|------|
| | | MIN | NOM | MAX | MIN | NOM | MAX | |
| V_{CC} | Supply voltage | 4.5 | 5 | 5.5 | 4.5 | 5 | 5.5 | V |
| V_{IH} | High-level input voltage | 2 | | | 2 | | | V |
| V_{IL} | Low-level input voltage | | | 0.8 | | | 0.8 | V |
| I_{OH} | High-level output current | | | –12 | | | –15 | mA |
| I_{OL} | Low-level output current | | | 32 | | | 48 | mA |
| f_{clock}^* | Clock frequency | 0 | | 100 | 0 | | 90 | MHz |
| t_w^* | Pulse duration | CLK high | | 5 | 5.5 | | ns | |
| | | CLK low | | 4 | 5.5 | | | |
| t_{su}^* | Setup time before CLK↑ | Data | | 3 | 5.5 | | ns | |
| | | 'AS575, CLR high or low | | 6.5 | 6.5 | | | |
| t_h^* | Hold time after CLK↑ | Data | | 3 | 3 | | ns | |
| | | 'AS575, CLR | | 0 | 0 | | | |
| T_A | Operating free-air temperature | –55 | | 125 | 0 | | 70 | °C |

* On products compliant to MIL-STD-883, Class B, this parameter is based on characterization data but is not production tested.

勝特力材料 886-3-5753170
勝特力电子(上海) 86-21-54151736
勝特力电子(深圳) 86-755-83298787
[Http://www.100y.com.tw](http://www.100y.com.tw)



SN54ALS574B, SN54AS574, SN54AS575
SN74ALS574B, SN74ALS575A, SN74AS574, SN74AS575
OCTAL D-TYPE EDGE-TRIGGERED FLIP-FLOPS WITH 3-STATE OUTPUTS

SDAS165B – JUNE 1982 – REVISED JULY 1995

electrical characteristics over recommended operating free-air temperature range (unless otherwise noted)

| PARAMETER | TEST CONDITIONS | SN54AS574 SN54AS575 | | SN74AS574 SN74AS575 | | UNIT | | |
|-----------------|--|---|------------------|------------------------|------|------|---------------|-----|
| | | MIN | TYP† | MAX | MIN | | TYP† | MAX |
| V_{IK} | $V_{CC} = 4.5\text{ V}$, $I_I = -18\text{ mA}$ | | | -1.2 | | -1.2 | V | |
| V_{OH} | $V_{CC} = 4.5\text{ V to }5.5\text{ V}$, $I_{OH} = -2\text{ mA}$ | $V_{CC} - 2$ | | $V_{CC} - 2$ | | V | | |
| | $V_{CC} = 4.5\text{ V}$ | 2.4 | 3.2 | | | | | |
| V_{OL} | $V_{CC} = 4.5\text{ V}$ | $I_{OH} = -12\text{ mA}$ | | | 2.4 | 3.3 | V | |
| | | $I_{OH} = -15\text{ mA}$ | | | | | | |
| V_{OL} | $V_{CC} = 4.5\text{ V}$ | $I_{OL} = 32\text{ mA}$ | 0.29 | 0.5 | | | V | |
| | | $I_{OL} = 48\text{ mA}$ | | | 0.34 | 0.5 | | |
| I_{OZH} | $V_{CC} = 5.5\text{ V}$, $V_O = 2.7\text{ V}$ | | | 50 | | 50 | μA | |
| I_{OZL} | $V_{CC} = 5.5\text{ V}$, $V_O = 0.4\text{ V}$ | | | -50 | | -50 | μA | |
| I_I | $V_{CC} = 5.5\text{ V}$, $V_I = 7\text{ V}$ | | | 0.1 | | 0.1 | mA | |
| I_{IH} | $V_{CC} = 5.5\text{ V}$, $V_I = 2.7\text{ V}$ | | | 20 | | 20 | μA | |
| I_{IL} | \overline{OE} , CLK, CLR | $V_{CC} = 5.5\text{ V}$, $V_I = 0.4\text{ V}$ | | | -0.5 | | -0.5 | mA |
| | D | | | | -3 | | -2 | |
| $I_{O\ddagger}$ | $V_{CC} = 5.5\text{ V}$, $V_O = 2.25\text{ V}$ | | | -30 | -112 | -30 | -112 | mA |
| I_{CC} | 'AS574 | $V_{CC} = 5.5\text{ V}$ | Outputs high | 73 | 116 | 73 | 116 | mA |
| | | | Outputs low | 85 | 134 | 85 | 134 | |
| | | | Outputs disabled | 84 | 134 | 84 | 134 | |
| | 'AS575 | | Outputs high | 78 | 126 | 78 | 126 | |
| | | | Outputs low | 89 | 142 | 89 | 142 | |
| | | | Outputs disabled | 88 | 142 | 88 | 142 | |

† All typical values are at $V_{CC} = 5\text{ V}$, $T_A = 25^\circ\text{C}$.

‡ The output conditions have been chosen to produce a current that closely approximates one half of the true short-circuit output current, I_{OS} .

switching characteristics (see Figure 1)

| PARAMETER | FROM (INPUT) | TO (OUTPUT) | $V_{CC} = 4.5\text{ V to }5.5\text{ V}$, $C_L = 50\text{ pF}$, $R_1 = 500\ \Omega$, $R_2 = 500\ \Omega$, $T_A = \text{MIN to MAX}\S$ | | | | UNIT |
|-------------|-----------------|----------------|--|-----|------------------------|-----|------|
| | | | SN54AS574 SN54AS575 | | SN74AS574 SN74AS575 | | |
| | | | MIN | MAX | MIN | MAX | |
| f_{max}^* | | | 100 | | 90 | | MHz |
| t_{PLH} | CLK | Any Q | 3 | 11 | 3 | 8 | ns |
| t_{PHL} | | | 4 | 11 | 4 | 9 | |
| t_{PZH} | \overline{OE} | Any Q | 2 | 7 | 2 | 6 | ns |
| t_{PZL} | | | 3 | 11 | 3 | 10 | |
| t_{PHZ} | \overline{OE} | Any Q | 2 | 7 | 2 | 6 | ns |
| t_{PLZ} | | | 2 | 7 | 2 | 6 | |

* On products compliant to MIL-STD-883, Class B, this parameter is based on characterization data but is not production tested.

§ For conditions shown as MIN or MAX, use the appropriate value specified under recommended operating conditions.

**SN54ALS574B, SN54AS574, SN54AS575
SN74ALS574B, SN74ALS575A, SN74AS574, SN74AS575
OCTAL D-TYPE EDGE-TRIGGERED FLIP-FLOPS WITH 3-STATE OUTPUTS**

SDAS165B – JUNE 1982 – REVISED JULY 1995

**PARAMETER MEASUREMENT INFORMATION
SERIES 54ALS/74ALS AND 54AS/74AS DEVICES**

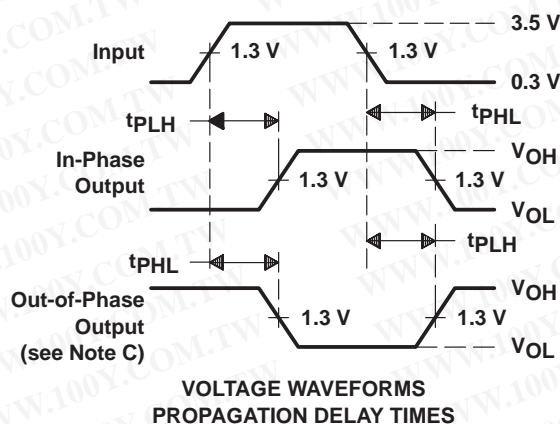
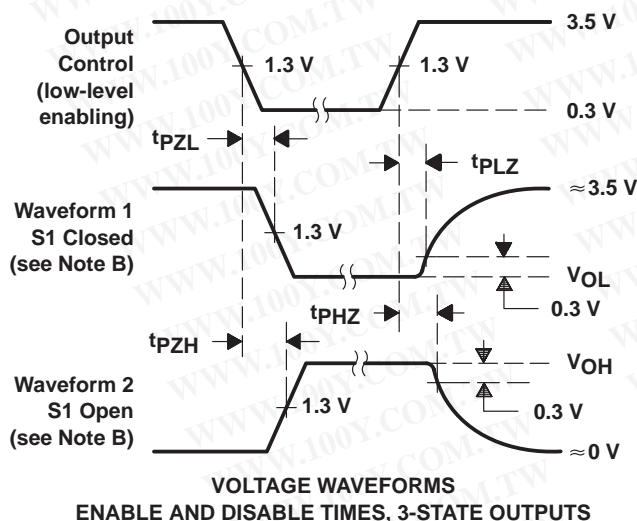
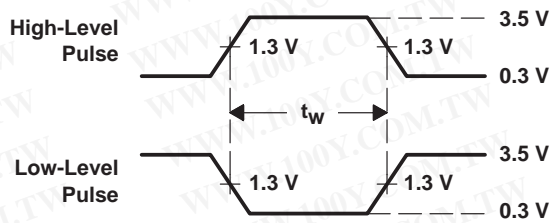
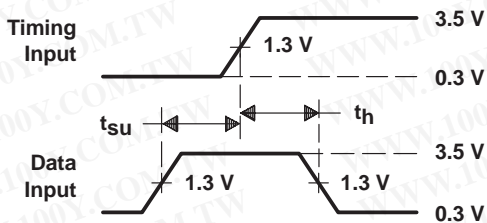
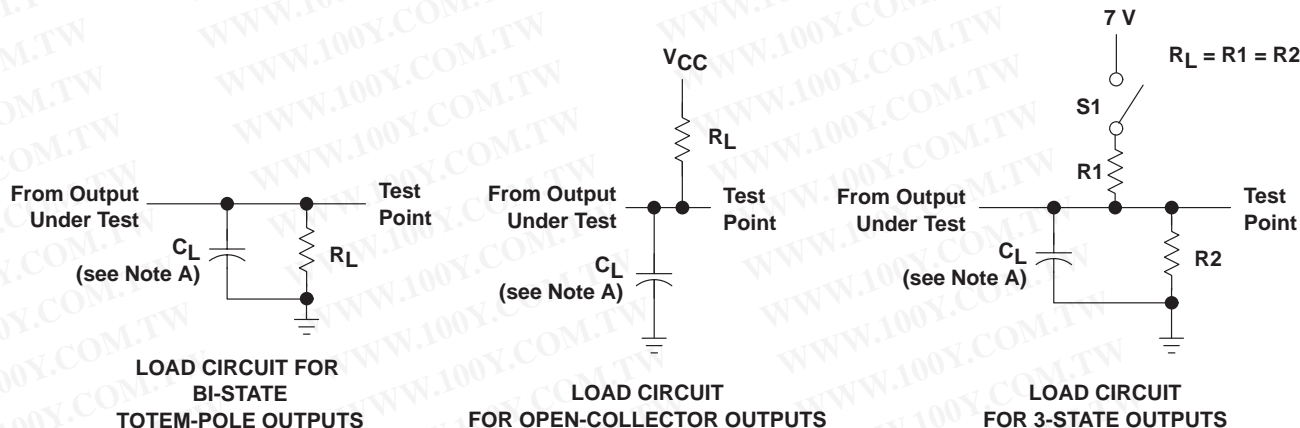

- NOTES: A. C_L includes probe and jig capacitance.
 B. Waveform 1 is for an output with internal conditions such that the output is low except when disabled by the output control. Waveform 2 is for an output with internal conditions such that the output is high except when disabled by the output control.
 C. When measuring propagation delay items of 3-state outputs, switch S_1 is open.
 D. All input pulses have the following characteristics: $PRR \leq 1$ MHz, $t_r = t_f = 2$ ns, duty cycle = 50%.
 E. The outputs are measured one at a time with one transition per measurement.

Figure 1. Load Circuits and Voltage Waveforms



POST OFFICE BOX 655303 • DALLAS, TEXAS 75265

勝特力材料 886-3-5753170
 勝特力电子(上海) 86-21-54151736
 勝特力电子(深圳) 86-755-83298787
[Http://www.100y.com.tw](http://www.100y.com.tw)

IMPORTANT NOTICE

Texas Instruments and its subsidiaries (TI) reserve the right to make changes to their products or to discontinue any product or service without notice, and advise customers to obtain the latest version of relevant information to verify, before placing orders, that information being relied on is current and complete. All products are sold subject to the terms and conditions of sale supplied at the time of order acknowledgement, including those pertaining to warranty, patent infringement, and limitation of liability.

TI warrants performance of its semiconductor products to the specifications applicable at the time of sale in accordance with TI's standard warranty. Testing and other quality control techniques are utilized to the extent TI deems necessary to support this warranty. Specific testing of all parameters of each device is not necessarily performed, except those mandated by government requirements.

CERTAIN APPLICATIONS USING SEMICONDUCTOR PRODUCTS MAY INVOLVE POTENTIAL RISKS OF DEATH, PERSONAL INJURY, OR SEVERE PROPERTY OR ENVIRONMENTAL DAMAGE ("CRITICAL APPLICATIONS"). TI SEMICONDUCTOR PRODUCTS ARE NOT DESIGNED, AUTHORIZED, OR WARRANTED TO BE SUITABLE FOR USE IN LIFE-SUPPORT DEVICES OR SYSTEMS OR OTHER CRITICAL APPLICATIONS. INCLUSION OF TI PRODUCTS IN SUCH APPLICATIONS IS UNDERSTOOD TO BE FULLY AT THE CUSTOMER'S RISK.

In order to minimize risks associated with the customer's applications, adequate design and operating safeguards must be provided by the customer to minimize inherent or procedural hazards.

TI assumes no liability for applications assistance or customer product design. TI does not warrant or represent that any license, either express or implied, is granted under any patent right, copyright, mask work right, or other intellectual property right of TI covering or relating to any combination, machine, or process in which such semiconductor products or services might be or are used. TI's publication of information regarding any third party's products or services does not constitute TI's approval, warranty or endorsement thereof.

Copyright © 1998, Texas Instruments Incorporated

勝特力材料 886-3-5753170
勝特力电子(上海) 86-21-54151736
勝特力电子(深圳) 86-755-83298787
[Http://www.100y.com.tw](http://www.100y.com.tw)