

- State-of-the-Art Advanced BiCMOS Technology (ABT) Design for 3.3-V Operation and Low Static-Power Dissipation
- High-Impedance State During Power Up and Power Down
- Support Mixed-Mode Signal Operation (5-V Input and Output Voltages With 3.3-V V_{CC})
- Support Unregulated Battery Operation Down to 2.7 V
- Typical V_{OLP} (Output Ground Bounce) <0.8 V at $V_{CC} = 3.3$ V, $T_A = 25^\circ\text{C}$
- I_{off} and Power-Up 3-State Support Hot Insertion
- Latch-Up Performance Exceeds 100 mA Per JESD 78, Class II
- ESD Protection Exceeds JESD 22
 - 2000-V Human-Body Model (A114-A)
 - 200-V Machine Model (A115-A)
 - 1000-V Charged-Device Model (C101)
- Package Options Include Plastic Small-Outline (DW), Shrink Small-Outline (DB), and Thin Shrink Small-Outline (PW) Packages, Ceramic Chip Carriers (FK), Ceramic Flat (W) Packages, and Ceramic (J) DIPs

SN54LVT244B . . . J OR W PACKAGE
 SN74LVT244B . . . DB, DW, OR PW PACKAGE
 (TOP VIEW)

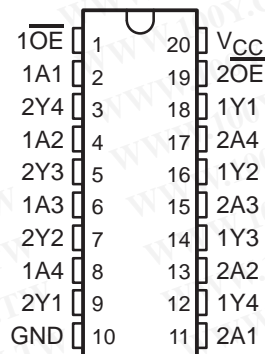

SN54LVT244B . . . FK PACKAGE
 (TOP VIEW)

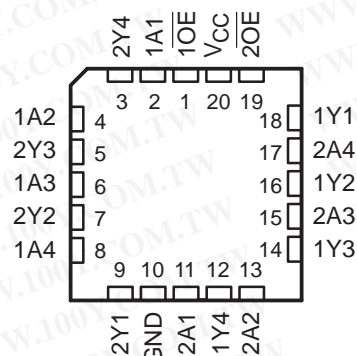

description

These octal buffers and line drivers are designed specifically for low-voltage (3.3-V) V_{CC} operation, but with the capability to provide a TTL interface to a 5-V system environment.

The 'LVT244B is organized as two 4-bit line drivers with separate output-enable (\overline{OE}) inputs. When \overline{OE} is low, the device passes data from the A inputs to the Y outputs. When \overline{OE} is high, the outputs are in the high-impedance state.

When V_{CC} is between 0 and 1.5 V, the device is in the high-impedance state during power up or power down. However, to ensure the high-impedance state above 1.5 V, \overline{OE} should be tied to V_{CC} through a pullup resistor; the minimum value of the resistor is determined by the current-sinking capability of the driver.

These devices are fully specified for hot-insertion applications using I_{off} and power-up 3-state. The I_{off} circuitry disables the outputs, preventing damaging current backflow through the devices when they are powered down. The power-up 3-state circuitry places the outputs in the high-impedance state during power up and power down, which prevents driver conflict.

The SN54LVT244B is characterized for operation over the full military temperature range of -55°C to 125°C . The SN74LVT244B is characterized for operation from -40°C to 85°C .



Please be aware that an important notice concerning availability, standard warranty, and use in critical applications of Texas Instruments semiconductor products and disclaimers thereto appears at the end of this data sheet.

SN54LVT244B, SN74LVT244B

3.3-V ABT OCTAL BUFFERS/DRIVERS

WITH 3-STATE OUTPUTS

SCAS354F – FEBRUARY 1994 – REVISED APRIL 2000

FUNCTION TABLE
(each 4-bit buffer)

INPUTS		OUTPUT Y
\overline{OE}	A	
L	H	H
L	L	L
H	X	Z

勝特力材料 886-3-5753170
 勝特力电子(上海) 86-21-54151736
 勝特力电子(深圳) 86-755-83298787
[Http://www.100y.com.tw](http://www.100y.com.tw)

logic symbol†

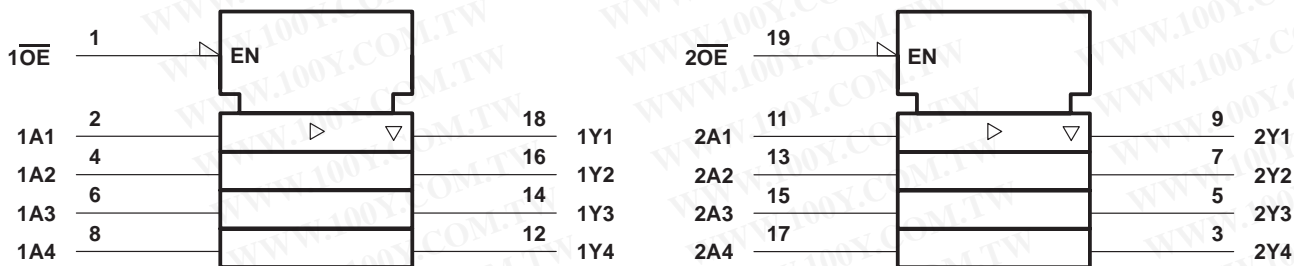

† This symbol is in accordance with ANSI/IEEE Std 91-1984 and IEC Publication 617-12.

logic diagram (positive logic)

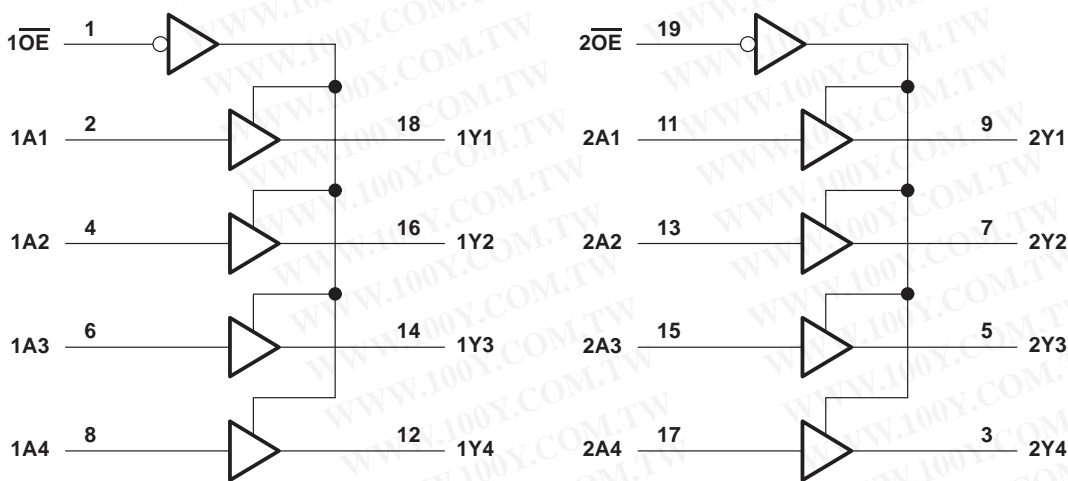

SN54LVT244B, SN74LVT244B
3.3-V ABT OCTAL BUFFERS/DRIVERS
WITH 3-STATE OUTPUTS

SCAS354F – FEBRUARY 1994 – REVISED APRIL 2000

absolute maximum ratings over operating free-air temperature range (unless otherwise noted)†

Supply voltage range, V_{CC}	-0.5 V to 4.6 V
Input voltage range, V_I (see Note 1)	-0.5 V to 7 V
Voltage range applied to any output in the high-impedance or power-off state, V_O (see Note 1)	-0.5 V to 7 V
Voltage range applied to any output in the high state, V_O (see Note 1)	-0.5 V to $V_{CC} + 0.5$ V
Current into any output in the low state, I_O : SN54LVT244B	96 mA
SN74LVT244B	128 mA
Current into any output in the high state, I_O (see Note 2): SN54LVT244B	48 mA
SN74LVT244B	64 mA
Input clamp current, I_{IK} ($V_I < 0$)	-50 mA
Output clamp current, I_{OK} ($V_O < 0$)	-50 mA
Package thermal impedance, θ_{JA} (see Note 3): DB package	70°C/W
DW package	58°C/W
PW package	83°C/W
Storage temperature range, T_{stg}	-65°C to 150°C

† Stresses beyond those listed under “absolute maximum ratings” may cause permanent damage to the device. These are stress ratings only, and functional operation of the device at these or any other conditions beyond those indicated under “recommended operating conditions” is not implied. Exposure to absolute-maximum-rated conditions for extended periods may affect device reliability.

- NOTES: 1. The input and output negative-voltage ratings may be exceeded if the input and output clamp-current ratings are observed.
2. This current flows only when the output is in the high state and $V_O > V_{CC}$.
3. The package thermal impedance is calculated in accordance with JESD 51.

recommended operating conditions (see Note 4)

	SN54LVT244B		SN74LVT244B		UNIT
	MIN	MAX	MIN	MAX	
V_{CC} Supply voltage	2.7	3.6	2.7	3.6	V
V_{IH} High-level input voltage	2		2		V
V_{IL} Low-level input voltage		0.8		0.8	V
V_I Input voltage		5.5		5.5	V
I_{OH} High-level output current		-24		-32	mA
I_{OL} Low-level output current		48		64	mA
$\Delta t/\Delta v$ Input transition rise or fall rate	Outputs enabled		10	10	ns/V
$\Delta t/\Delta V_{CC}$ Power-up ramp rate	200		200		μ s/V
T_A Operating free-air temperature	-55	125	-40	85	°C

NOTE 4: All unused inputs of the device must at V_{CC} or GND to ensure proper device operation. Refer to the TI application report, *Implications of Slow or Floating CMOS Inputs*, literature number SCBA004.

勝特力材料 886-3-5753170
胜特力电子(上海) 86-21-54151736
胜特力电子(深圳) 86-755-83298787
[Http://www.100y.com.tw](http://www.100y.com.tw)

SN54LVT244B, SN74LVT244B
3.3-V ABT OCTAL BUFFERS/DRIVERS
WITH 3-STATE OUTPUTS

SCAS354F – FEBRUARY 1994 – REVISED APRIL 2000

勝特力材料 886-3-5753170
 勝特力电子(上海) 86-21-54151736
 勝特力电子(深圳) 86-755-83298787
 Http://www.100y.com.tw

electrical characteristics over recommended operating free-air temperature range (unless otherwise noted)

PARAMETER	TEST CONDITIONS		SN54LVT244B			SN74LVT244B			UNIT
			MIN	TYP†	MAX	MIN	TYP†	MAX	
V _{IK}	V _{CC} = 2.7 V,	I _I = -18 mA			-1.2			-1.2	V
V _{OH}	V _{CC} = 2.7 V to 3.6 V, I _{OH} = -100 μA		V _{CC} -0.2			V _{CC} -0.2			V
	V _{CC} = 2.7 V, I _{OH} = -8 mA		2.4			2.4			
	V _{CC} = 3 V		2			2			
V _{OL}	V _{CC} = 2.7 V		I _{OL} = 100 μA			0.2			V
			I _{OL} = 24 mA			0.5			
			I _{OL} = 16 mA			0.4			
			I _{OL} = 32 mA			0.5			
			I _{OL} = 48 mA			0.55			
			I _{OL} = 64 mA			0.55			
I _I	V _{CC} = 0 or 3.6 V, V _I = 5.5 V		10			10			μA
	Control inputs V _{CC} = 3.6 V, V _I = V _{CC} or GND		±1			±1			
	Data inputs V _{CC} = 3.6 V		1			1			
			-5			-5			
I _{off}	V _{CC} = 0, V _I or V _O = 0 to 4.5 V					±100			μA
I _{OZH}	V _{CC} = 3.6 V, V _O = 3 V		5			5			μA
I _{OZL}	V _{CC} = 3.6 V, V _O = 0.5 V		-5			-5			μA
I _{OZPU}	V _{CC} = 0 to 1.5 V, V _O = 0.5 V to 3 V, OE = don't care		±100*			±100			μA
I _{OZPD}	V _{CC} = 1.5 V to 0, V _O = 0.5 V to 3 V, OE = don't care		±100*			±100			μA
I _{CC}	V _{CC} = 3.6 V, I _O = 0, V _I = V _{CC} or GND		Outputs high			0.19			mA
			Outputs low			5			
			Outputs disabled			0.19			
ΔI _{CC} ‡	V _{CC} = 3 V to 3.6 V, One input at V _{CC} - 0.6 V, Other inputs at V _{CC} or GND		0.3			0.2			mA
C _i	V _I = 3 V or 0		4			4			pF
C _o	V _O = 3 V or 0		7			7			pF

* On products compliant to MIL-PRF-38535, this parameter is not production tested.

† All typical values are at V_{CC} = 3.3 V, T_A = 25°C.

‡ This is the increase in supply current for each input that is at the specified TTL voltage level rather than V_{CC} or GND.

PRODUCT PREVIEW information concerns products in the formative or design phase of development. Characteristic data and other specifications are design goals. Texas Instruments reserves the right to change or discontinue these products without notice.



SN54LVT244B, SN74LVT244B
3.3-V ABT OCTAL BUFFERS/DRIVERS
WITH 3-STATE OUTPUTS

SCAS354F – FEBRUARY 1994 – REVISED APRIL 2000

switching characteristics over recommended operating free-air temperature range, $C_L = 50$ pF (unless otherwise noted) (see Figure 1)

PARAMETER	FROM (INPUT)	TO (OUTPUT)	SN54LVT244B				SN74LVT244B				UNIT	
			$V_{CC} = 3.3\text{ V} \pm 0.3\text{ V}$		$V_{CC} = 2.7\text{ V}$		$V_{CC} = 3.3\text{ V} \pm 0.3\text{ V}$			$V_{CC} = 2.7\text{ V}$		
			MIN	MAX	MIN	MAX	MIN	TYP†	MAX	MIN		MAX
t_{PLH}	A	Y	1	3.6		3.9	1.1	2.3	3.5		3.8	ns
t_{PHL}			1.2	3.4		3.6	1.3	2.1	3.3		3.6	
t_{PZH}	\overline{OE}	Y	1	4.6		5.5	1.1	2.5	4.5		5.3	ns
t_{PZL}			1.3	4.5		5.1	1.4	2.7	4.4		4.9	
t_{PHZ}	\overline{OE}	Y	1.8	4.5		4.7	1.9	2.8	4.4		4.5	ns
t_{PLZ}			1.7	4.5		4.6	1.8	2.9	4.4		4.4	

† All typical values are at $V_{CC} = 3.3\text{ V}$, $T_A = 25^\circ\text{C}$.

勝特力材料 886-3-5753170
勝特力电子(上海) 86-21-54151736
勝特力电子(深圳) 86-755-83298787
[Http://www.100y.com.tw](http://www.100y.com.tw)

SN54LVT244B, SN74LVT244B
3.3-V ABT OCTAL BUFFERS/DRIVERS
WITH 3-STATE OUTPUTS

SCAS354F – FEBRUARY 1994 – REVISED APRIL 2000

勝特力材料 886-3-5753170
 勝特力电子(上海) 86-21-54151736
 勝特力电子(深圳) 86-755-83298787
[Http://www.100y.com.tw](http://www.100y.com.tw)

PARAMETER MEASUREMENT INFORMATION

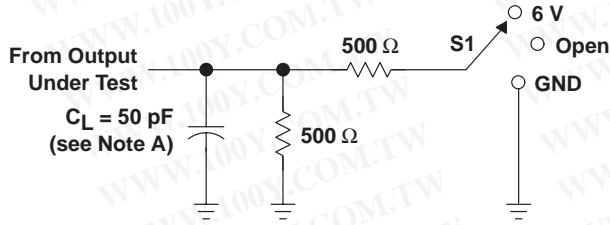

TEST	S1
t _{PLH} /t _{PHL}	Open
t _{PLZ} /t _{PZL}	6 V
t _{PHZ} /t _{PZH}	GND

LOAD CIRCUIT

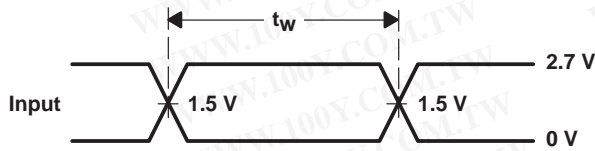

VOLTAGE WAVEFORMS PULSE DURATION

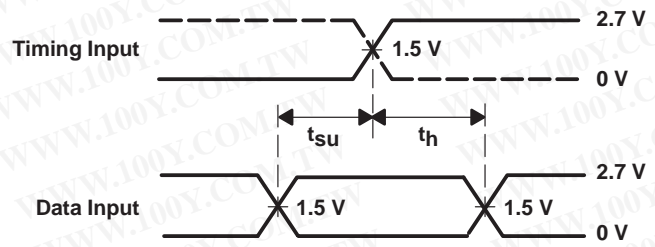

VOLTAGE WAVEFORMS SETUP AND HOLD TIMES

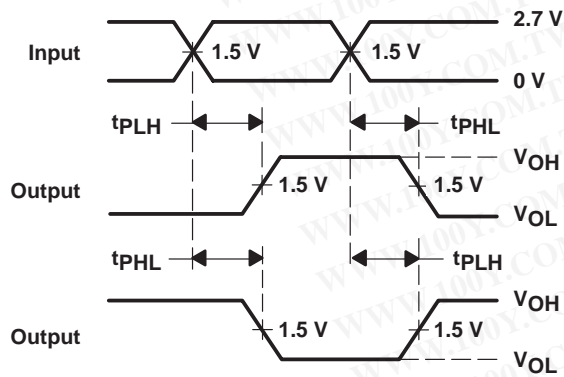

VOLTAGE WAVEFORMS PROPAGATION DELAY TIMES INVERTING AND NONINVERTING OUTPUTS

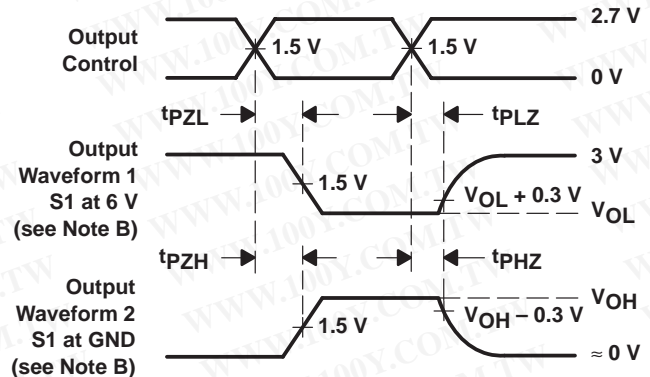

VOLTAGE WAVEFORMS ENABLE AND DISABLE TIMES LOW- AND HIGH-LEVEL ENABLING

- NOTES: A. C_L includes probe and jig capacitance.
 B. Waveform 1 is for an output with internal conditions such that the output is low except when disabled by the output control. Waveform 2 is for an output with internal conditions such that the output is high except when disabled by the output control.
 C. All input pulses are supplied by generators having the following characteristics: $PRR \leq 10$ MHz, $Z_O = 50 \Omega$, $t_r \leq 2.5$ ns, $t_f \leq 2.5$ ns.
 D. The outputs are measured one at a time with one transition per measurement.

Figure 1. Load Circuit and Voltage Waveforms