



SEMIPACK[®] 1

Rectifier Diode Modules

SKKD 46

Features

- Heat transfer through aluminium oxide ceramic isolated metal baseplate
- Hard soldered joints for high reliability
- UL recognized, file no. E 63 532

Typical Applications

- Non-controllable rectifiers for AC/AC converters
- Line rectifiers for transistorized AC motor controllers
- Field supply for DC motors

V_{RSM} V	V_{RRM} V	$I_{FRMS} = 90$ A (maximum value for continuous operation) $I_{FAV} = 45$ A (sin. 180; $T_c = 86$ °C)	
500	400	SKKD 46/04	
700	600	SKKD 46/06	
900	800	SKKD 46/08	
1300	1200	SKKD 46/12	
1500	1400	SKKD 46/14	
1700	1600	SKKD 46/16	
1900	1800	SKKD 46/18	

Symbol	Conditions	Values	Units
I_{FAV}	sin. 180; $T_c = 85$ (100) °C	47 (33)	A
I_D	P3/120; $T_a = 45$ °C; B2 / B6	50 / 60	A
	P3/180F; $T_a = 35$ °C; B2 / B6	95 / 120	A
I_{FSM}	$T_{vj} = 25$ °C; 10 ms	700	A
	$T_{vj} = 125$ °C; 10 ms	600	A
i^2t	$T_{vj} = 25$ °C; 8,3 ... 10 ms	2450	A ² s
	$T_{vj} = 125$ °C; 8,3 ... 10 ms	1800	A ² s
V_F	$T_{vj} = 25$ °C; $I_F = 250$ A	max. 1,95	V
$V_{(TO)}$	$T_{vj} = 125$ °C	0,85	V
r_T	$T_{vj} = 125$ °C	5	mΩ
I_{RD}	$T_{vj} = 125$ °C; $V_{RD} = V_{RRM}$	max. 3	mA
$R_{th(j-c)}$	per diode / per module	0,6 / 0,3	K/W
$R_{th(c-s)}$	per diode / per module	0,2 / 0,1	K/W
T_{vj}		- 40 ... + 125	°C
T_{stg}		- 40 ... + 125	°C
V_{isol}	a. c. 50 Hz; r.m.s.; 1 s / 1 min.	3600 / 3000	V~
M_s	to heatsink	5 ± 15 %	Nm
M_t	to terminals	3 ± 15 %	Nm
a		5 * 9,81	m/s ²
m	approx.	95	g
Case		A 10	

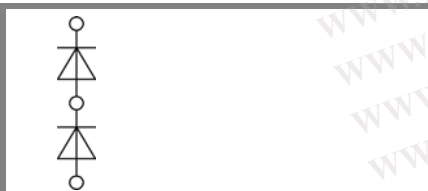

SKKD

勝特力材料 886-3-5753170
 勝特力电子(上海) 86-21-54151736
 勝特力电子(深圳) 86-755-83298787
[Http://www.100y.com.tw](http://www.100y.com.tw)

SKKD 46

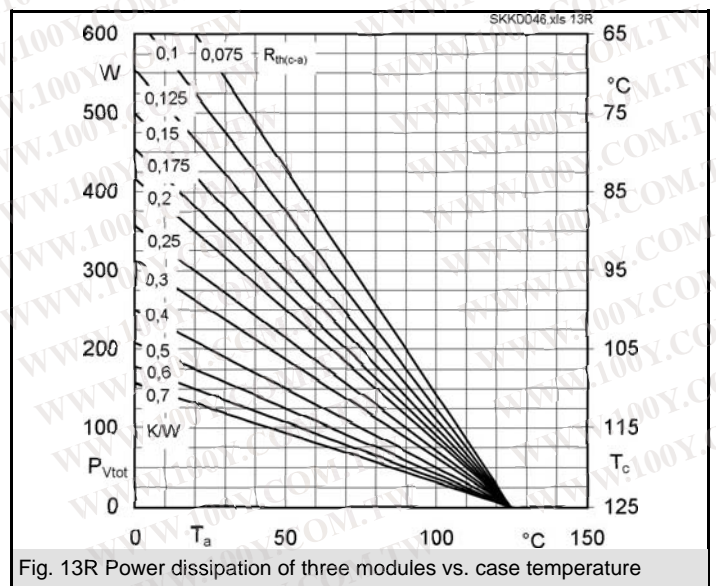
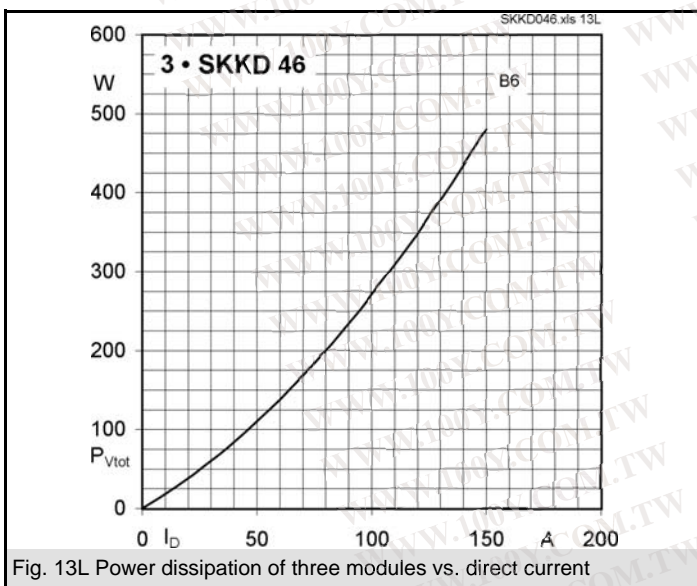
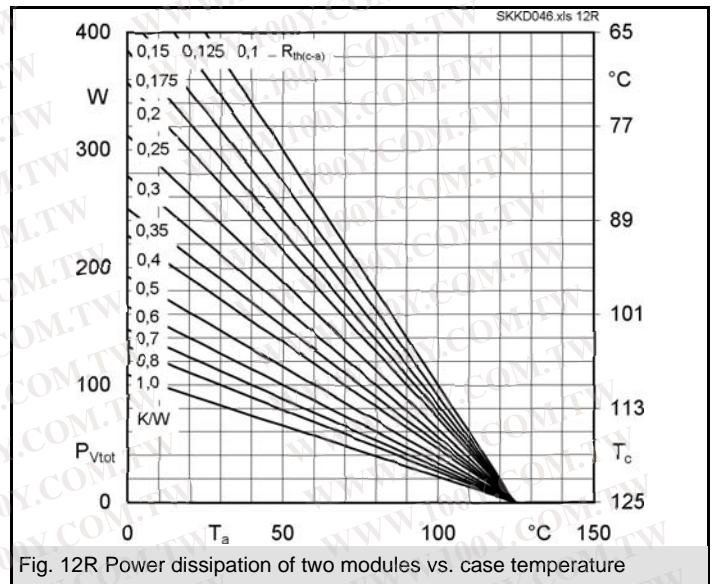
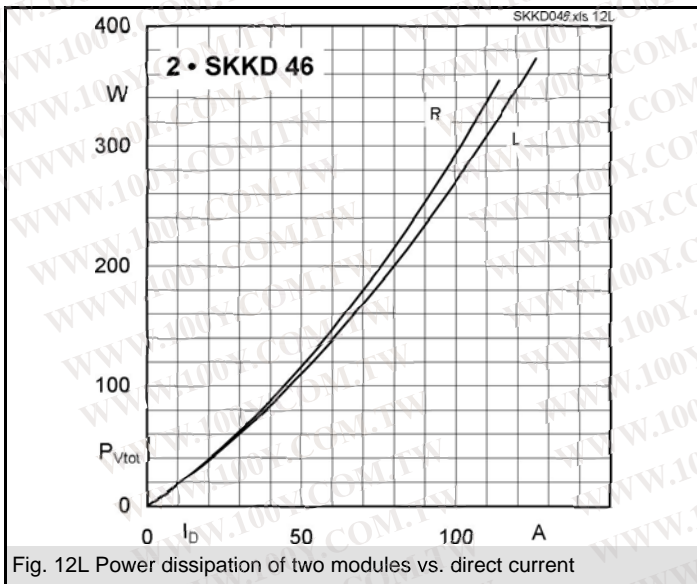
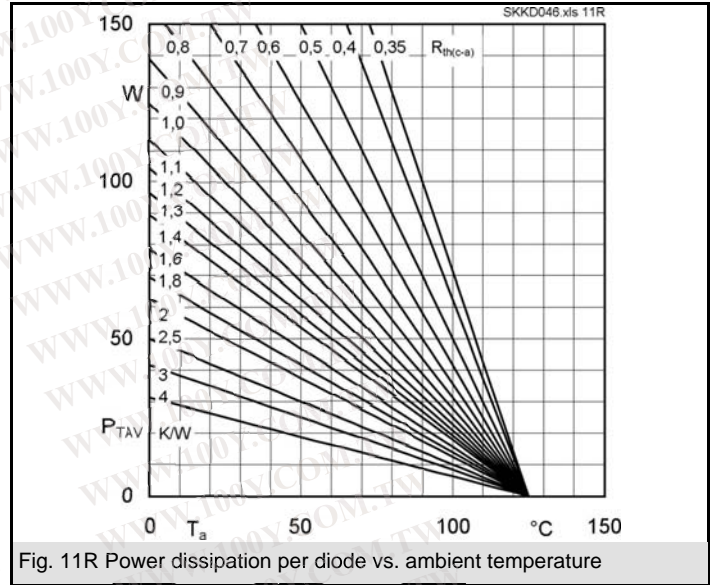
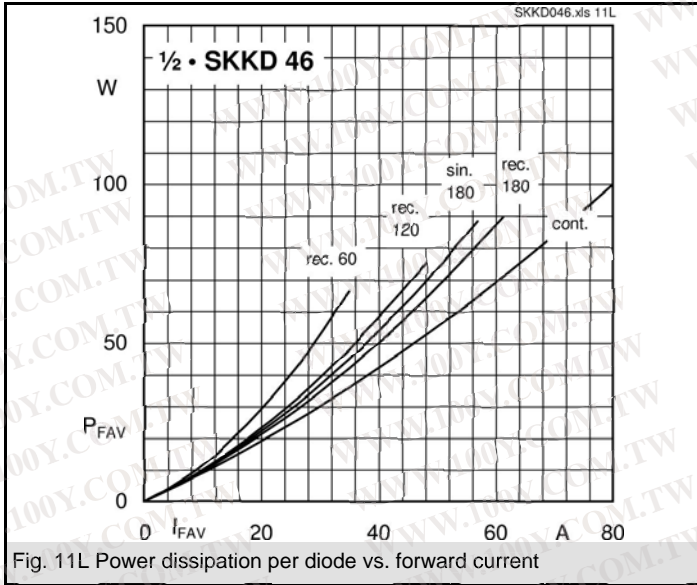

勝特力材料 886-3-5753170
 勝特力电子(上海) 86-21-54151736
 勝特力电子(深圳) 86-755-83298787
[Http://www.100y.com.tw](http://www.100y.com.tw)

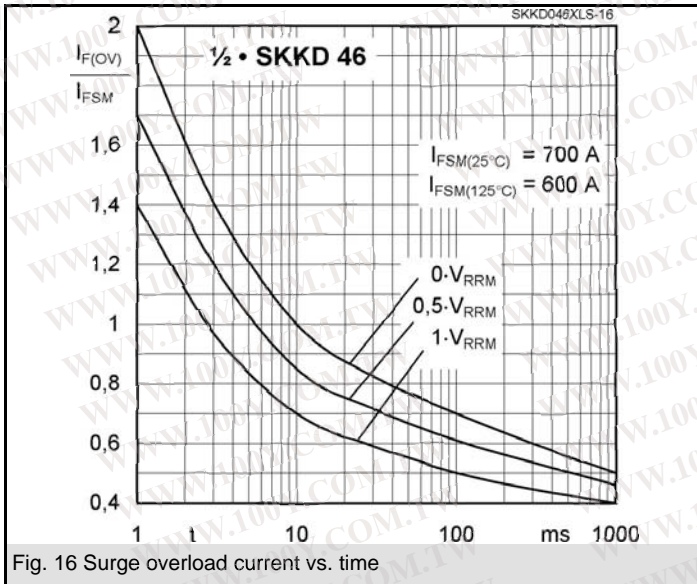
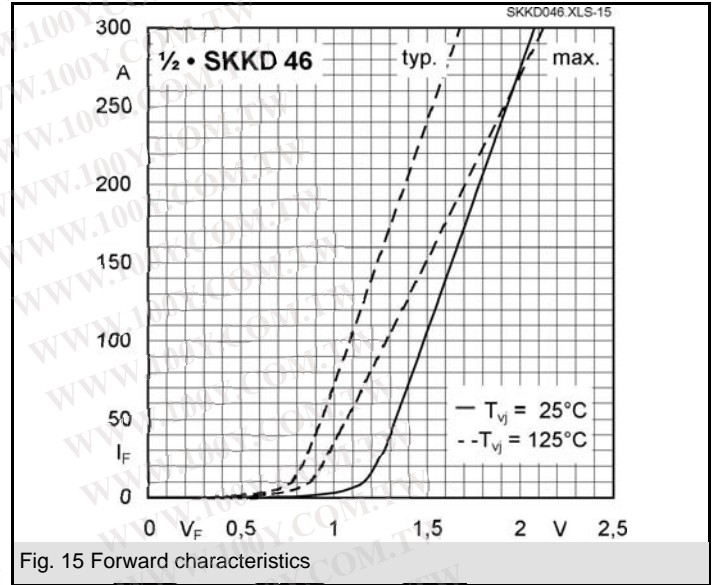
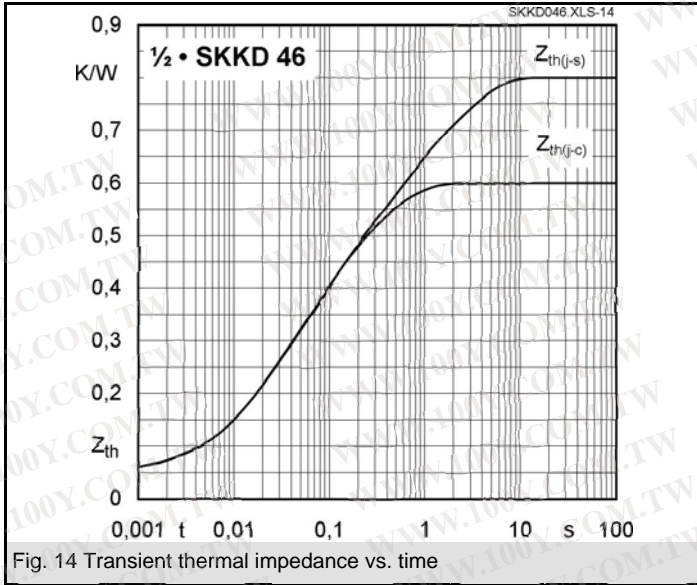

勝特力材料 86-3-5753170
 勝特力电子(上海) 86-21-54151736
 勝特力电子(深圳) 86-755-83298787
[Http://www.100y.com.tw](http://www.100y.com.tw)

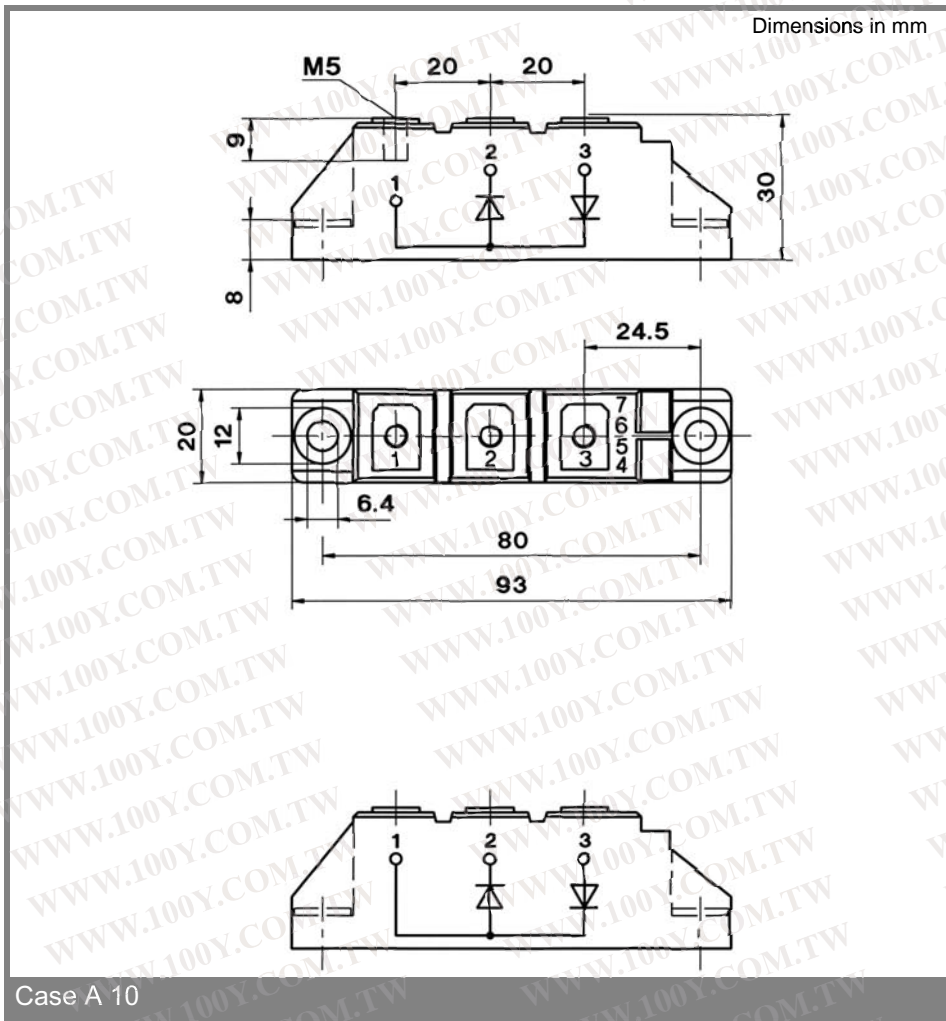

This technical information specifies semiconductor devices but promises no characteristics. No warranty or guarantee expressed or implied is made regarding delivery, performance or suitability.

勝特力材料 886-3-5753170
 勝特力电子(上海) 86-21-54151736
 勝特力电子(深圳) 86-755-83298787
[Http://www.100y.com.tw](http://www.100y.com.tw)