

SIEMENS

勝特力材料 886-3-5753170
勝特力电子(上海) 86-21-54151736
勝特力电子(深圳) 86-755-83298787
[Http://www.100y.com.tw](http://www.100y.com.tw)

Microcomputer Components

8-Bit CMOS Microcontroller

C515

C515 Data Sheet		
Revision History:		Current Version: 1997-08-01
Previous Version:		none (Original Version)
Page (in previous Version)	Page (in current Version)	Subjects (major changes since last revision)

勝特力材料 886-3-5753170
 勝特力电子(上海) 86-21-54151736
 勝特力电子(深圳) 86-755-83298787
[Http://www.100y.com.tw](http://www.100y.com.tw)

Edition 1997-08-01

**Published by Siemens AG,
Bereich Halbleiter, Marketing-
Kommunikation, Balanstraße 73,
81541 München**

© Siemens AG 1997.
All Rights Reserved.

Attention please!

As far as patents or other rights of third parties are concerned, liability is only assumed for components, not for applications, processes and circuits implemented within components or assemblies.

The information describes the type of component and shall not be considered as assured characteristics.

Terms of delivery and rights to change design reserved.

For questions on technology, delivery and prices please contact the Semiconductor Group Offices in Germany or the Siemens Companies and Representatives worldwide (see address list).

Due to technical requirements components may contain dangerous substances. For information on the types in question please contact your nearest Siemens Office, Semiconductor Group.

Siemens AG is an approved CECC manufacturer.

Packing

Please use the recycling operators known to you. We can also help you – get in touch with your nearest sales office. By agreement we will take packing material back, if it is sorted. You must bear the costs of transport.

For packing material that is returned to us unsorted or which we are not obliged to accept, we shall have to invoice you for any costs incurred.

Components used in life-support devices or systems must be expressly authorized for such purpose!

Critical components¹ of the Semiconductor Group of Siemens AG, may only be used in life-support devices or systems² with the express written approval of the Semiconductor Group of Siemens AG.

- 1 A critical component is a component used in a life-support device or system whose failure can reasonably be expected to cause the failure of that life-support device or system, or to affect its safety or effectiveness of that device or system.
- 2 Life support devices or systems are intended (a) to be implanted in the human body, or (b) to support and/or maintain and sustain human life. If they fail, it is reasonable to assume that the health of the user may be endangered.

8-Bit CMOS Microcontroller

C515

勝特力材料 886-3-5753170
 勝特力电子(上海) 86-21-54151736
 勝特力电子(深圳) 86-755-83298787
[Http://www.100y.com.tw](http://www.100y.com.tw)

Advance Information

Data Sheet

- Full upward compatibility with SAB 80C515
- Up to 24 MHz external operating frequency
 - 500ns instruction cycle at 24 MHz operation
- 8K byte on-chip ROM (with optional ROM protection)
 - alternatively up to 64K byte external program memory
- Up to 64K byte external data memory
- 256 byte on-chip RAM
- Six 8-bit parallel I/O ports
- One input port for analog/digital input
- Full duplex serial interface (USART)
 - 4 operating modes, fixed or variable baud rates
- Three 16-bit timer/counters
 - Timer 0 / 1 (C501 compatible)
 - Timer 2 for 16-bit reload, compare, or capture functions

(more features on next page)

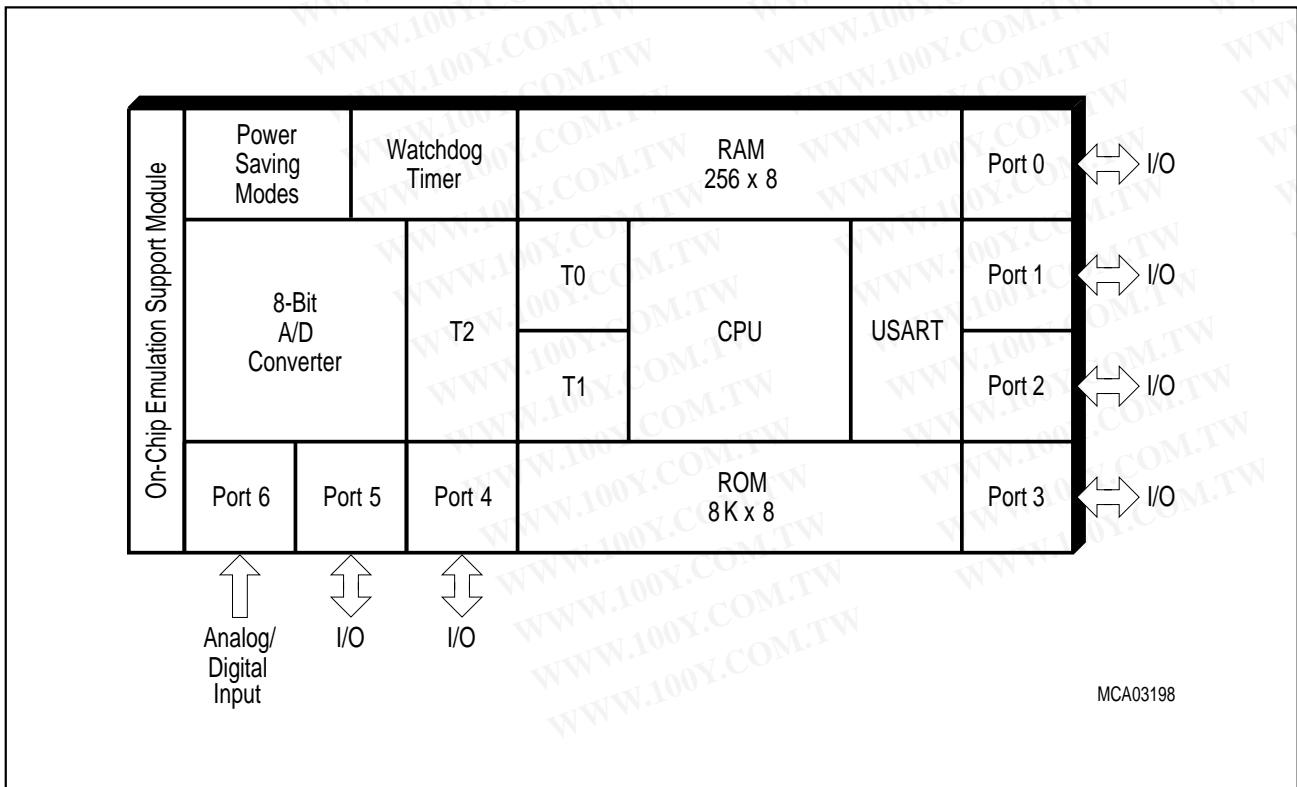

Figure 1
C515 Functional Units

Features (cont'd):

- 8-bit A/D converter
 - 8 multiplexed analog inputs
 - Programmable reference voltages
- 16-bit watchdog timer
- Power saving modes
 - Idle mode
 - Slow down mode (can be combined with idle mode)
 - Software power-down mode
- 12 interrupt sources (7 external, 5 internal) selectable at four priority levels
- On-chip emulation support logic (Enhanced Hooks Technology™)
- ALE switch-off capability
- P-MQFP-80-1 package
- Temperature Ranges :

SAB-C515	$T_A = 0 \text{ to } 70 \text{ }^\circ\text{C}$
SAF-C515	$T_A = -40 \text{ to } 85 \text{ }^\circ\text{C}$
SAH-C515	$T_A = -40 \text{ to } 110 \text{ }^\circ\text{C}$ (max. operating frequency: 16 MHz)

勝特力材料 886-3-5753170
 勝特力电子(上海) 86-21-54151736
 勝特力电子(深圳) 86-755-83298787
[Http://www.100y.com.tw](http://www.100y.com.tw)

The C515 is an upward compatible version of the SAB 80C515A 8-bit microcontroller which additionally provides ALE switch-off capability, on-chip emulation support, ROM protection, and slow down mode capability. With a maximum external clock rate of 24 MHz it achieves a 500 ns instruction cycle time (1 μs at 12 MHz). The C515 is mounted in a P-MQFP-80 package.

Ordering Information

Type	Ordering Code	Package	Description (8-Bit CMOS microcontroller)
SAB-C515-1RM	Q67127-DXXXX	P-MQFP-80-1	with mask programmable ROM (16 MHz)
SAB-C515-1R24M	Q67127-DXXXX	P-MQFP-80-1	with mask programmable ROM (24 MHz)
SAF-C515-1RM	Q67127-DXXXX	P-MQFP-80-1	with mask programmable ROM (16 MHz) ext. temp. – 40 °C to 85 °C
SAF-C515-1R24M	Q67127-DXXXX	P-MQFP-80-1	with mask programmable ROM (24 MHz) ext. temp. – 40 °C to 85 °C
SAB-C515-LM	Q67127-C1030	P-MQFP-80-1	for external memory (16 MHz)
SAB-C515-L24M	Q67127-C1032	P-MQFP-80-1	for external memory (24 MHz)
SAF-C515-LM	Q67127-C1031	P-MQFP-80-1	for external memory (16 MHz) ext. temp. – 40 °C to 85 °C
SAF-C515-L24M	Q67127-C1081	P-MQFP-80-1	for external memory (24 MHz) ext. temp. – 40 °C to 85 °C

Note: Versions for extended temperature ranges – 40 °C to 110 °C (SAH-C515C-LM and SAH-C515-1RM) are available on request. The ordering number of ROM types (DXXXX extensions) is defined after program release (verification) of the customer.

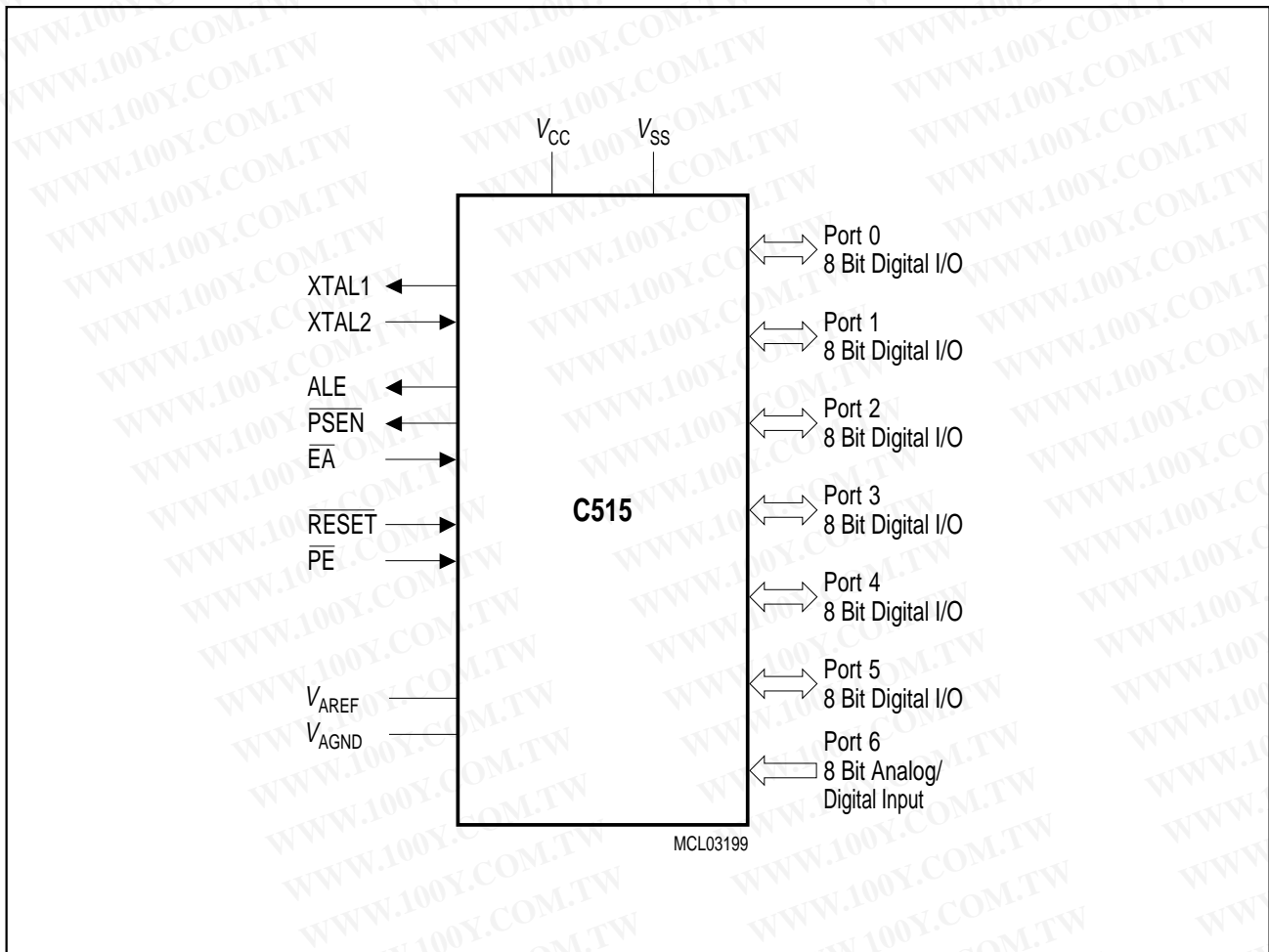

Figure 2
Logic Symbol

Additional Literature

For further information about the C515 the following literature is available:

Title	Ordering Number
C515 8-Bit CMOS Microcontroller User's Manual	B158-H7049-X-X-7600
C500 Microcontroller Family Architecture and Instruction Set User's Manual	B158-H6987-X-X-7600
C500 Microcontroller Family - Pocket Guide	B158-H6986-X-X-7600

勝特力材料 886-3-5753170
勝特力电子(上海) 86-21-54151736
勝特力电子(深圳) 86-755-83298787
[Http://www.100y.com.tw](http://www.100y.com.tw)

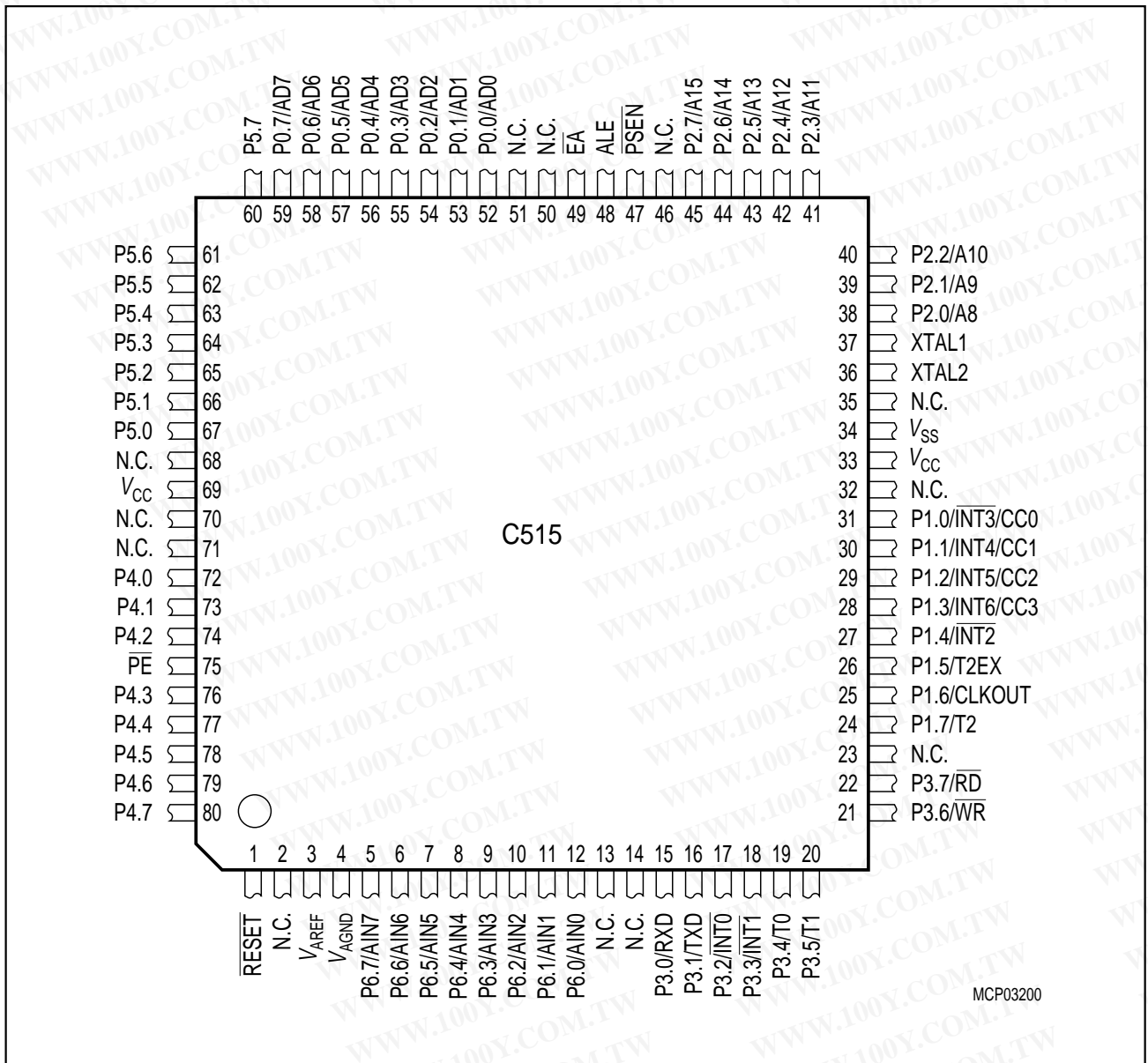

Figure 3
C515 Pin Configuration (P-MQFP-80 Package, Top View)

勝特力材料 886-3-5753170
 勝特力电子(上海) 86-21-54151736
 勝特力电子(深圳) 86-755-83298787
[Http://www.100y.com.tw](http://www.100y.com.tw)

Table 1
Pin Definitions and Functions

Symbol	Pin Number (P-MQFP-80)	I/O*	Function
RESET	1	I	RESET A low level on this pin for the duration of two machine cycles while the oscillator is running resets the C515. A small internal pullup resistor permits power-on reset using only a capacitor connected to V_{SS} .
VAREF	3	–	Reference voltage for the A/D converter
VAGND	4	–	Reference ground for the A/D converter
P6.0-P6.7	12-5	I	Port 6 is an 8-bit unidirectional input port to the A/D converter. Port pins can be used for digital input, if voltage levels simultaneously meet the specifications for high/low input voltages and for the eight multiplexed analog inputs.

*) I = Input
O = Output

勝特力材料 886-3-5753170
 勝特力电子(上海) 86-21-54151736
 勝特力电子(深圳) 86-755-83298787
[Http://www.100y.com.tw](http://www.100y.com.tw)

勝特力材料 886-3-5753170
 勝特力电子(上海) 86-21-54151736
 勝特力电子(深圳) 86-755-83298787
[Http://www.100y.com.tw](http://www.100y.com.tw)

Table 1
Pin Definitions and Functions (cont'd)

Symbol	Pin Number (P-MQFP-80)	I/O*	Function
P3.0-P3.7	15-22	I/O	<p>Port 3 is an 8-bit quasi-bidirectional I/O port with internal pullup resistors. Port 3 pins that have 1's written to them are pulled high by the internal pullup resistors, and in that state can be used as inputs. As inputs, port 3 pins being externally pulled low will source current (I_{IL}, in the DC characteristics) because of the internal pullup resistors. Port 3 also contains the interrupt, timer, serial port and external memory strobe pins that are used by various options. The output latch corresponding to a secondary function must be programmed to a one (1) for that function to operate. The secondary functions are assigned to the pins of port 3 as follows:</p>
	15		P3.0 / RxD Receiver data input (asynch.) or data input/output (synch.) of serial interface
	16		P3.1 / TxD Transmitter data output (asynch.) or clock output (synch.) of serial interface
	17		P3.2 / $\overline{INT0}$ External interrupt 0 input / timer 0 gate control input
	18		P3.3 / $\overline{INT1}$ External interrupt 1 input / timer 1 gate control input
	19		P3.4 / T0 Timer 0 counter input
	20		P3.5 / T1 Timer 1 counter input
	21		P3.6 / \overline{WR} \overline{WR} control output; latches the data byte from port 0 into the external data memory
	22		P3.7 / \overline{RD} \overline{RD} control output; enables the external data memory

*) I = Input
O = Output

Table 1
Pin Definitions and Functions (cont'd)

Symbol	Pin Number (P-MQFP-80)	I/O*	Function
P1.0 - P1.7	31-24	I/O	<p>Port 1 is an 8-bit quasi-bidirectional I/O port with internal pullup resistors. Port 1 pins that have 1's written to them are pulled high by the internal pullup resistors, and in that state can be used as inputs. As inputs, port 1 pins being externally pulled low will source current (I_{IL}, in the DC characteristics) because of the internal pullup resistors. The port is used for the low-order address byte during program verification. Port 1 also contains the interrupt, timer, clock, capture and compare pins that are used by various options. The output latch corresponding to a secondary function must be programmed to a one (1) for that function to operate (except when used for the compare functions). The secondary functions are assigned to the port 1 pins as follows :</p>
	31		P1.0 / $\overline{\text{INT3}}$ / CC0 Interrupt 3 input / compare 0 output / capture 0 input
	30		P1.1 / INT4 / CC1 Interrupt 4 input / compare 1 output / capture 1 input
	29		P1.2 / INT5 / CC2 Interrupt 5 input / compare 2 output / capture 2 input
	28		P1.3 / INT6 / CC3 Interrupt 6 input / compare 3 output / capture 3 input
	27		P1.4 / $\overline{\text{INT2}}$ Interrupt 2 input
	26		P1.5 / T2EX Timer 2 external reload / trigger input
	25		P1.6 / CLKOUT System clock output
	24		P1.7 / T2 Counter 2 input
V_{SS}	34	–	Ground (0 V)
V_{CC}	33, 69	–	Supply voltage during normal, idle, and power-down operation.

*) I = Input
O = Output

Table 1
Pin Definitions and Functions (cont'd)

Symbol	Pin Number (P-MQFP-80)	I/O*	Function
XTAL2	36	–	<p>XTAL2 Input to the inverting oscillator amplifier and input to the internal clock generator circuits. To drive the device from an external clock source, XTAL2 should be driven, while XTAL1 is left unconnected. Minimum and maximum high and low times as well as rise/fall times specified in the AC characteristics must be observed.</p>
XTAL1	37	–	<p>XTAL1 Output of the inverting oscillator amplifier.</p>
P2.0-P2.7	38-45	I/O	<p>Port 2 is an 8-bit quasi-bidirectional I/O port with internal pullup resistors. Port 2 pins that have 1's written to them are pulled high by the internal pullup resistors, and in that state can be used as inputs. As inputs, port 2 pins being externally pulled low will source current (I_{IL}, in the DC characteristics) because of the internal pullup resistors. Port 2 emits the high-order address byte during fetches from external program memory and during accesses to external data memory that use 16-bit addresses (MOVX @DPTR). In this application it uses strong internal pullup resistors when issuing 1's. During accesses to external data memory that use 8-bit addresses (MOVX @Ri), port 2 issues the contents of the P2 special function register.</p>
$\overline{\text{PSEN}}$	47	O	<p>The Program Store Enable output is a control signal that enables the external program memory to the bus during external fetch operations. It is activated every six oscillator periods, except during external data memory accesses. The signal remains high during internal program execution.</p>
ALE	48	O	<p>The Address Latch enable output is used for latching the address into external memory during normal operation. It is activated every six oscillator periods, except during an external data memory access.</p>

*) I = Input
O = Output

勝特力材料 886-3-5753170
 勝特力电子(上海) 86-21-54151736
 勝特力电子(深圳) 86-755-83298787
[Http://www.100y.com.tw](http://www.100y.com.tw)

Table 1
Pin Definitions and Functions (cont'd)

Symbol	Pin Number (P-MQFP-80)	I/O*	Function
\overline{EA}	49	I	External Access Enable When held high, the C515 executes instructions from the internal ROM (C515-1R) as long as the program counter is less than 2000 _H . When held low, the C515 fetches all instructions from ext. program memory. For the C515-L this pin must be tied low.
P0.0-P0.7	52-59	I/O	Port 0 is an 8-bit open-drain bidirectional I/O port. Port 0 pins that have 1's written to them float, and in that state can be used as high-impedance inputs. Port 0 is also the multiplexed low-order address and data bus during accesses to external program and data memory. In this application it uses strong internal pullup resistors when issuing 1's. Port 0 also outputs the code bytes during program verification in the C515-1R. External pullup resistors are required during program verification.
P5.3-P5.7	67-60	I/O	Port 5 is an 8-bit quasi-bidirectional I/O port with internal pullup resistors. Port 5 pins that have 1's written to them are pulled high by the internal pullup resistors, and in that state can be used as inputs. As inputs, port 5 pins being externally pulled low will source current (I_{IL} , in the DC characteristics) because of the internal pullup resistors.
P4.0-P4.7	72-74, 76-80	I/O	Port 4 is an 8-bit quasi-bidirectional I/O port with internal pull-up resistors. Port 4 pins that have 1's written to them are pulled high by the internal pull-up resistors, and in that state can be used as inputs. As inputs, port 4 pins being externally pulled low will source current (I_{IL} , in the DC characteristics) because of the internal pull-up resistors.
\overline{PE}	75	I	Power saving mode enable A low level on this pin allows the software to enter the power saving modes (idle mode and power down mode). When \overline{PE} is held at high level it is impossible to enter the power saving modes. When left unconnected this pin is pulled high by a weak internal pull-up resistor.

*) I = Input
O = Output

Table 1
Pin Definitions and Functions (cont'd)

Symbol	Pin Number (P-MQFP-80)	I/O*	Function
N.C.	2, 13, 14, 23, 32, 35, 46, 50, 51, 68, 70, 71	–	Not connected These pins of the P-MQFP-80 package must not be connected.

*) I = Input
O = Output

勝特力材料 886-3-5753170
 勝特力电子(上海) 86-21-54151736
 勝特力电子(深圳) 86-755-83298787
[Http://www.100y.com.tw](http://www.100y.com.tw)

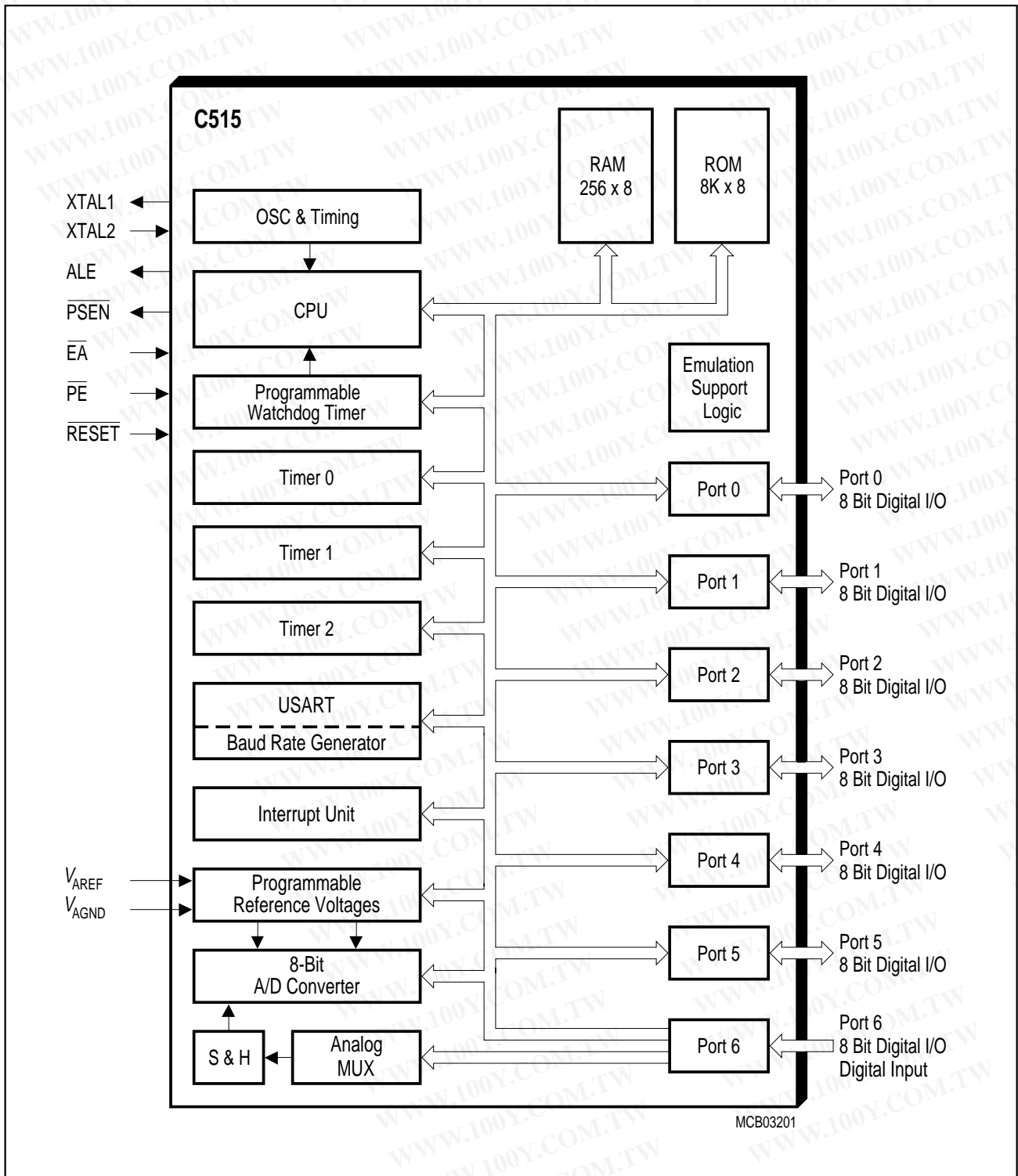

Figure 4
Block Diagram of the C515C

勝特力材料 886-3-5753170
 勝特力电子(上海) 86-21-54151736
 勝特力电子(深圳) 86-755-83298787
[Http://www.100y.com.tw](http://www.100y.com.tw)

CPU

The C515 is efficient both as a controller and as an arithmetic processor. It has extensive facilities for binary and BCD arithmetic and excels in its bit-handling capabilities. Efficient use of program memory results from an instruction set consisting of 44 % one-byte, 41 % two-byte, and 15% three-byte instructions. With a 6 MHz crystal, 58% of the instructions are executed in 1.0μs (10 MHz: 600).

Special Function Register PSW (Address D0_H)

Reset Value : 00_H

Bit No.	MSB							LSB	
	D7 _H	D6 _H	D5 _H	D4 _H	D3 _H	D2 _H	D1 _H	D0 _H	
D0 _H	CY	AC	F0	RS1	RS0	OV	F1	P	PSW

Bit	Function															
CY	Carry Flag Used by arithmetic instruction.															
AC	Auxiliary Carry Flag Used by instructions which execute BCD operations.															
F0	General Purpose Flag															
RS1 RS0	Register Bank select control bits These bits are used to select one of the four register banks.															
	<table border="1"> <thead> <tr> <th>RS1</th> <th>RS0</th> <th>Function</th> </tr> </thead> <tbody> <tr> <td>0</td> <td>0</td> <td>Bank 0 selected, data address 00_H-07_H</td> </tr> <tr> <td>0</td> <td>1</td> <td>Bank 1 selected, data address 08_H-0F_H</td> </tr> <tr> <td>1</td> <td>0</td> <td>Bank 2 selected, data address 10_H-17_H</td> </tr> <tr> <td>1</td> <td>1</td> <td>Bank 3 selected, data address 18_H-1F_H</td> </tr> </tbody> </table>	RS1	RS0	Function	0	0	Bank 0 selected, data address 00 _H -07 _H	0	1	Bank 1 selected, data address 08 _H -0F _H	1	0	Bank 2 selected, data address 10 _H -17 _H	1	1	Bank 3 selected, data address 18 _H -1F _H
RS1	RS0	Function														
0	0	Bank 0 selected, data address 00 _H -07 _H														
0	1	Bank 1 selected, data address 08 _H -0F _H														
1	0	Bank 2 selected, data address 10 _H -17 _H														
1	1	Bank 3 selected, data address 18 _H -1F _H														
OV	Overflow Flag Used by arithmetic instruction.															
F1	General Purpose Flag															
P	Parity Flag Set/cleared by hardware after each instruction to indicate an odd/even number of "one" bits in the accumulator, i.e. even parity.															

勝特力材料 886-3-5753170
 勝特力电子(上海) 86-21-54151736
 勝特力电子(深圳) 86-755-83298787
[Http://www.100y.com.tw](http://www.100y.com.tw)

Memory Organization

The C515 CPU manipulates data and operands in the following four address spaces:

- up to 64 Kbyte of internal/external program memory
- up to 64 Kbyte of external data memory
- 256 bytes of internal data memory
- a 128 byte special function register area

Figure 5 illustrates the memory address spaces of the C515.

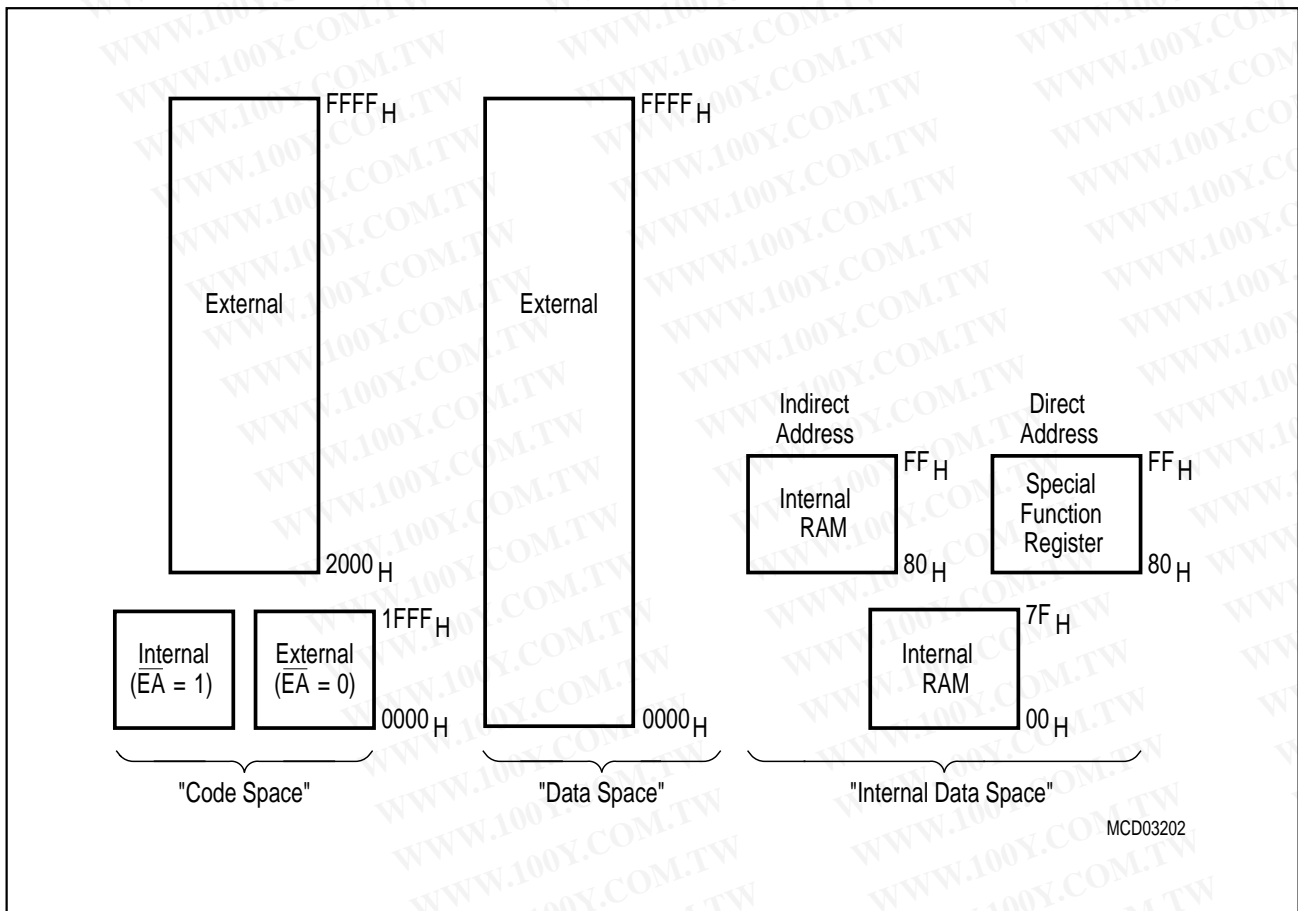

Figure 5
C515 Memory Map

勝特力材料 886-3-5753170
 勝特力电子(上海) 86-21-54151736
 勝特力电子(深圳) 86-755-83298787
[Http://www.100y.com.tw](http://www.100y.com.tw)

Reset and System Clock

The reset input is an active low input at pin $\overline{\text{RESET}}$. Since the reset is synchronized internally, the $\overline{\text{RESET}}$ pin must be held low for at least two machine cycles (24 oscillator periods) while the oscillator is running. A pullup resistor is internally connected to V_{CC} to allow a power-up reset with an external capacitor only. An automatic reset can be obtained when V_{CC} is applied by connecting the $\overline{\text{RESET}}$ pin to V_{SS} via a capacitor. **Figure 6** shows the possible reset circuitries.

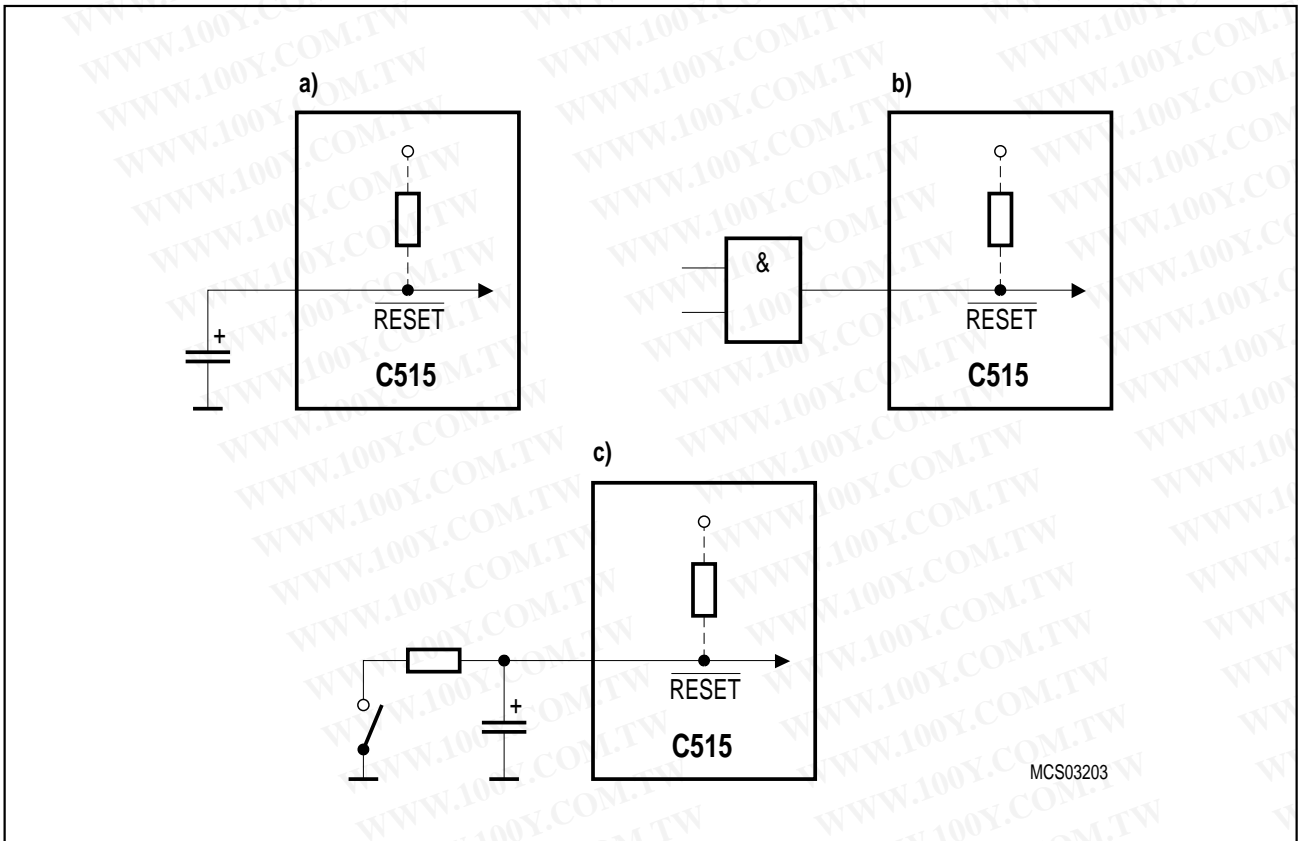

Figure 6
Reset Circuitries

勝特力材料 886-3-5753170
 勝特力电子(上海) 86-21-54151736
 勝特力电子(深圳) 86-755-83298787
[Http://www.100y.com.tw](http://www.100y.com.tw)

Figure 7 shows the recommended oscillator circuitries for crystal and external clock operation.

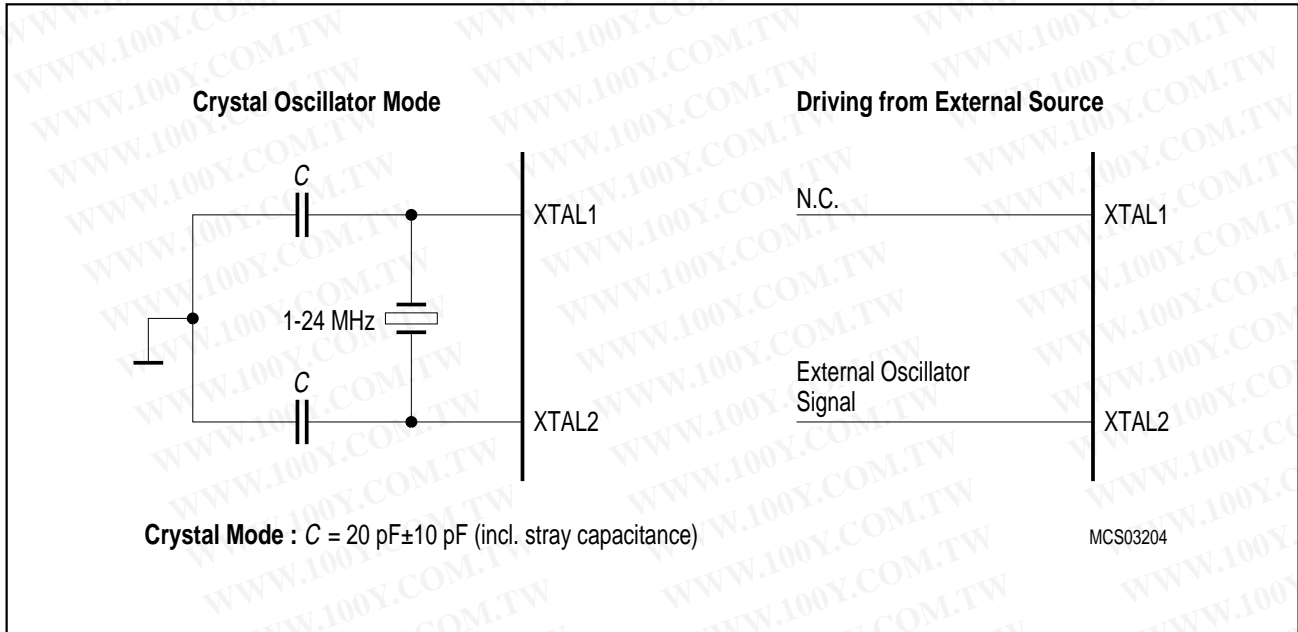

Figure 7
Recommended Oscillator Circuitries

勝特力材料 886-3-5753170
 勝特力电子(上海) 86-21-54151736
 勝特力电子(深圳) 86-755-83298787
[Http://www.100y.com.tw](http://www.100y.com.tw)

Enhanced Hooks Emulation Concept

The Enhanced Hooks Emulation Concept of the C500 microcontroller family is a new, innovative way to control the execution of C500 MCUs and to gain extensive information on the internal operation of the controllers. Emulation of on-chip ROM based programs is possible, too.

Each production chip has built-in logic for the support of the Enhanced Hooks Emulation Concept. Therefore, no costly bond-out chips are necessary for emulation. This also ensure that emulation and production chips are identical.

The Enhanced Hooks Technology™¹⁾, which requires embedded logic in the C500 allows the C500 together with an EH-IC to function similar to a bond-out chip. This simplifies the design and reduces costs of an ICE-system. ICE-systems using an EH-IC and a compatible C500 are able to emulate all operating modes of the different versions of the C500 microcontrollers. This includes emulation of ROM, ROM with code rollover and ROMless modes of operation. It is also able to operate in single step mode and to read the SFRs after a break.

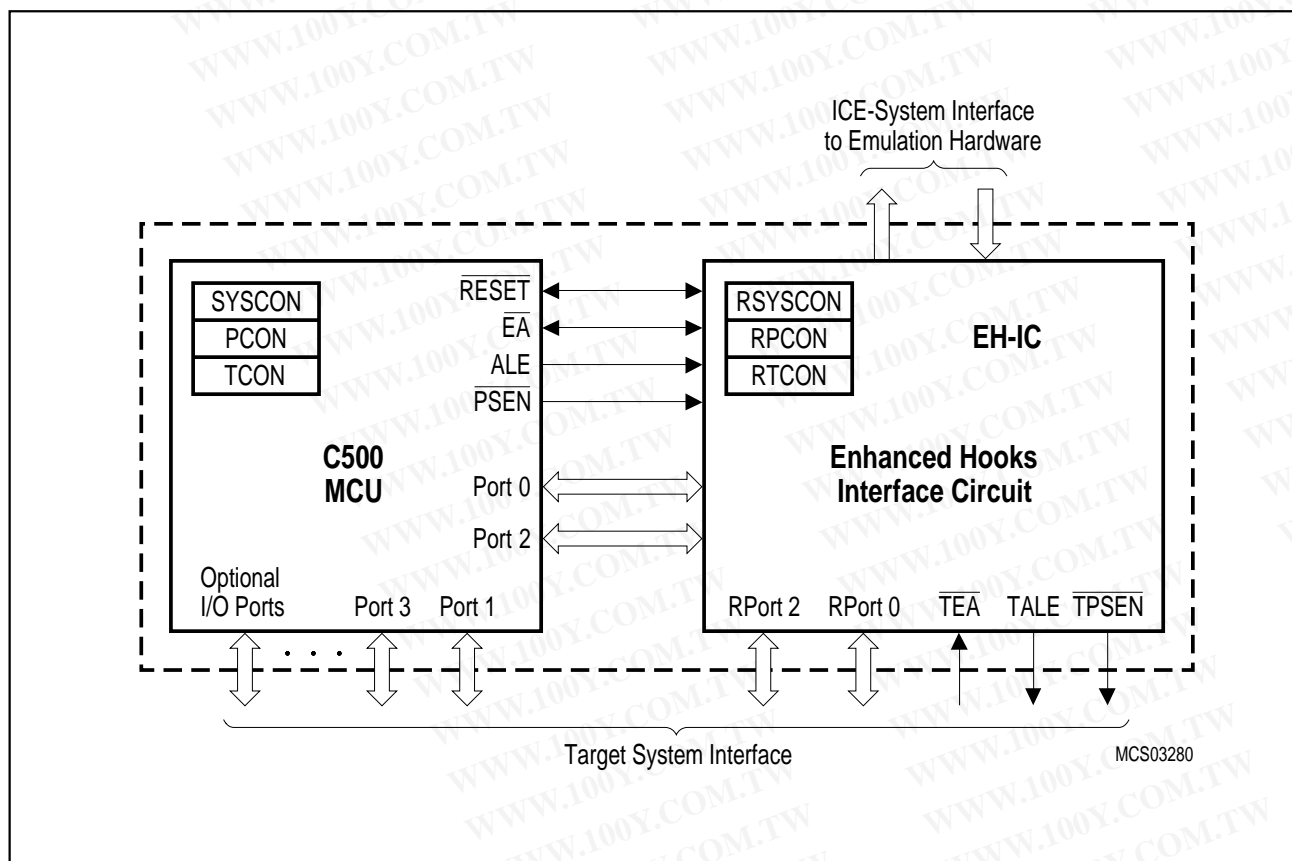

Figure 8
Basic C500 MCU Enhanced Hooks Concept Configuration

Port 0, port 2 and some of the control lines of the C500 based MCU are used by Enhanced Hooks Emulation Concept to control the operation of the device during emulation and to transfer informations about the programm execution and data transfer between the external emulation hardware (ICE-system) and the C500 MCU.

1 "Enhanced Hooks Technology" is a trademark and patent of Metalink Corporation licensed to Siemens.

Special Function Registers

The registers, except the program counter and the four general purpose register banks, reside in the special function register area.

The 59 special function registers (SFRs) include pointers and registers that provide an interface between the CPU and the other on-chip peripherals. All SFRs with addresses where address bits 0-2 are 0 (e.g. 80_H, 88_H, 90_H, 98_H, ..., F8_H, FF_H) are bitaddressable.

The SFRs of the C515 are listed in **table 2** and **table 3**. In **table 2** they are organized in groups which refer to the functional blocks of the C515. **Table 3** illustrates the contents of the SFRs in numeric order of their addresses.

勝特力材料 886-3-5753170
勝特力电子(上海) 86-21-54151736
勝特力电子(深圳) 86-755-83298787
[Http://www.100y.com.tw](http://www.100y.com.tw)

Table 2
Special Function Registers - Functional Blocks

Block	Symbol	Name	Address	Contents after Reset
CPU	ACC	Accumulator	E0H ¹⁾	00H
	B	B-Register	F0H ¹⁾	00H
	DPH	Data Pointer, High Byte	83H	00H
	DPL	Data Pointer, Low Byte	82H	00H
	PSW	Program Status Word Register	D0H ¹⁾	00H
	SP	Stack Pointer	81H	07H
	SYSCON	System Control Register	B1H	XX1X XXXXB ³⁾
	A/D- Converter	ADCON ²⁾	A/D Converter Control Register	D8H ¹⁾
ADDAT		A/D Converter Data Register	D9H	00H
DAPR		A/D Converter Program Register	DAH ⁴⁾	00H
Interrupt System	IEN0 ²⁾	Interrupt Enable Register 0	A8H ¹⁾	00H
	IEN1 ²⁾	Interrupt Enable Register 1	B8H ¹⁾	00H
	IP0 ²⁾	Interrupt Priority Register 0	A9H	X000 0000B ³⁾
	IP1	Interrupt Priority Register 1	B9H	XX00 0000B ³⁾
	IRCON	Interrupt Request Control Register	C0H ¹⁾	00H
	TCON ²⁾	Timer Control Register	88H ¹⁾	00H
	T2CON ²⁾	Timer 2 Control Register	C8H ¹⁾	00H
	SCON ²⁾	Serial Channel Control Register	98H ¹⁾	00H
Timer 0/ Timer 1	TCON ²⁾	Timer 0/1 Control Register	88H ¹⁾	00H
	TH0	Timer 0, High Byte	8CH	00H
	TH1	Timer 1, High Byte	8DH	00H
	TL0	Timer 0, Low Byte	8AH	00H
	TL1	Timer 1, Low Byte	8BH	00H
	TMOD	Timer Mode Register	89H	00H
	Compare/ Capture Unit / Timer 2	CCEN	Comp./Capture Enable Reg.	C1H
CCH1		Comp./Capture Reg. 1, High Byte	C3H	00H
CCH2		Comp./Capture Reg. 2, High Byte	C5H	00H
CCH3		Comp./Capture Reg. 3, High Byte	C7H	00H
CCL1		Comp./Capture Reg. 1, Low Byte	C2H	00H
CCL2		Comp./Capture Reg. 2, Low Byte	C4H	00H
CCL3		Comp./Capture Reg. 3, Low Byte	C6H	00H
CRCH		Com./Rel./Capt. Reg. High Byte	CBH	00H
CRCL		Com./Rel./Capt. Reg. Low Byte	CAH	00H
TH2		Timer 2, High Byte	CDH	00H
TL2		Timer 2, Low Byte	CCH	00H
T2CON ²⁾		Timer 2 Control Register	C8H ¹⁾	00H

1) Bit-addressable special function registers

2) This special function register is listed repeatedly since some bits of it also belong to other functional blocks.

3) "X" means that the value is undefined and the location is reserved

Table 2
Special Function Registers - Functional Blocks (cont'd)

Block	Symbol	Name	Address	Contents after Reset
Ports	P0	Port 0	80H ¹⁾	FFH
	P1	Port 1	90H ¹⁾	FFH
	P2	Port 2	A0H ¹⁾	FFH
	P3	Port 3	B0H ¹⁾	FFH
	P4	Port 4	E8H ¹⁾	FFH
	P5	Port 5	F8H ¹⁾	FFH
	P6	Port 6, Analog/Digital Input	DBH	–
Serial Channel	ADCON ²⁾	A/D Converter Control Register	D8H ¹⁾	00X0 0000B ³⁾
	PCON ²⁾	Power Control Register	87H	00H
	SBUF	Serial Channel Buffer Register	99H	XXH ³⁾
	SCON ²⁾	Serial Channel Control Register	98H ¹⁾	00H
Watchdog	IEN0 ²⁾	Interrupt Enable Register 0	A8H ¹⁾	00H
	IEN1 ²⁾	Interrupt Enable Register 1	B8H ¹⁾	00H
	IPO ²⁾	Interrupt Priority Register 0	A9H	X000 0000B ³⁾
Power Saving Modes	PCON ²⁾	Power Control Register	87H	00H

1) Bit-addressable special function registers

2) This special function register is listed repeatedly since some bits of it also belong to other functional blocks.

3) "X" means that the value is undefined and the location is reserved

勝特力材料 886-3-5753170
 勝特力电子(上海) 86-21-54151736
 勝特力电子(深圳) 86-755-83298787
[Http://www.100y.com.tw](http://www.100y.com.tw)

Table 3
Contents of the SFRs, SFRs in numeric order of their addresses

Addr	Register	Content after Reset ¹⁾	Bit 7	Bit 6	Bit 5	Bit 4	Bit 3	Bit 2	Bit 1	Bit 0
80 _H ²⁾	P0	FF _H	.7	.6	.5	.4	.3	.2	.1	.0
81 _H	SP	07 _H	.7	.6	.5	.4	.3	.2	.1	.0
82 _H	DPL	00 _H	.7	.6	.5	.4	.3	.2	.1	.0
83 _H	DPH	00 _H	.7	.6	.5	.4	.3	.2	.1	.0
87 _H	PCON	00 _H	SMOD	PDS	IDLS	SD	GF1	GF0	PDE	IDLE
88 _H ²⁾	TCON	00 _H	TF1	TR1	TF0	TR0	IE1	IT1	IE0	IT0
89 _H	TMOD	00 _H	GATE	C/ \bar{T}	M1	M0	GATE	C/ \bar{T}	M1	M0
8A _H	TL0	00 _H	.7	.6	.5	.4	.3	.2	.1	.0
8B _H	TL1	00 _H	.7	.6	.5	.4	.3	.2	.1	.0
8C _H	TH0	00 _H	.7	.6	.5	.4	.3	.2	.1	.0
8D _H	TH1	00 _H	.7	.6	.5	.4	.3	.2	.1	.0
90 _H ²⁾	P1	FF _H	T2	CLK-OUT	T2EX	$\bar{INT}2$	INT6	INT5	INT4	$\bar{INT}3$
98 _H ²⁾	SCON	00 _H	SM0	SM1	SM2	REN	TB8	RB8	TI	RI
99 _H	SBUF	XX _H	.7	.6	.5	.4	.3	.2	.1	.0
A0 _H ²⁾	P2	FF _H	.7	.6	.5	.4	.3	.2	.1	.0
A8 _H ²⁾	IEN0	00 _H	EAL	WDT	ET2	ES	ET1	EX1	ET0	EX0
A9 _H	IP0	X000-0000 _B	–	WDTS	.5	.4	.3	.2	.1	.0
B0 _H ²⁾	P3	FF _H	RD	WR	T1	T0	INT1	INT0	TxD	RxD
B1 _H	SYSCON	XX1X-XXXX _B	–	–	EALE	–	–	–	–	–
B8 _H ²⁾	IEN1	00 _H	EXEN2	SWDT	EX6	EX5	EX4	EX3	EX2	EADC
B9 _H	IP1	XX00-0000 _B	–	–	.5	.4	.3	.2	.1	.0
C0 _H ²⁾	IRCON	00 _H	EXF2	TF2	IEX6	IEX5	IEX4	IEX3	IEX2	IADC
C1 _H	CCEN	00 _H	COCA H3	COCAL 3	COCA H2	COCAL 2	COCA H1	COCAL 1	COCA H0	COCAL 0
C2 _H	CCL1	00 _H	.7	.6	.5	.4	.3	.2	.1	.0

1) X means that the value is undefined and the location is reserved

2) Bit-addressable special function registers

Table 3
Contents of the SFRs, SFRs in numeric order of their addresses (cont'd)

Addr	Register	Content after Reset ¹⁾	Bit 7	Bit 6	Bit 5	Bit 4	Bit 3	Bit 2	Bit 1	Bit 0
C3 _H	CCH1	00 _H	.7	.6	.5	.4	.3	.2	.1	.0
C4 _H	CCL2	00 _H	.7	.6	.5	.4	.3	.2	.1	.0
C5 _H	CCH2	00 _H	.7	.6	.5	.4	.3	.2	.1	.0
C6 _H	CCL3	00 _H	.7	.6	.5	.4	.3	.2	.1	.0
C7 _H	CCH3	00 _H	.7	.6	.5	.4	.3	.2	.1	.0
C8 _H ²⁾	T2CON	00 _H	T2PS	I3FR	I2FR	T2R1	T2R0	T2CM	T2I1	T2I0
CA _H	CRCL	00 _H	.7	.6	.5	.4	.3	.2	.1	.0
CB _H	CRCH	00 _H	.7	.6	.5	.4	.3	.2	.1	.0
CC _H	TL2	00 _H	.7	.6	.5	.4	.3	.2	.1	.0
CD _H	TH2	00 _H	.7	.6	.5	.4	.3	.2	.1	.0
D0 _H ²⁾	PSW	00 _H	CY	AC	F0	RS1	RS0	OV	F1	P
D8 _H ²⁾	ADCON	00X0-0000 _B	BD	CLK	–	BSY	ADM	MX2	MX1	MX0
D9 _H	ADDAT	00 _H	.7	.6	.5	.4	.3	.2	.1	.0
DA _H	DAPR	00 _H	.7	.6	.5	.4	.3	.2	.1	.0
DB _H	P6	–	.7	.6	.5	.4	.3	.2	.1	.0
E0 _H ²⁾	ACC	00 _H	.7	.6	.5	.4	.3	.2	.1	.0
E8 _H ²⁾	P4	FF _H	.7	.6	.5	.4	.3	.2	.1	.0
F0 _H ²⁾	B	00 _H	.7	.6	.5	.4	.3	.2	.1	.0
F8 _H ²⁾	P5	FF _H	.7	.6	.5	.4	.3	.2	.1	.0

1) X means that the value is undefined and the location is reserved

2) Bit-addressable special function registers

勝特力材料 886-3-5753170
勝特力电子(上海) 86-21-54151736
勝特力电子(深圳) 86-755-83298787
[Http://www.100y.com.tw](http://www.100y.com.tw)

Digital I/O Ports

The C515 allows for digital I/O on 48 lines grouped into 6 bidirectional 8-bit ports. Each port bit consists of a latch, an output driver and an input buffer. Read and write accesses to the I/O ports P0 through P5 are performed via their corresponding special function registers P0 to P5.

The output drivers of port 0 and 2 and the input buffers of port 0 are also used for accessing external memory. In this application, port 0 outputs the low byte of the external memory address, time-multiplexed with the byte being written or read. Port 2 outputs the high byte of the external memory address when the address is 16 bits wide. Otherwise, the port 2 pins continue emitting the P2 SFR contents.

Analog Input Ports

Port 6 is available as input port only and provides two functions. When used as digital inputs, the corresponding SFR P6 contains the digital value applied to the port 6 lines. When used for analog inputs the desired analog channel is selected by a three-bit field in SFR ADCON. Of course, it makes no sense to output a value to these input-only ports by writing to the SFR P6. This will have no effect.

If a digital value is to be read, the voltage levels are to be held within the input voltage specifications (V_{IL}/V_{IH}). Since P6 is not bit-addressable, all input lines of P6 are read at the same time by byte instructions.

Nevertheless, it is possible to use port 6 simultaneously for analog and digital input. However, care must be taken that all bits of P6 that have an undetermined value caused by their analog function are masked.

勝特力材料 886-3-5753170
勝特力电子(上海) 86-21-54151736
勝特力电子(深圳) 86-755-83298787
[Http://www.100y.com.tw](http://www.100y.com.tw)

Timer / Counter 0 and 1

Timer/Counter 0 and 1 can be used in four operating modes as listed in **table 4** :

Table 4
Timer/Counter 0 and 1 Operating Modes

Mode	Description	TMOD		Input Clock	
		M1	M0	internal	external (max)
0	8-bit timer/counter with a divide-by-32 prescaler	0	0	$f_{osc}/12 \times 32$	$f_{osc}/24 \times 32$
1	16-bit timer/counter	1	1	$f_{osc}/12$	$f_{osc}/24$
2	8-bit timer/counter with 8-bit autoreload	1	0		
3	Timer/counter 0 used as one 8-bit timer/counter and one 8-bit timer Timer 1 stops	1	1		

In the “timer” function ($C/\bar{T} = '0'$) the register is incremented every machine cycle. Therefore the count rate is $f_{osc}/12$.

In the “counter” function the register is incremented in response to a 1-to-0 transition at its corresponding external input pin (P3.4/T0, P3.5/T1). Since it takes two machine cycles to detect a falling edge the max. count rate is $f_{osc}/24$. External inputs $\overline{INT0}$ and $\overline{INT1}$ (P3.2, P3.3) can be programmed to function as a gate to facilitate pulse width measurements. **Figure 9** illustrates the input clock logic.

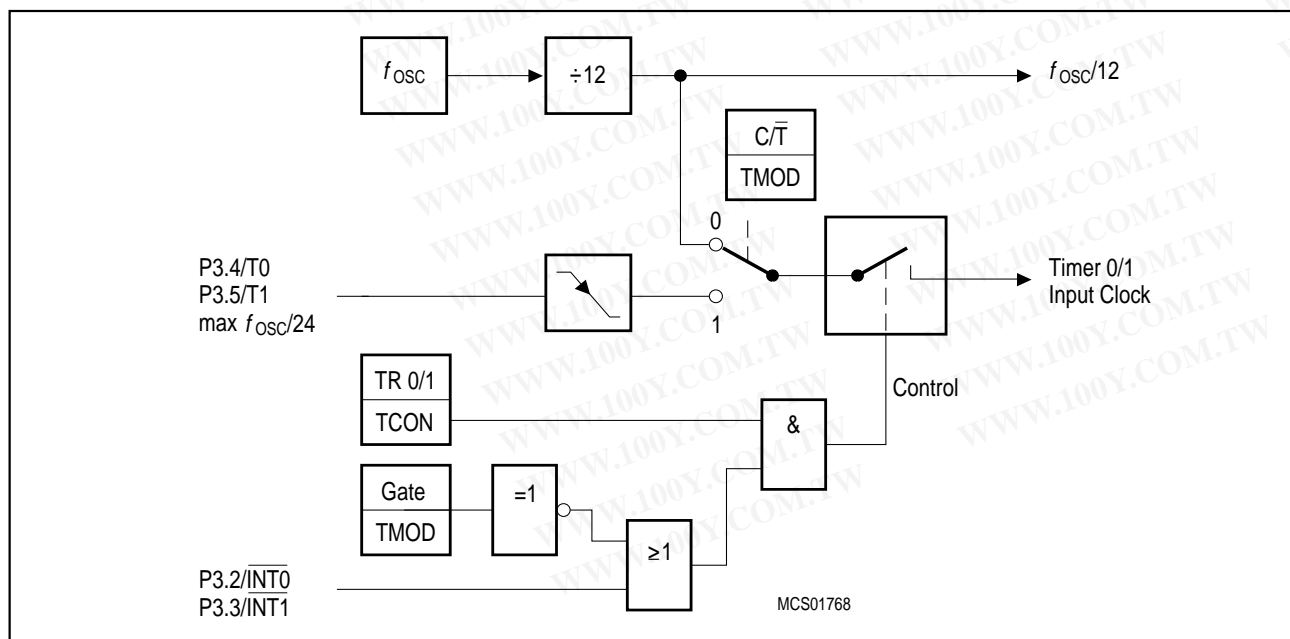

Figure 9
Timer/Counter 0 and 1 Input Clock Logic

Timer/Counter 2 with Compare/Capture/Reload

The timer 2 of the C515 provides additional compare/capture/reload features. which allow the selection of the following operating modes:

- Compare : up to 4 PWM signals with 16-bit/500 ns resolution
- Capture : up to 4 high speed capture inputs with 500 ns resolution
- Reload : modulation of timer 2 cycle time

The block diagram in **figure 10** shows the general configuration of timer 2 with the additional compare/capture/reload registers. The I/O pins which can be used for timer 2 control are located as multifunctional port functions at port 1.

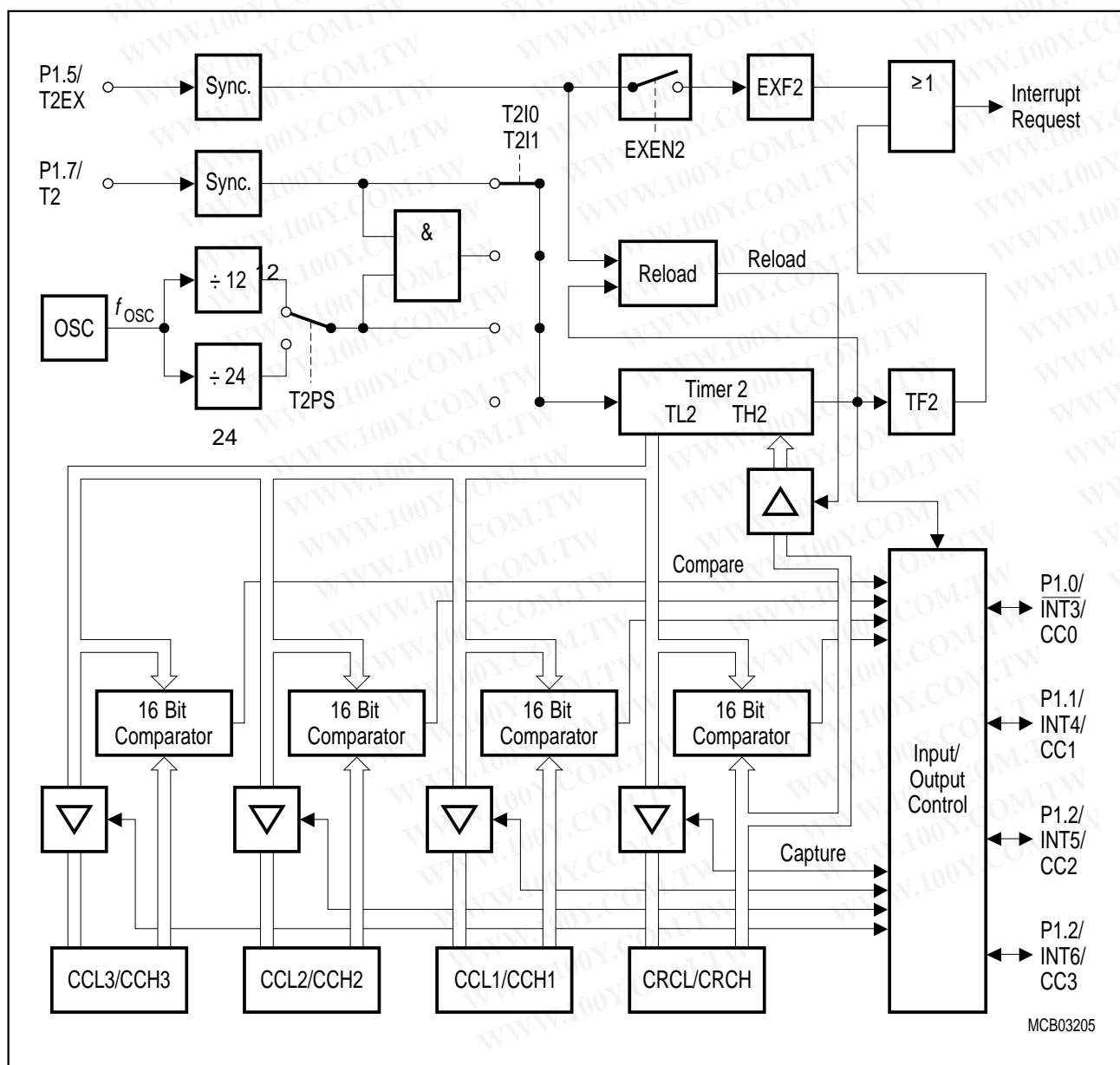

Figure 10
Timer 2 Block Diagram

Timer 2 Operating Modes

The timer 2, which is a 16-bit-wide register, can operate as timer, event counter, or gated timer. A roll-over of the count value in TL2/TH2 from all 1's to all 0's sets the timer overflow flag TF2 in SFR IRCON, which can generate an interrupt. The bits in register T2CON are used to control the timer 2 operation.

Timer Mode: In timer function, the count rate is derived from the oscillator frequency. A prescaler offers the possibility of selecting a count rate of 1/12 or 1/24 of the oscillator frequency.

Gated Timer Mode: In gated timer function, the external input pin T2 (P1.7) functions as a gate to the input of timer 2. If T2 is high, the internal clock input is gated to the timer. T2 = 0 stops the counting procedure. This facilitates pulse width measurements. The external gate signal is sampled once every machine cycle.

Event Counter Mode: In the event counter function, the timer 2 is incremented in response to a 1-to-0 transition at its corresponding external input pin T2 (P1.7). In this function, the external input is sampled every machine cycle. Since it takes two machine cycles (24 oscillator periods) to recognize a 1-to-0 transition, the maximum count rate is 1/24 of the oscillator frequency. There are no restrictions on the duty cycle of the external input signal, but to ensure that a given level is sampled at least once before it changes, it must be held for at least one full machine cycle.

Reload of Timer 2: Two reload modes are selectable:

In mode 0, when timer 2 rolls over from all 1's to all 0's, it not only sets TF2 but also causes the timer 2 registers to be loaded with the 16-bit value in the CRC register, which is preset by software.

In mode 1, a 16-bit reload from the CRC register is caused by a negative transition at the corresponding input pin P1.5/T2EX. This transition will also set flag EXF2 if bit EXEN2 in SFR IEN1 has been set.

勝特力材料 886-3-5753170
勝特力电子(上海) 86-21-54151736
勝特力电子(深圳) 86-755-83298787
[Http://www.100y.com.tw](http://www.100y.com.tw)

Timer 2 Compare Modes

The compare function of a timer/register combination operates as follows : the 16-bit value stored in a compare or compare/capture register is compared with the contents of the timer register; if the count value in the timer register matches the stored value, an appropriate output signal is generated at a corresponding port pin and an interrupt can be generated.

Compare Mode 0

In compare mode 0, upon matching the timer and compare register contents, the output signal changes from low to high. It goes back to a low level on timer overflow. As long as compare mode 0 is enabled, the appropriate output pin is controlled by the timer circuit only and writing to the port will have no effect. **Figure 11** shows a functional diagram of a port circuit when used in compare mode 0. The port latch is directly controlled by the timer overflow and compare match signals. The input line from the internal bus and the write-to-latch line of the port latch are disconnected when compare mode 0 is enabled.

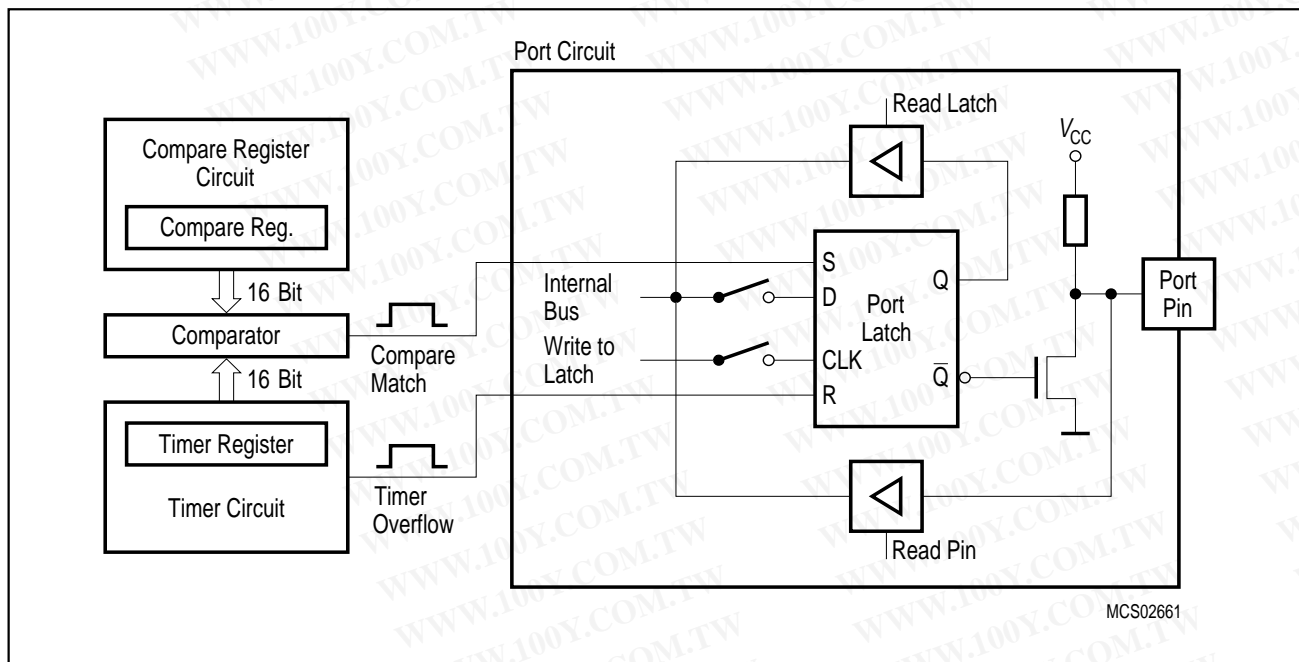

Figure 11
Port Latch in Compare Mode 0

勝特力材料 886-3-5753170
 勝特力电子(上海) 86-21-54151736
 勝特力电子(深圳) 86-755-83298787
[Http://www.100y.com.tw](http://www.100y.com.tw)

Compare Mode 1

If compare mode 1 is enabled and the software writes to the appropriate output latch at the port, the new value will not appear at the output pin until the next compare match occurs. Thus, it can be chosen whether the output signal has to make a new transition (1-to-0 or 0-to-1, depending on the actual pin-level) or should keep its old value at the time when the timer value matches the stored compare value.

In compare mode 1 (see **figure 12**) the port circuit consists of two separate latches. One latch (which acts as a "shadow latch") can be written under software control, but its value will only be transferred to the port latch (and thus to the port pin) when a compare match occurs.

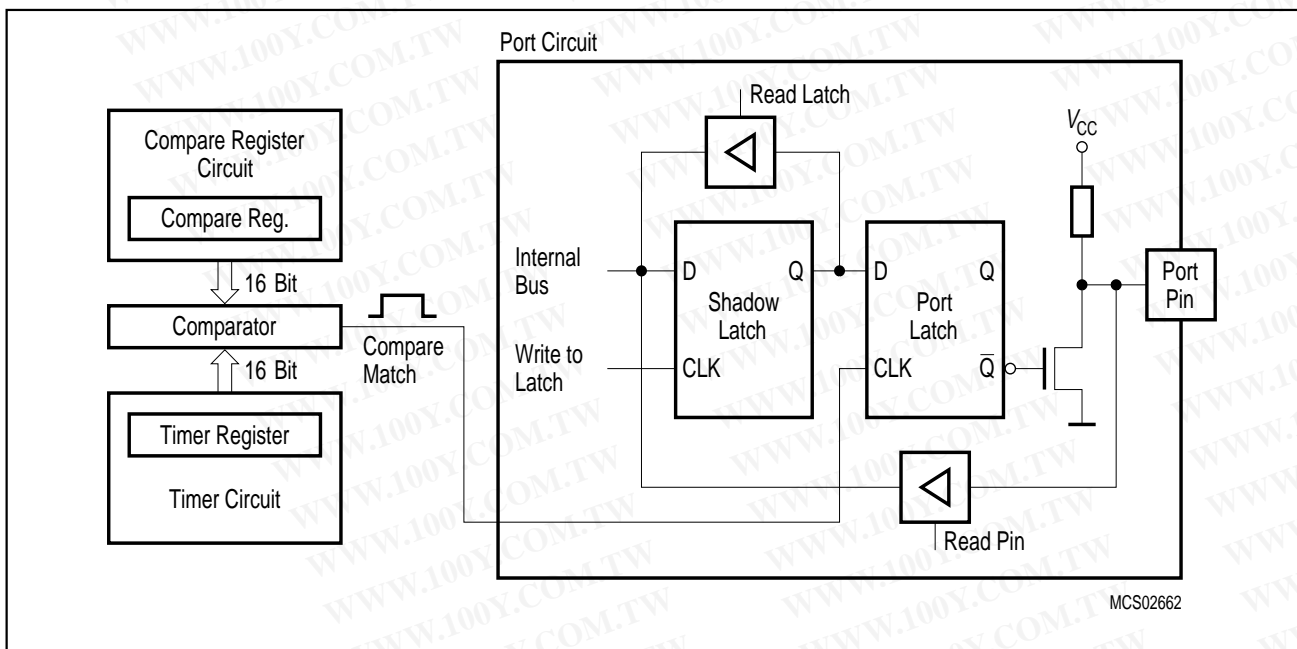

Figure 12
Compare Function in Compare Mode 1

勝特力材料 886-3-5753170
 勝特力电子(上海) 86-21-54151736
 勝特力电子(深圳) 86-755-83298787
[Http://www.100y.com.tw](http://www.100y.com.tw)

Serial Interface (USART)

The serial port is full duplex and can operate in four modes (one synchronous mode, three asynchronous modes) as illustrated in **table 5**. The possible baudrates can be calculated using the formulas given in **table 5**.

Table 5
USART Operating Modes

Mode	SCON		Description
	SM0	SM1	
0	0	0	Shift register mode Serial data enters and exits through RxD/ TxD outputs the shift clock; 8-bit are transmitted/received (LSB first); fixed baud rate
1	0	1	8-bit UART, variable baud rate 10 bits are transmitted (through TxD) or received (at RxD)
2	1	0	9-bit UART, fixed baud rate 11 bits are transmitted (through TxD) or received (at RxD)
3	1	1	9-bit UART, variable baud rate Like mode 2

For clarification some terms regarding the difference between "baud rate clock" and "baud rate" should be mentioned. In the asynchronous modes the serial interfaces require a clock rate which is 16 times the baud rate for internal synchronization. Therefore, the baud rate generators/timers have to provide a "baud rate clock" (output signal in **figure 13** to the serial interface which - there divided by 16 - results in the actual "baud rate". Further, the abbreviation f_{OSC} refers to the oscillator frequency (crystal or external clock operation).

The variable baud rates for modes 1 and 3 of the serial interface can be derived from either timer 1 or from the system clock (see **figure 13**).

勝特力材料 886-3-5753170
 勝特力电子(上海) 86-21-54151736
 勝特力电子(深圳) 86-755-83298787
[Http://www.100y.com.tw](http://www.100y.com.tw)

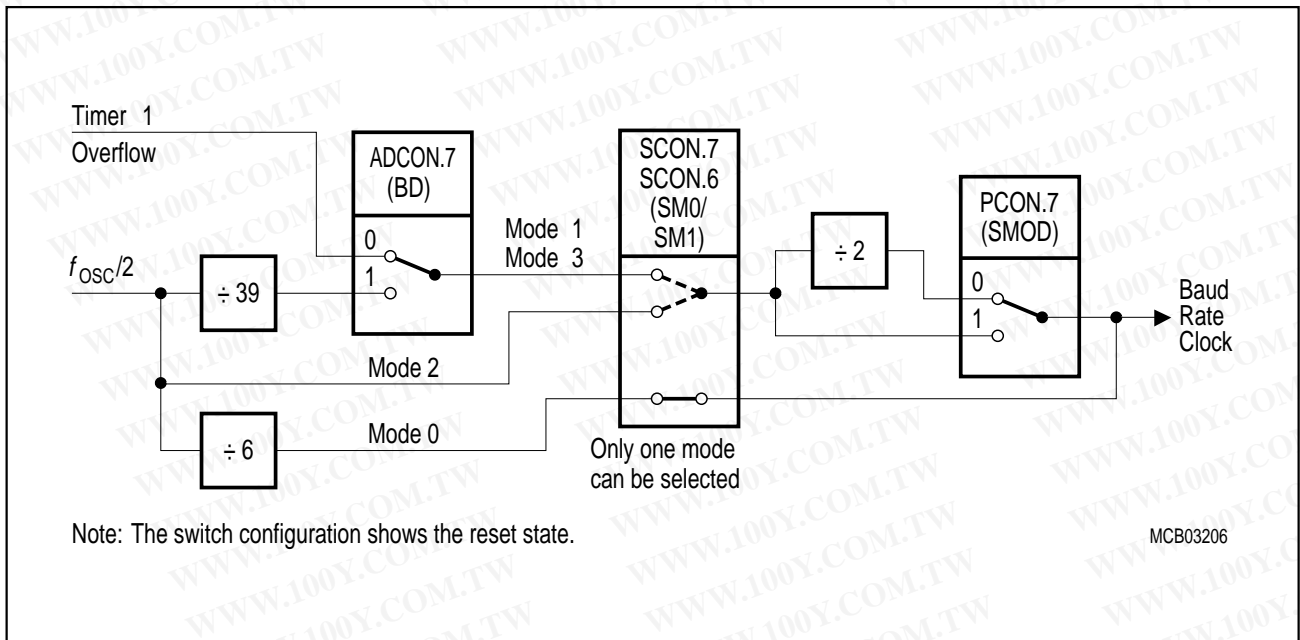

Figure 13
Block Diagram of Baud Rate Generation for the Serial Interface

Table 6 below lists the values/formulas for the baud rate calculation of the serial interface with its dependencies of the control bits BD and SMOD.

Table 6
Serial Interface - Baud Rate Dependencies

Serial Interface 0 Operating Modes	Active Control Bits		Baud Rate Calculation
	BD	SMOD	
Mode 0 (Shift Register)	—	—	$f_{osc} / 12$
Mode 1 (8-bit UART) Mode 3 (9-bit UART)	0	X	Controlled by timer 1 overflow : $(2^{SMOD} \times \text{timer 1 overflow rate}) / 32$
	1	X	Controlled by system clock divider circuits : $(2^{SMOD} \times f_{osc}) / 2496$
Mode 2 (9-bit UART)	—	0	$f_{osc} / 64$
		1	$f_{osc} / 32$

勝特力材料 886-3-5753170
 勝特力电子(上海) 86-21-54151736
 勝特力电子(深圳) 86-755-83298787
[Http://www.100y.com.tw](http://www.100y.com.tw)

8-Bit A/D Converter

The C515 provides an A/D converter with the following features:

- Eight multiplexed input channels
- The possibility of using the analog inputs (port 6) also as digital inputs
- Programmable internal reference voltages (16 steps each) via resistor array
- 8-bit resolution within the selected reference voltage range
- Internal start-of-conversion trigger
- Interrupt request generation after each conversion

For the A/D conversion, the method of successive approximation via capacitor array is used. The externally applied reference voltage range has to be held on a fixed value within the specifications (see section "A/D Converter Characteristics" in this data sheet). The internal reference voltages can be varied to reduce the reference voltage range of the A/D converter and thus to achieve a higher resolution. **Figure 14** shows a block diagram of the A/D converter.

勝特力材料 886-3-5753170
勝特力电子(上海) 86-21-54151736
勝特力电子(深圳) 86-755-83298787
[Http://www.100y.com.tw](http://www.100y.com.tw)

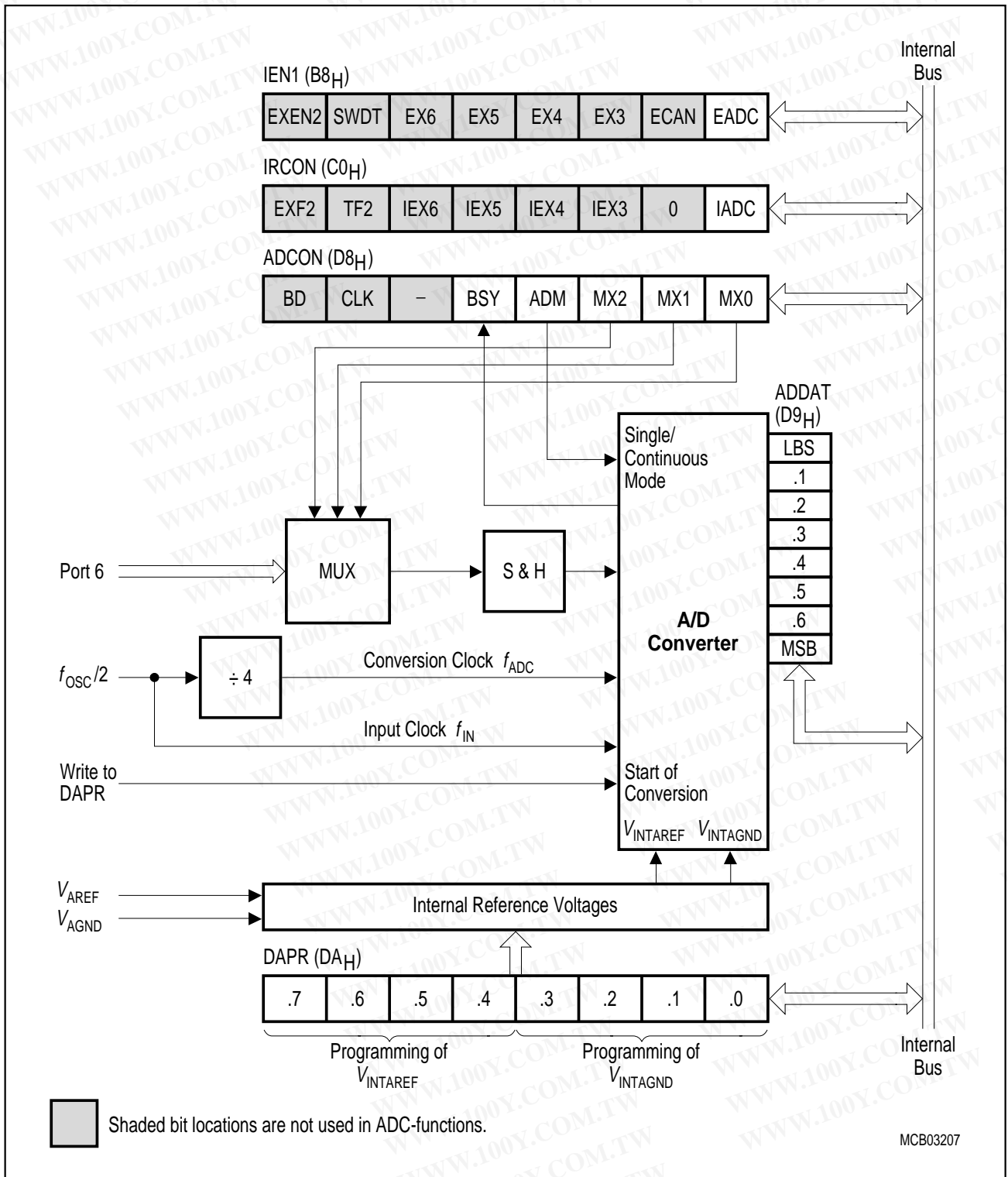

Figure 14
A/D Converter Block Diagram

勝特力材料 886-3-5753170
 勝特力电子(上海) 86-21-54151736
 勝特力电子(深圳) 86-755-83298787
[Http://www.100y.com.tw](http://www.100y.com.tw)

Interrupt System

The C515 provides 12 interrupt sources with four priority levels. Five interrupts can be generated by the on-chip peripherals (timer 0, timer 1, timer 2, A/D converter, and serial interface) and seven interrupts may be triggered externally (P3.2/ $\overline{\text{INT0}}$, P3.3/ $\overline{\text{INT1}}$, P1.4/ $\overline{\text{INT2}}$, P1.0/ $\overline{\text{INT3}}$, P1.1/ $\overline{\text{INT4}}$, P1.2/ $\overline{\text{INT5}}$, P1.3/ $\overline{\text{INT6}}$).

This chapter shows the interrupt structure, the interrupt vectors and the interrupt related special function registers. **Figure 15** and **16** give a general overview of the interrupt sources and illustrate the request and the control flags which are described in the next sections.

勝特力材料 886-3-5753170
勝特力電子 86-755-83298787
[Http://www.100y.com.tw](http://www.100y.com.tw)

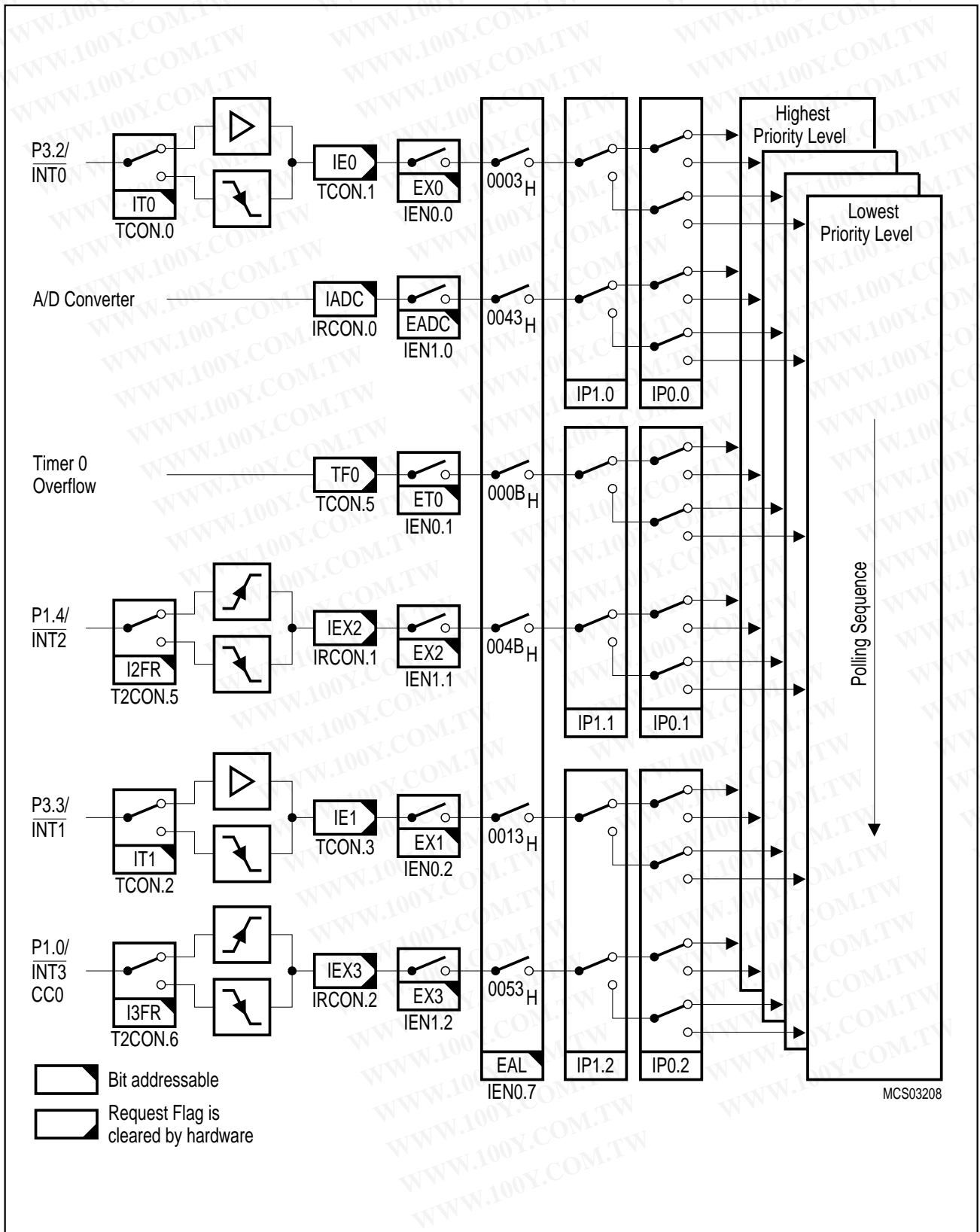

Figure 15
 Interrupt Request Sources (Part 1)

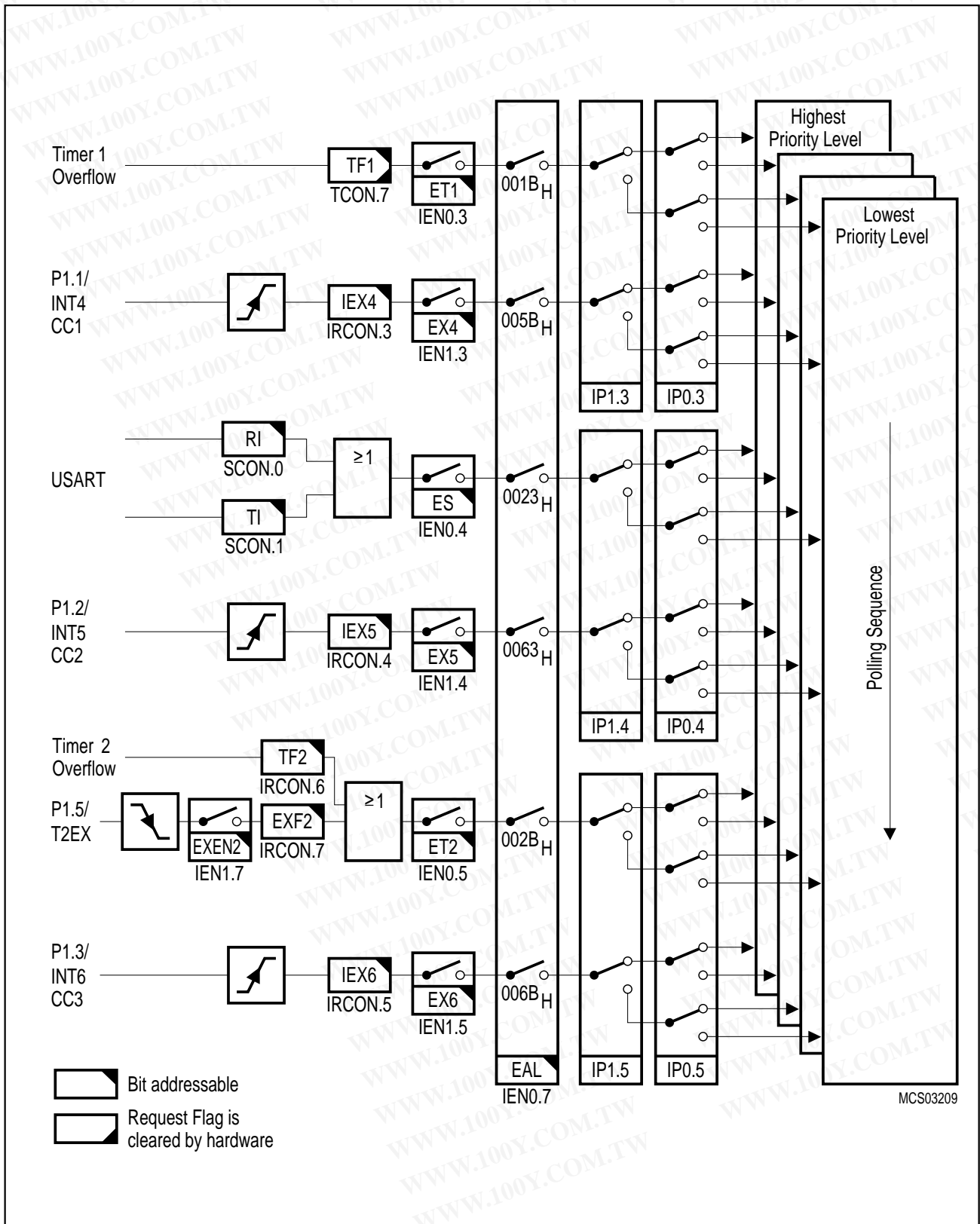

Figure 16
 Interrupt Request Sources (Part 2)

Table 7
Interrupt Source and Vectors

Interrupt Source	Interrupt Vector Address	Interrupt Request Flags
External Interrupt 0	0003 _H	IE0
Timer 0 Overflow	000B _H	TF0
External Interrupt 1	0013 _H	IE1
Timer 1 Overflow	001B _H	TF1
Serial Channel	0023 _H	RI / TI
Timer 2 Overflow / Ext. Reload	002B _H	TF2 / EXF2
A/D Converter	0043 _H	IADC
External Interrupt 2	004B _H	IEX2
External Interrupt 3	0053 _H	IEX3
External Interrupt 4	005B _H	IEX4
External Interrupt 5	0063 _H	IEX5
External Interrupt 6	006B _H	IEX6

勝特力材料 886-3-5753170
 勝特力電子 86-755-83298787
[Http://www.100y.com.tw](http://www.100y.com.tw)

Fail Save Mechanisms

As a means of graceful recovery from software or hardware upset a watchdog timer is provided in the C515. If the software fails to clear the watchdog timer at least every 65532 μ s (at 12 MHz clock rate), an internal hardware reset will be initiated. The software can be designed such that the watchdog times out if the program does not progress properly. The watchdog will also time out if the software error was due to hardware-related problems. This prevents the controller from malfunctioning for longer than 65 ms if a 12-MHz oscillator is used. **Figure 17** shows the block diagram of the watchdog timer unit.

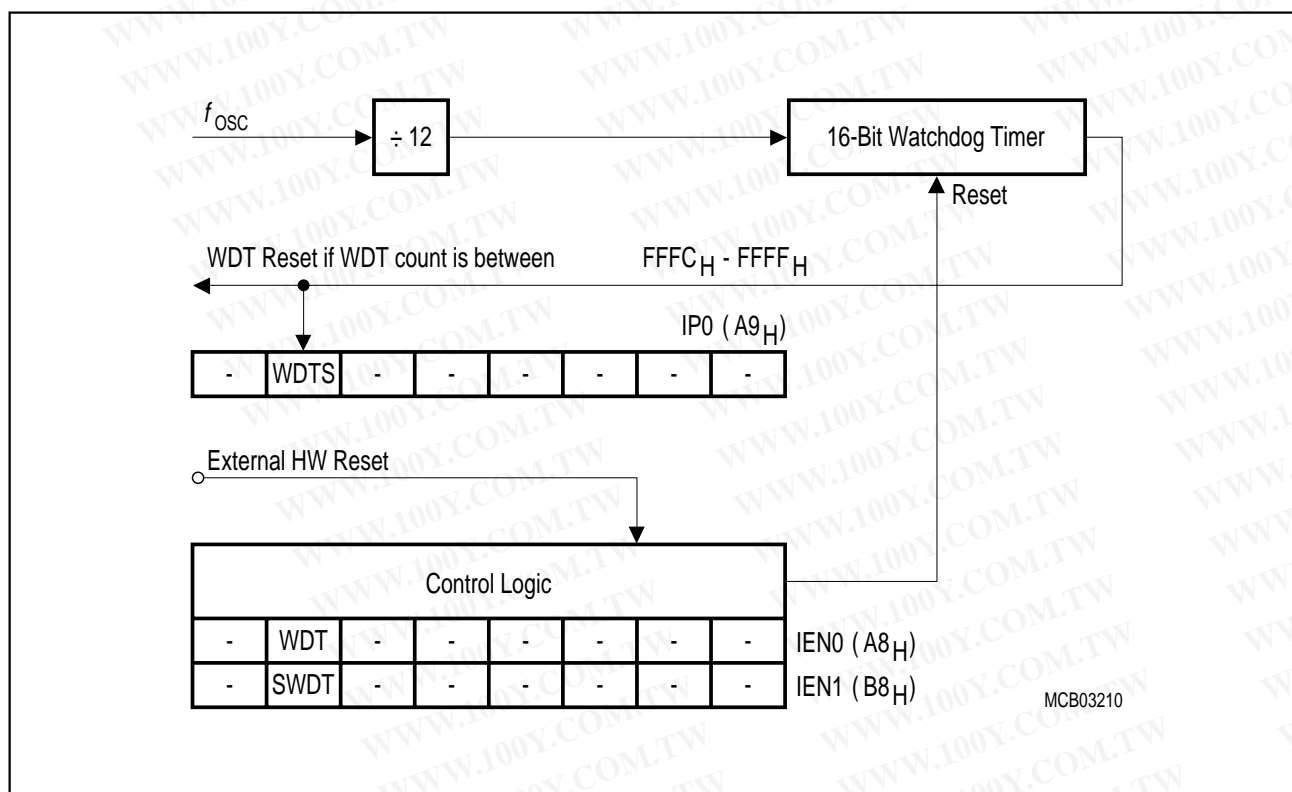

Figure 17
Block Diagram of the Watchdog Timer

The watchdog timer can be started by software (bit SWDT) but it cannot be stopped during active mode of the C515. If the software fails to clear the watchdog in time, an internally generated watchdog reset is entered at the counter state FFFC_H and lasts four instruction cycles. This internal reset differs from an external reset only to the extent that the watchdog timer is not disabled. Bit WDTS (was set by starting WDT) allows the software to examine from which source the reset was initiated. If it is set, the reset was caused by a watchdog timer overflow.

Power Saving Modes

The C515 provides two basic power saving modes, the idle mode and the power down mode. Additionally, a slow down mode is available. This power saving mode reduces the internal clock rate in normal operating mode and it can be also used for further power reduction in idle mode.

– **Idle mode**

The CPU is gated off from the oscillator. All peripherals are still provided with the clock and are able to work. Idle mode is entered by software and can be left by an interrupt or reset.

– **Power down mode**

The operation of the C515 is completely stopped and the oscillator is turned off. This mode is used to save the contents of the internal RAM with a very low standby current. Power down mode is entered by software and can be left by reset or by a short low pulse at pin P3.2/ $\overline{\text{INT0}}$.

– **Slow-down mode**

The controller keeps up the full operating functionality, but its normal clock frequency is internally divided by 8. This slows down all parts of the controller, the CPU and all peripherals, to 1/8 th of their normal operating frequency. Slowing down the frequency significantly reduces power consumption.

Table 8 gives a general overview of the entry and exit procedures of the power saving modes.

Table 8
Power Saving Modes Overview

Mode	Entering 2-Instruction Example	Leaving by	Remarks
Idle mode	ORL PCON, #01H ORL PCON, #20H	Occurrence of an interrupt from a peripheral unit	CPU clock is stopped; CPU maintains their data; peripheral units are active (if enabled) and provided with clock
		Hardware Reset	
Power Down Mode	ORL PCON, #02H ORL PCON, #40H	Hardware Reset	Oscillator is stopped; contents of on-chip RAM and SFR's are maintained;
Slow Down Mode	In normal mode : ORL PCON,#10H	ANL PCON,#0EFH or Hardware Reset	Internal clock rate is reduced to 1/8 of its nominal frequency
	With idle mode : ORL PCON,#01H ORL PCON, #30H	Occurrence of an interrupt from a peripheral unit Hardware reset	CPU clock is stopped; CPU maintains their data; peripheral units are active (if enabled) and provided with 1/8 of its nominal frequency

In the power down mode of operation, V_{CC} can be reduced to minimize power consumption. It must be ensured, however, that V_{CC} is not reduced before the power down mode is invoked, and that V_{CC} is restored to its normal operating level, before the power down mode is terminated.

Absolute Maximum Ratings

Ambient temperature under bias (T_A)	- 40 to 110 °C
Storage temperature (T_{stg})	- 65 °C to 150 °C
Voltage on V_{CC} pins with respect to ground (V_{SS})	- 0.5 V to 6.5 V
Voltage on any pin with respect to ground (V_{SS})	- 0.5 V to $V_{CC} + 0.5$ V
Input current on any pin during overload condition	- 10 mA to 10 mA
Absolute sum of all input currents during overload condition	100 mA
Power dissipation	TBD

Note: Stresses above those listed under “Absolute Maximum Ratings” may cause permanent damage of the device. This is a stress rating only and functional operation of the device at these or any other conditions above those indicated in the operational sections of this specification is not implied. Exposure to absolute maximum rating conditions for longer periods may affect device reliability. During overload conditions ($V_{IN} > V_{CC}$ or $V_{IN} < V_{SS}$) the voltage on V_{CC} pins with respect to ground (V_{SS}) must not exceed the values defined by the absolute maximum ratings.

勝特力材料 886-3-5753170
 勝特力電子 86-755-83298787
[Http://www.100y.com.tw](http://www.100y.com.tw)

DC Characteristics

$$V_{CC} = 5\text{ V} + 10\%, -15\%; V_{SS} = 0\text{ V}$$

$$T_A = 0\text{ to }70\text{ }^\circ\text{C}$$

for the SAB-C515-1RM

$$T_A = -40\text{ to }85\text{ }^\circ\text{C}$$

for the SAF-C515-1RM

$$T_A = -40\text{ to }110\text{ }^\circ\text{C}$$

for the SAH-C515-1RM

Parameter	Symbol	Limit Values		Unit	Test Condition
		min.	max.		
Input low voltages all except \overline{EA} \overline{EA} pin	V_{IL}	-0.5	$0.2 V_{CC} - 0.1$	V	-
	V_{IL1}	-0.5	$0.2 V_{CC} - 0.3$	V	-
Input high voltages all except XTAL2 and \overline{RESET} XTAL2 pin \overline{RESET} pin	V_{IH}	$0.2 V_{CC} + 0.9$	$V_{CC} + 0.5$	V	-
	V_{IH1}	$0.7 V_{CC}$	$V_{CC} + 0.5$	V	-
	V_{IH2}	$0.6 V_{CC}$	$V_{CC} + 0.5$	V	-
Output low voltages Ports 1, 2, 3, 4, 5 Port 0, ALE, \overline{PSEN}	V_{OL}	-	0.45	V	$I_{OL} = 1.6\text{ mA}^1)$
	V_{OL1}	-	0.45	V	$I_{OL} = 3.2\text{ mA}^1)$
Output high voltages Ports 1, 2, 3, 4, 5 Port 0 in external bus mode, ALE, \overline{PSEN}	V_{OH}	2.4	-	V	$I_{OH} = -80\text{ }\mu\text{A}$
		$0.9 V_{CC}$	-	V	$I_{OH} = -10\text{ }\mu\text{A}$
	V_{OH2}	2.4	-	V	$I_{OH} = -800\text{ }\mu\text{A}$
		$0.9 V_{CC}$	-	V	$I_{OH} = -80\text{ }\mu\text{A}^2)$
Logic 0 input current Ports 1, 2, 3, 4, 5	I_{IL}	-10	-70	μA	$V_{IN} = 0.45\text{ V}$
Logical 0-to-1 transition current Ports 1, 2, 3, 4, 5	I_{TL}	-65	-650	μA	$V_{IN} = 2\text{ V}$
Input leakage current Port 0, AIN0-7 (Port 6), \overline{EA}	I_{LI}	-	± 1	μA	$0.45 < V_{IN} < V_{CC}$
Input low current to \overline{RESET} for reset XTAL2 \overline{PE}	I_{LI2}	-10	-100	μA	$V_{IN} = 0.45\text{ V}$
	I_{LI3}	-	-15	μA	$V_{IN} = 0.45\text{ V}$
	I_{LI4}	-	-20	μA	$V_{IN} = 0.45\text{ V}$
Pin capacitance	C_{IO}	-	10	pF	$f_c = 1\text{ MHz},$ $T_A = 25\text{ }^\circ\text{C}$
Overload current	I_{OV}	-	± 5	mA	^{7) 8)}

Notes on next page

Power Supply Current

Parameter		Symbol	Limit Values		Unit	Test Condition
			typ. ⁹⁾	max. ¹⁰⁾		
Active mode	16 MHz	I_{CC}	13.7	18.2	mA	4)
	24 MHz	I_{CC}	19.6	25	mA	
Idle mode	16 MHz	I_{CC}	6.9	9.6	mA	5)
	24 MHz	I_{CC}	9.1	12.8	mA	
Active mode with slow-down enabled	16 MHz	I_{CC}	4.9	7.0	mA	6)
	24 MHz	I_{CC}	6.5	8.8	mA	
Power-down mode		I_{PD}	10	30	μ A	$V_{CC} = 2...5.5 V^{3)}$

- 1) Capacitive loading on ports 0 and 2 may cause spurious noise pulses to be superimposed on the V_{OL} of ALE and ports 1, 3, 4, and 5. The noise is due to external bus capacitance discharging into the port 0 and port 2 pins when these pins make 1-to-0 transitions during bus operation. In the worst case (capacitive loading > 100 pF), the noise pulse on ALE line may exceed 0.8 V. In such cases it may be desirable to qualify ALE with a schmitt-trigger, or use an address latch with a schmitt-trigger strobe input.
- 2) Capacitive loading on ports 0 and 2 may cause the V_{OH} on ALE and \overline{PSEN} to momentarily fall below the 0.9 V_{CC} specification when the address lines are stabilizing.
- 3) I_{PD} (power-down mode) is measured under following conditions:
 $\overline{EA} = \text{Port 0} = \text{Port 6} = V_{CC}$; $\overline{RESET} = V_{CC}$; XTAL1 = N.C.; $\overline{PE} = \text{XTAL2} = V_{SS}$; $V_{AGND} = V_{SS}$; $V_{AREF} = V_{CC}$; all other pins are disconnected. The typical I_{PD} current is measured at $V_{CC} = 5 V$.
- 4) I_{CC} (active mode) is measured with:
 XTAL2 driven with t_{CLCH} , $t_{CHCL} = 5 ns$, $V_{IL} = V_{SS} + 0.5 V$, $V_{IH} = V_{CC} - 0.5 V$; XTAL1 = N.C.;
 $\overline{EA} = \text{Port 0} = \text{Port 6} = V_{CC}$; $\overline{RESET} = V_{SS}$; all other pins are disconnected.
- 5) I_{CC} (idle mode) is measured with all output pins disconnected and with all peripherals disabled;
 XTAL2 driven with t_{CLCH} , $t_{CHCL} = 5 ns$, $V_{IL} = V_{SS} + 0.5 V$, $V_{IH} = V_{CC} - 0.5 V$; XTAL1 = N.C.;
 $\overline{EA} = \text{Port 0} = \text{Port 6} = V_{CC}$; $\overline{RESET} = V_{CC}$; all other pins are disconnected;
- 6) I_{CC} (active mode with slow-down mode) is measured : TBD
- 7) I_{CC} (active mode with slow-down mode) is measured : TBD
- 8) Overload conditions occur if the standard operating conditions are exceeded, i.e. the voltage on any pin exceeds the specified range (i.e. $V_{OV} > V_{CC} + 0.5 V$ or $V_{OV} < V_{SS} - 0.5 V$). The supply voltage V_{CC} and V_{SS} must remain within the specified limits. The absolute sum of input currents on all port pins may not exceed 50 mA.
- 9) Not 100% tested, guaranteed by design characterization
- 10) The typical I_{CC} values are periodically measured at $T_A = +25^\circ C$ but not 100% tested.

勝特力材料 886-3-5753170
 勝特力電子 86-755-83298787
[Http://www.100y.com.tw](http://www.100y.com.tw)

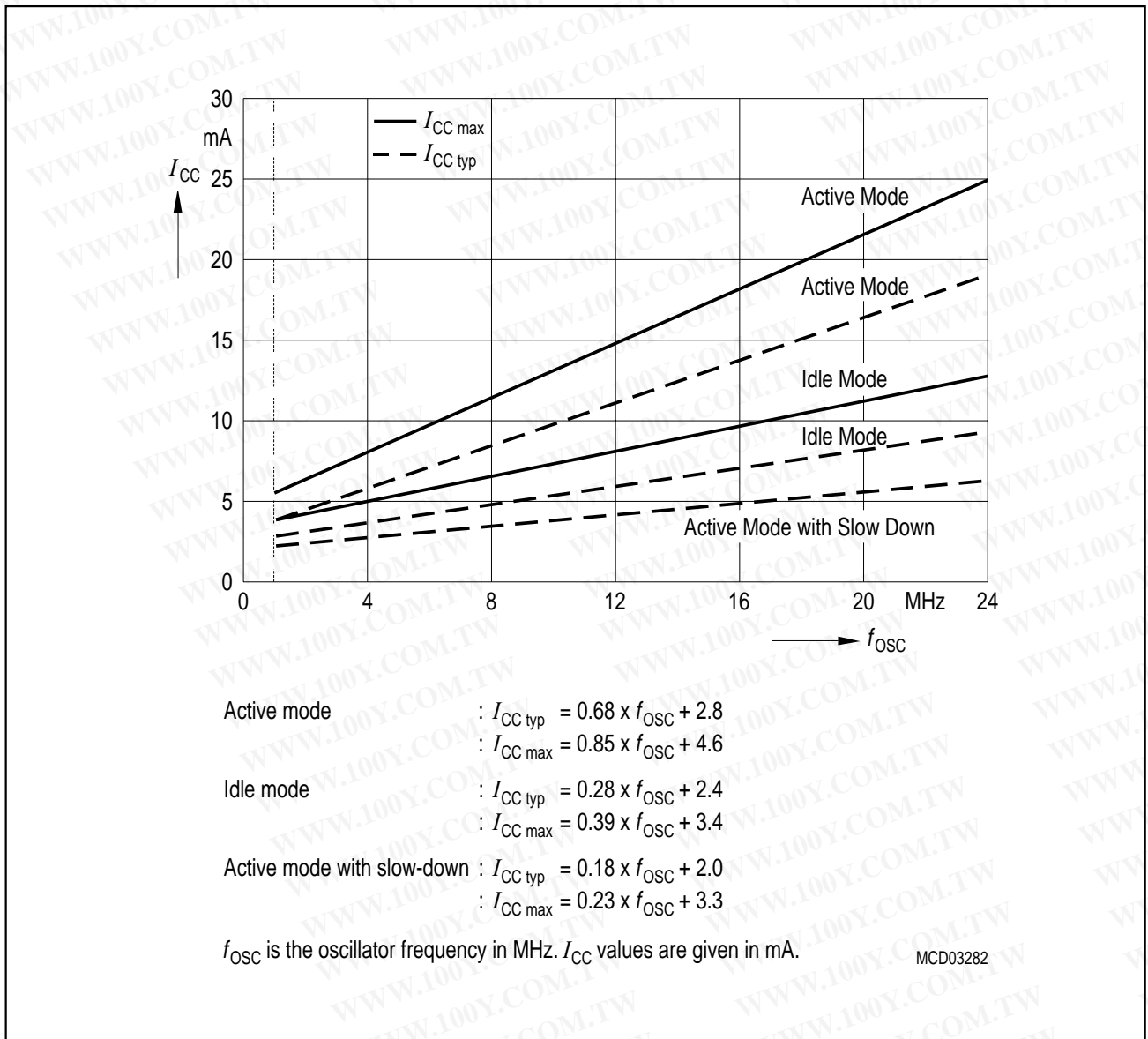

Figure 18
 ICC Diagram

勝特力材料 886-3-5753170
 勝特力電子 86-755-83298787
[Http://www.100y.com.tw](http://www.100y.com.tw)

A/D Converter Characteristics

$$V_{CC} = 5\text{ V} + 10\%, -15\%; V_{SS} = 0\text{ V}$$

$$T_A = 0\text{ to }70\text{ }^\circ\text{C}$$

for the SAB-C515-1RM

$$T_A = -40\text{ to }85\text{ }^\circ\text{C}$$

for the SAF-C515-1RM

$$T_A = -40\text{ to }110\text{ }^\circ\text{C}$$

for the SAH-C515-1RM

$$V_{CC} - 0.25\text{ V} \leq V_{AREF} \leq V_{CC} + 0.25\text{ V}; V_{SS} - 0.2\text{ V} \leq V_{AGND} \leq V_{SS} + 0.2\text{ V}; V_{IntAREF} - V_{IntAGND} \geq 1\text{ V};$$

Parameter	Symbol	Limit Values		Unit	Test Condition
		min.	max.		
Analog input voltage	V_{AIN}	$V_{AGND} - 0.2$	$V_{AREF} + 0.2$	V	1)
A/D converter input clock	t_{IN}	—	$2 \times t_{CLCL}$	ns	
Sample time	t_S	—	$16 \times t_{IN}$	ns	2)
Conversion cycle time	t_{ADCC}	—	$80 \times t_{IN}$	ns	3)
Total unadjusted error	T_{UE}	—	± 1	LSB	$V_{IntAREF} = V_{AREF} = V_{CC}$ $V_{IntAGND} = V_{AGND} = V_{SS}$ 4)
Internal resistance of reference voltage source	R_{AREF}	—	$8 \times t_{IN} / 500 - 1$	k Ω	t_{IN} in [ns] 5) 6)
Internal resistance of analog source	R_{ASRC}	—	$t_S / 500 - 1$	k Ω	t_S in [ns] 2) 6)
ADC input capacitance	C_{AIN}	—	45	pF	6)

Notes:

- 1) V_{AIN} may exceed V_{AGND} or V_{AREF} up to the absolute maximum ratings. However, the conversion result in these cases will be 00_H or FF_H, respectively.
- 2) During the sample time the input capacitance C_{AIN} can be charged/discharged by the external source. The internal resistance of the analog source must allow the capacitance to reach their final voltage level within t_S . After the end of the sample time t_S , changes of the analog input voltage have no effect on the conversion result.
- 3) This parameter includes the sample time t_S and the conversion time t_C . The values for the conversion clock t_{ADC} is always $8 \times t_{IN}$.
- 4) T_{UE} is tested at $V_{AREF} = 5.0\text{ V}$, $V_{AGND} = 0\text{ V}$, $V_{CC} = 4.9\text{ V}$. It is guaranteed by design characterization for all other voltages within the defined voltage range.
If an overload condition occurs on maximum 2 not selected analog input pins and the absolute sum of input overload currents on all analog input pins does not exceed 10 mA, an additional conversion error of 1/2 LSB is permissible.
- 5) During the conversion the ADC's capacitance must be repeatedly charged or discharged. The internal resistance of the reference source must allow the capacitance to reach their final voltage level within the indicated time. The maximum internal resistance results from the programmed conversion timing.
- 6) Not 100% tested, but guaranteed by design characterization.

AC Characteristics (16 MHz)

$V_{CC} = 5\text{ V} + 10\%, -15\%$; $V_{SS} = 0\text{ V}$

$T_A = 0\text{ to }70\text{ }^\circ\text{C}$

for the SAB-C515-1RM

$T_A = -40\text{ to }85\text{ }^\circ\text{C}$

for the SAF-C515-1RM

$T_A = -40\text{ to }110\text{ }^\circ\text{C}$

for the SAH-C515-1RM

(C_L for port 0, ALE and $\overline{\text{PSEN}}$ outputs = 100 pF; C_L for all other outputs = 80 pF)

Program Memory Characteristics

Parameter	Symbol	Limit Values				Unit
		16 MHz Clock		Variable Clock $1/t_{\text{CLCL}} = 1\text{ MHz to }16\text{ MHz}$		
		min.	max.	min.	max.	
ALE pulse width	t_{LHLL}	85	–	$2t_{\text{CLCL}} - 40$	–	ns
Address setup to ALE	t_{AVLL}	33	–	$t_{\text{CLCL}} - 30$	–	ns
Address hold after ALE	t_{LLAX}	28	–	$t_{\text{CLCL}} - 35$	–	ns
ALE low to valid instr in	t_{LLIV}	–	150	–	$4t_{\text{CLCL}} - 100$	ns
ALE to $\overline{\text{PSEN}}$	t_{LLPL}	38	–	$t_{\text{CLCL}} - 25$	–	ns
$\overline{\text{PSEN}}$ pulse width	t_{PLPH}	153	–	$3t_{\text{CLCL}} - 35$	–	ns
$\overline{\text{PSEN}}$ to valid instr in	t_{PLIV}	–	88	–	$3t_{\text{CLCL}} - 100$	ns
Input instruction hold after $\overline{\text{PSEN}}$	t_{PXIX}	0	–	0	–	ns
Input instruction float after $\overline{\text{PSEN}}$	$t_{\text{PXIZ}}^*)$	–	43	–	$t_{\text{CLCL}} - 20$	ns
Address valid after $\overline{\text{PSEN}}$	$t_{\text{PXAV}}^*)$	55	–	$t_{\text{CLCL}} - 8$	–	ns
Address to valid instr in	t_{AVIV}	–	198	–	$5t_{\text{CLCL}} - 115$	ns
Address float to $\overline{\text{PSEN}}$	t_{AZPL}	0	–	0	–	ns

^{*)} Interfacing the C515 to devices with float times up to 75 ns is permissible. This limited bus contention will not cause any damage to port 0 drivers.

CLKOUT Characteristics

Parameter	Symbol	Limit Values				Unit
		16 MHz Clock		Variable Clock $1/t_{\text{CLCL}} = 1\text{ MHz to }16\text{ MHz}$		
		min.	max.	min.	max.	
ALE to CLKOUT	t_{LLSH}	398	–	$7 t_{\text{CLCL}} - 40$	–	ns
CLKOUT high time	t_{SHSL}	85	–	$2 t_{\text{CLCL}} - 40$	–	ns
CLKOUT low time	t_{SLSH}	585	–	$10 t_{\text{CLCL}} - 40$	–	ns
CLKOUT low to ALE high	t_{SLLH}	23	103	$t_{\text{CLCL}} - 40$	$t_{\text{CLCL}} + 40$	ns

AC Characteristics (16 MHz) (cont'd)

External Data Memory Characteristics

Parameter	Symbol	Limit Values				Unit
		16 MHz Clock		Variable Clock $1/t_{CLCL} = 1 \text{ MHz to } 16 \text{ MHz}$		
		min.	max.	min.	max.	
\overline{RD} pulse width	t_{RLRH}	275	–	$6t_{CLCL} - 100$	–	ns
\overline{WR} pulse width	t_{WLWH}	275	–	$6t_{CLCL} - 100$	–	ns
Address hold after ALE	t_{LLAX2}	90	–	$2t_{CLCL} - 35$	–	ns
\overline{RD} to valid data in	t_{RLDV}	–	148	–	$5t_{CLCL} - 165$	ns
Data hold after \overline{RD}	t_{RHDX}	0	–	0	–	ns
Data float after \overline{RD}	t_{RHDZ}	–	55	–	$2t_{CLCL} - 70$	ns
ALE to valid data in	t_{LLDV}	–	350	–	$8t_{CLCL} - 150$	ns
Address to valid data in	t_{AVDV}	–	398	–	$9t_{CLCL} - 165$	ns
ALE to \overline{WR} or \overline{RD}	t_{LLWL}	138	238	$3t_{CLCL} - 50$	$3t_{CLCL} + 50$	ns
Address valid to \overline{WR} or \overline{RD}	t_{AVWL}	120	–	$4t_{CLCL} - 130$	–	ns
\overline{WR} or \overline{RD} high to ALE high	t_{WHLH}	23	103	$t_{CLCL} - 40$	$t_{CLCL} + 40$	ns
Data valid to \overline{WR} transition	t_{QVWX}	13	–	$t_{CLCL} - 50$	–	ns
Data setup before \overline{WR}	t_{QVWH}	288	–	$7t_{CLCL} - 150$	–	ns
Data hold after \overline{WR}	t_{WHQX}	13	–	$t_{CLCL} - 50$	–	ns
Address float after \overline{RD}	t_{RLAZ}	–	0	–	0	ns

External Clock Drive Characteristics

Parameter	Symbol	Limit Values		Unit
		Variable Clock Freq. = 1 MHz to 16 MHz		
		min.	max.	
Oscillator period	t_{CLCL}	62.5	1000	ns
High time	t_{CHCX}	15	$t_{CLCL} - t_{CLCX}$	ns
Low time	t_{CLCX}	15	$t_{CLCL} - t_{CHCX}$	ns
Rise time	t_{CLCH}	–	15	ns
Fall time	t_{CHCL}	–	15	ns

AC Characteristics (24 MHz)

$V_{CC} = 5\text{ V} + 10\%, -15\%$; $V_{SS} = 0\text{ V}$

$T_A = 0\text{ to }70\text{ }^\circ\text{C}$

for the SAB-C515-1RM

$T_A = -40\text{ to }85\text{ }^\circ\text{C}$

for the SAF-C515-1RM

$T_A = -40\text{ to }110\text{ }^\circ\text{C}$

for the SAH-C515-1RM

(C_L for port 0, ALE and $\overline{\text{PSEN}}$ outputs = 100 pF; C_L for all other outputs = 80 pF)

Program Memory Characteristics

Parameter	Symbol	Limit Values				Unit
		24 MHz Clock		Variable Clock $1/t_{\text{CLCL}} = 1\text{ MHz to }24\text{ MHz}$		
		min.	max.	min.	max.	
ALE pulse width	t_{LHLL}	43	–	$2t_{\text{CLCL}} - 40$	–	ns
Address setup to ALE	t_{AVLL}	17	–	$t_{\text{CLCL}} - 25$	–	ns
Address hold after ALE	t_{LLAX}	17	–	$t_{\text{CLCL}} - 25$	–	ns
ALE low to valid instr in	t_{LLIV}	–	80	–	$4t_{\text{CLCL}} - 87$	ns
ALE to $\overline{\text{PSEN}}$	t_{LLPL}	22	–	$t_{\text{CLCL}} - 20$	–	ns
$\overline{\text{PSEN}}$ pulse width	t_{PLPH}	95	–	$3t_{\text{CLCL}} - 30$	–	ns
$\overline{\text{PSEN}}$ to valid instr in	t_{PLIV}	–	60	–	$3t_{\text{CLCL}} - 65$	ns
Input instruction hold after $\overline{\text{PSEN}}$	t_{PXIX}	0	–	0	–	ns
Input instruction float after $\overline{\text{PSEN}}$	$t_{\text{PXIZ}}^*)$	–	32	–	$t_{\text{CLCL}} - 10$	ns
Address valid after $\overline{\text{PSEN}}$	$t_{\text{PXAV}}^*)$	37	–	$t_{\text{CLCL}} - 5$	–	ns
Address to valid instr in	t_{AVIV}	–	148	–	$5t_{\text{CLCL}} - 60$	ns
Address float to $\overline{\text{PSEN}}$	t_{AZPL}	0	–	0	–	ns

^{*)} Interfacing the C515 to devices with float times up to 37 ns is permissible. This limited bus contention will not cause any damage to port 0 drivers.

CLKOUT Characteristics

Parameter	Symbol	Limit Values				Unit
		24 MHz Clock		Variable Clock $1/t_{\text{CLCL}} = 1\text{ MHz to }24\text{ MHz}$		
		min.	max.	min.	max.	
ALE to CLKOUT	t_{LLSH}	252	–	$7 t_{\text{CLCL}} - 40$	–	ns
CLKOUT high time	t_{SHSL}	43	–	$2 t_{\text{CLCL}} - 40$	–	ns
CLKOUT low time	t_{SLSH}	377	–	$10 t_{\text{CLCL}} - 40$	–	ns
CLKOUT low to ALE high	t_{SLLH}	2	82	$t_{\text{CLCL}} - 40$	$t_{\text{CLCL}} + 40$	ns

AC Characteristics (24 MHz) (cont'd)

External Data Memory Characteristics

Parameter	Symbol	Limit Values				Unit
		24 MHz Clock		Variable Clock $1/t_{CLCL} = 1 \text{ MHz to } 24 \text{ MHz}$		
		min.	max.	min.	max.	
\overline{RD} pulse width	t_{RLRH}	180	–	$6t_{CLCL} - 70$	–	ns
\overline{WR} pulse width	t_{WLWH}	180	–	$6t_{CLCL} - 70$	–	ns
Address hold after ALE	t_{LLAX2}	15	–	$t_{CLCL} - 27$	–	ns
\overline{RD} to valid data in	t_{RLDV}	–	118	–	$5t_{CLCL} - 90$	ns
Data hold after \overline{RD}	t_{RHDX}	0	–	0	–	ns
Data float after \overline{RD}	t_{RHDZ}	–	63	–	$2t_{CLCL} - 20$	ns
ALE to valid data in	t_{LLDV}	–	200	–	$8t_{CLCL} - 133$	ns
Address to valid data in	t_{AVDV}	–	220	–	$9t_{CLCL} - 155$	ns
ALE to \overline{WR} or \overline{RD}	t_{LLWL}	75	175	$3t_{CLCL} - 50$	$3t_{CLCL} + 50$	ns
Address valid to \overline{WR} or \overline{RD}	t_{AVWL}	67	–	$4t_{CLCL} - 97$	–	ns
\overline{WR} or \overline{RD} high to ALE high	t_{WHLH}	17	67	$t_{CLCL} - 25$	$t_{CLCL} + 25$	ns
Data valid to \overline{WR} transition	t_{QVWX}	5	–	$t_{CLCL} - 37$	–	ns
Data setup before \overline{WR}	t_{QVWH}	170	–	$7t_{CLCL} - 122$	–	ns
Data hold after \overline{WR}	t_{WHQX}	15	–	$t_{CLCL} - 27$	–	ns
Address float after \overline{RD}	t_{RLAZ}	–	0	–	0	ns

External Clock Drive Characteristics

Parameter	Symbol	Limit Values		Unit
		Variable Clock Freq. = 1 MHz to 24 MHz		
		min.	max.	
Oscillator period	t_{CLCL}	41.7	1000	ns
High time	t_{CHCX}	12	$t_{CLCL} - t_{CLCX}$	ns
Low time	t_{CLCX}	12	$t_{CLCL} - t_{CHCX}$	ns
Rise time	t_{CLCH}	–	12	ns
Fall time	t_{CHCL}	–	12	ns

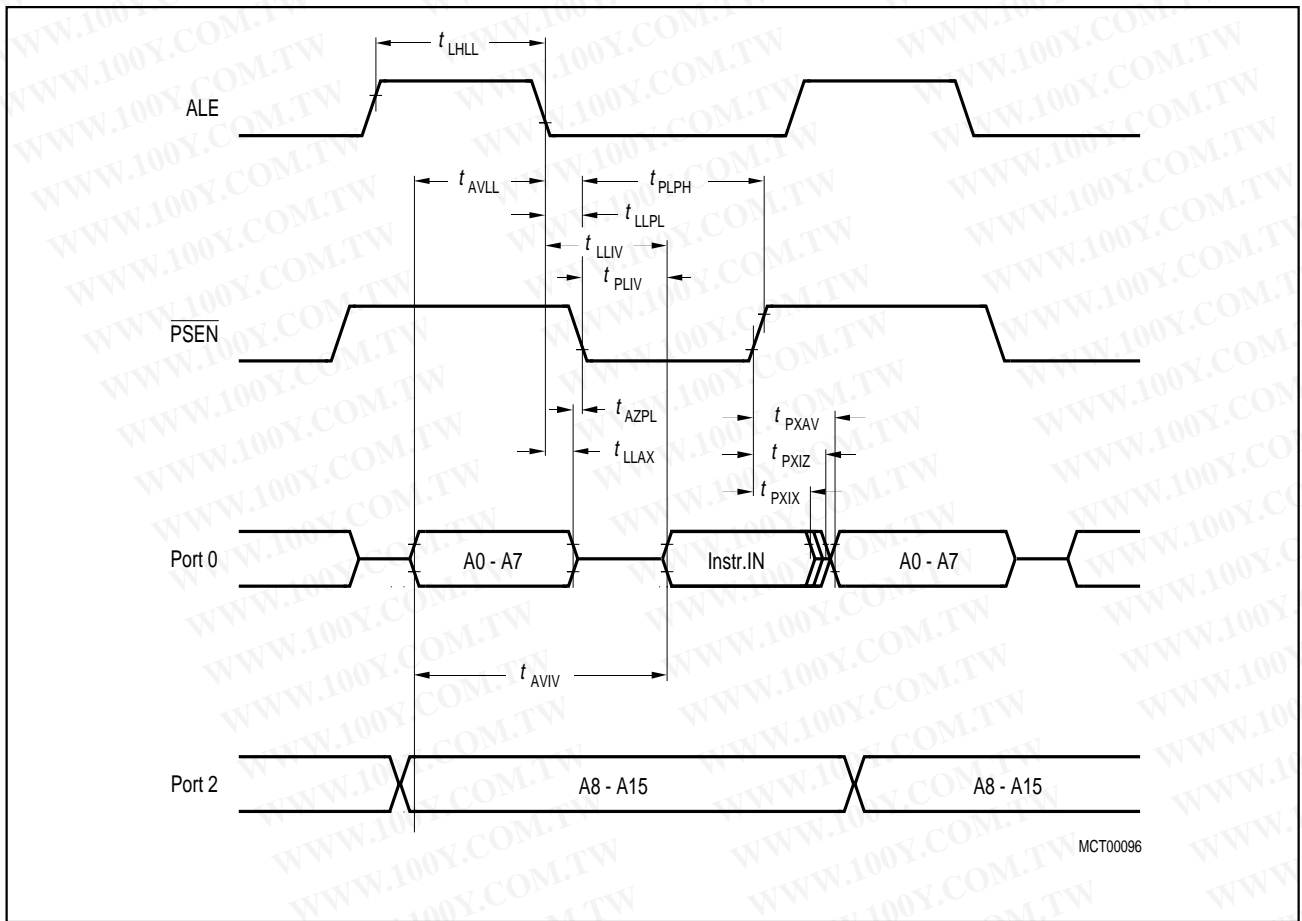

Figure 19
Program Memory Read Cycle

勝特力材料 886-3-5753170
 勝特力電子 86-755-83298787
[Http://www.100y.com.tw](http://www.100y.com.tw)

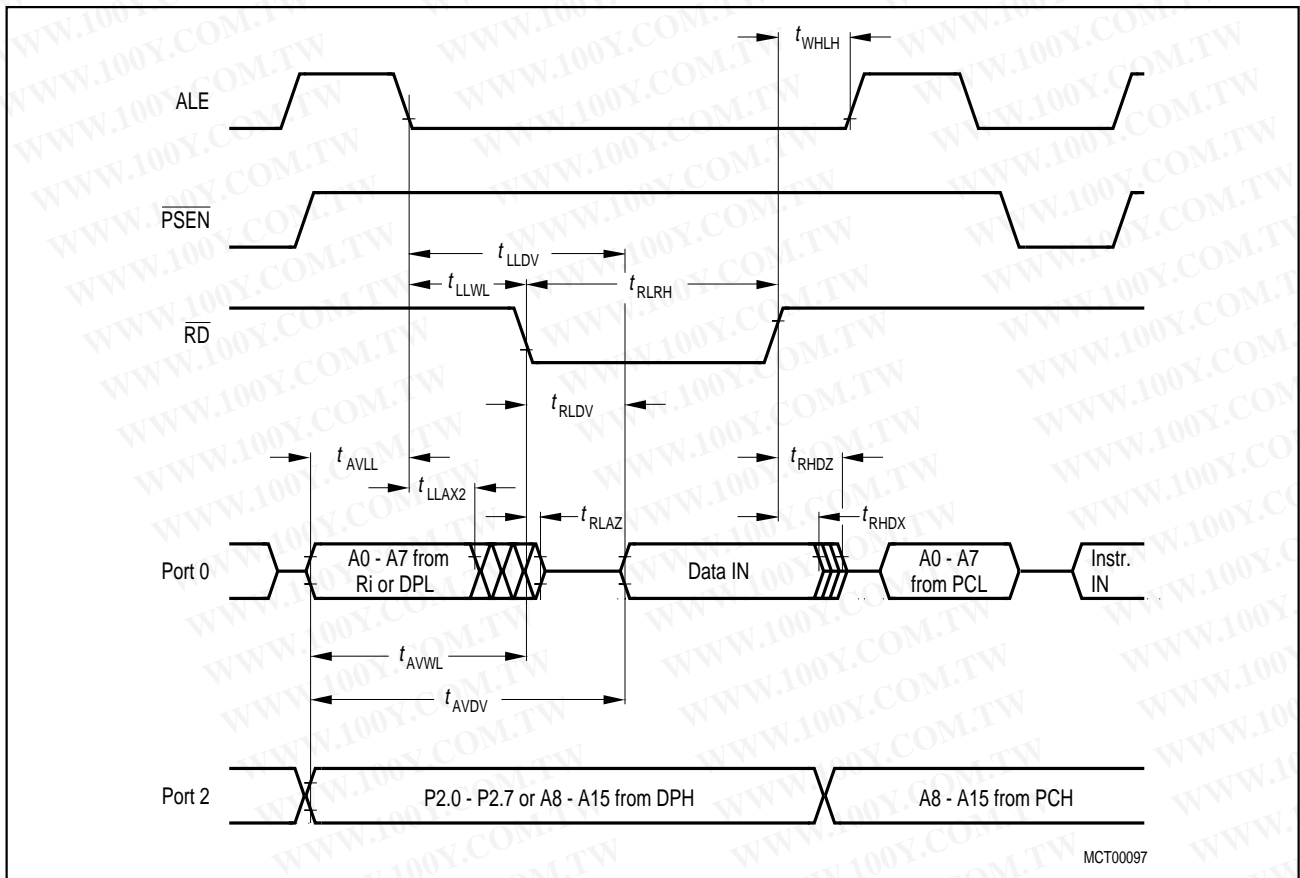

Figure 20
Data Memory Read Cycle

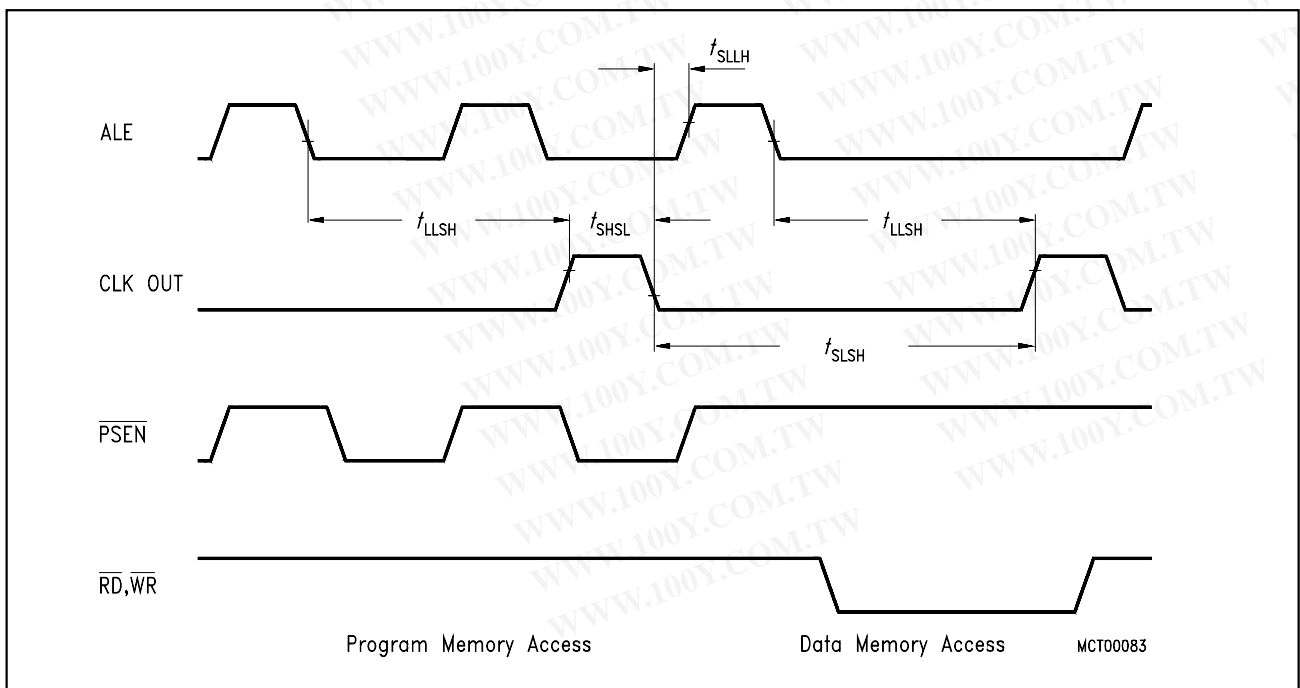

Figure 21
CLKOUT Timing

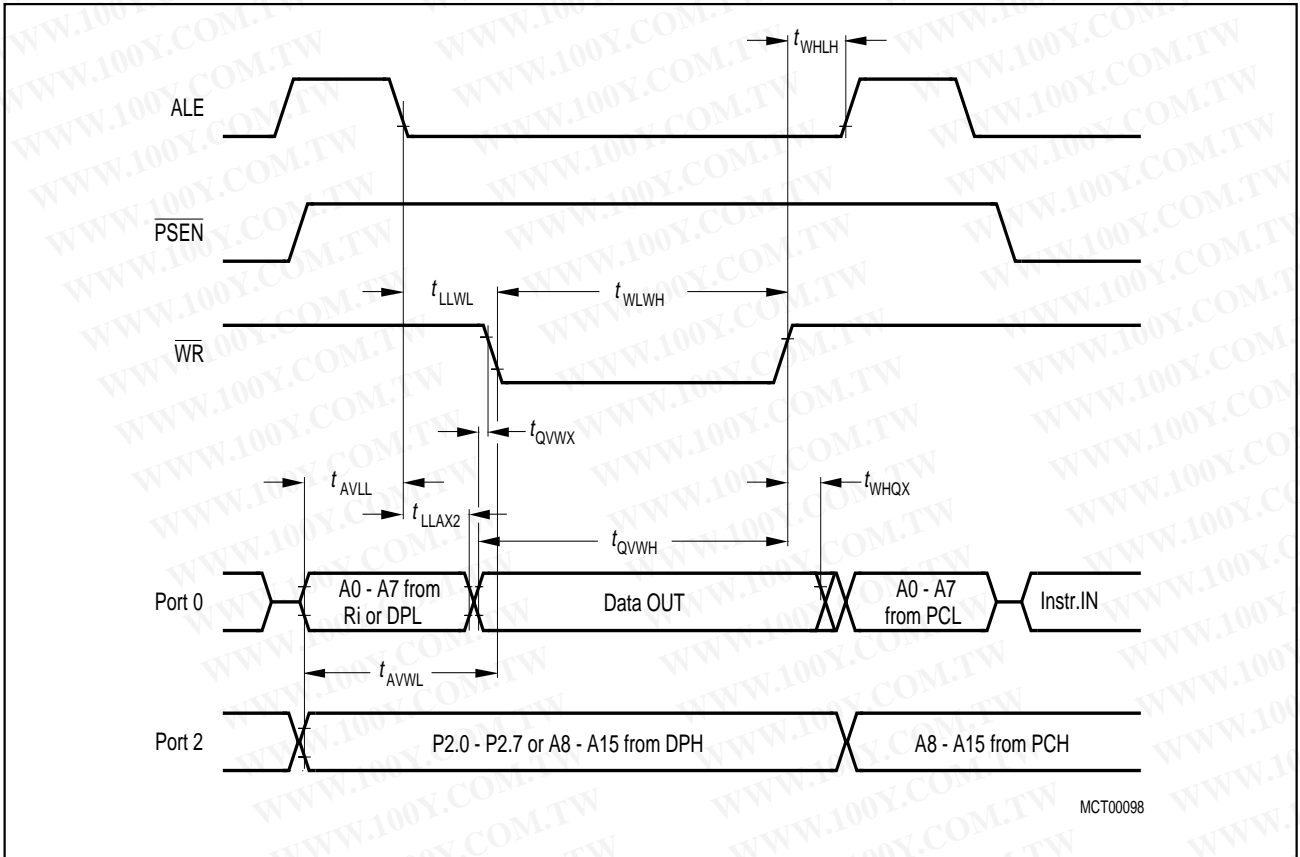

Figure 22
Data Memory Write Cycle

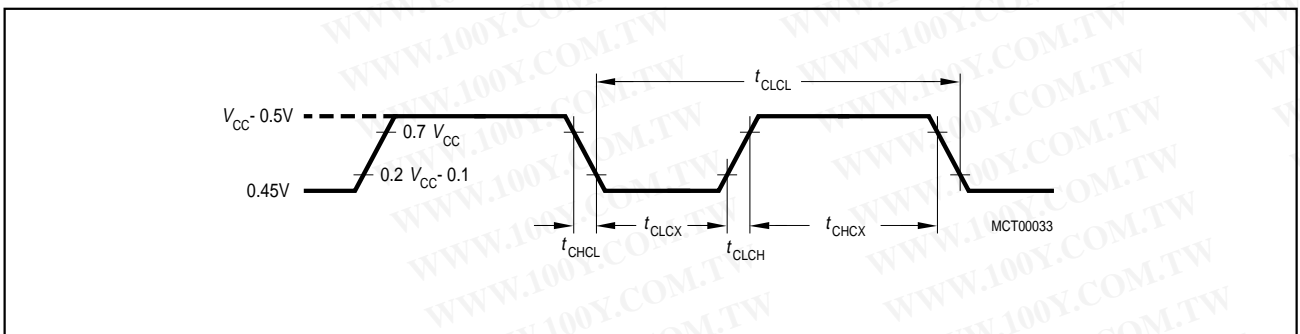

Figure 23
External Clock Drive at XTAL2

勝特力材料 886-3-5753170
 勝特力電子 86-755-83298787
[Http://www.100y.com.tw](http://www.100y.com.tw)

ROM Verification Characteristics for the C515-1RM

ROM Verification Mode 1

Parameter	Symbol	Limit Values		Unit
		min.	max.	
Address to valid data	t_{AVQV}	—	$10 t_{CLCL}$	ns

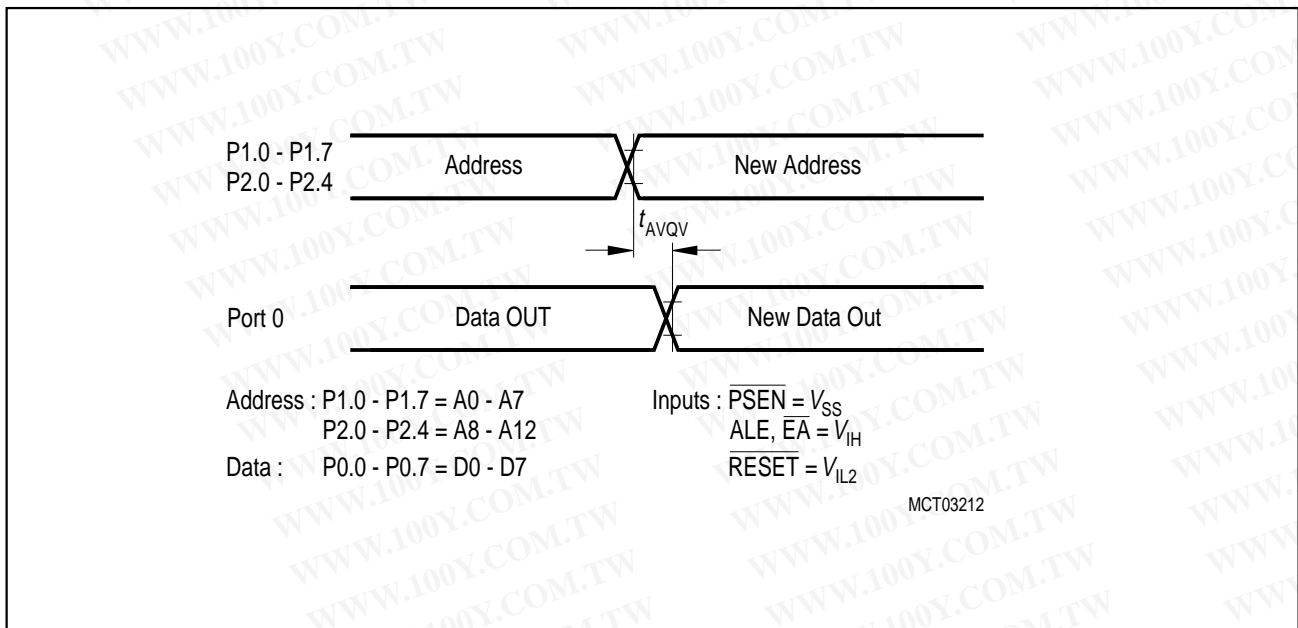

Figure 24
ROM Verification Mode 1

勝特力材料 886-3-5753170
 勝特力电子(上海) 86-21-54151736
 勝特力电子(深圳) 86-755-83298787
[Http://www.100y.com.tw](http://www.100y.com.tw)

ROM Verification Mode 2

Parameter	Symbol	Limit Values			Unit
		min.	typ	max.	
ALE pulse width	t_{AWD}	—	$2 t_{CLCL}$	—	ns
ALE period	t_{ACY}	—	$12 t_{CLCL}$	—	ns
Data valid after ALE	t_{DVA}	—	—	$4 t_{CLCL}$	ns
Data stable after ALE	t_{DSA}	$8 t_{CLCL}$	—	—	ns
P3.5 setup to ALE low	t_{AS}	—	t_{CLCL}	—	ns
Oscillator frequency	$1/t_{CLCL}$	1	—	24	MHz

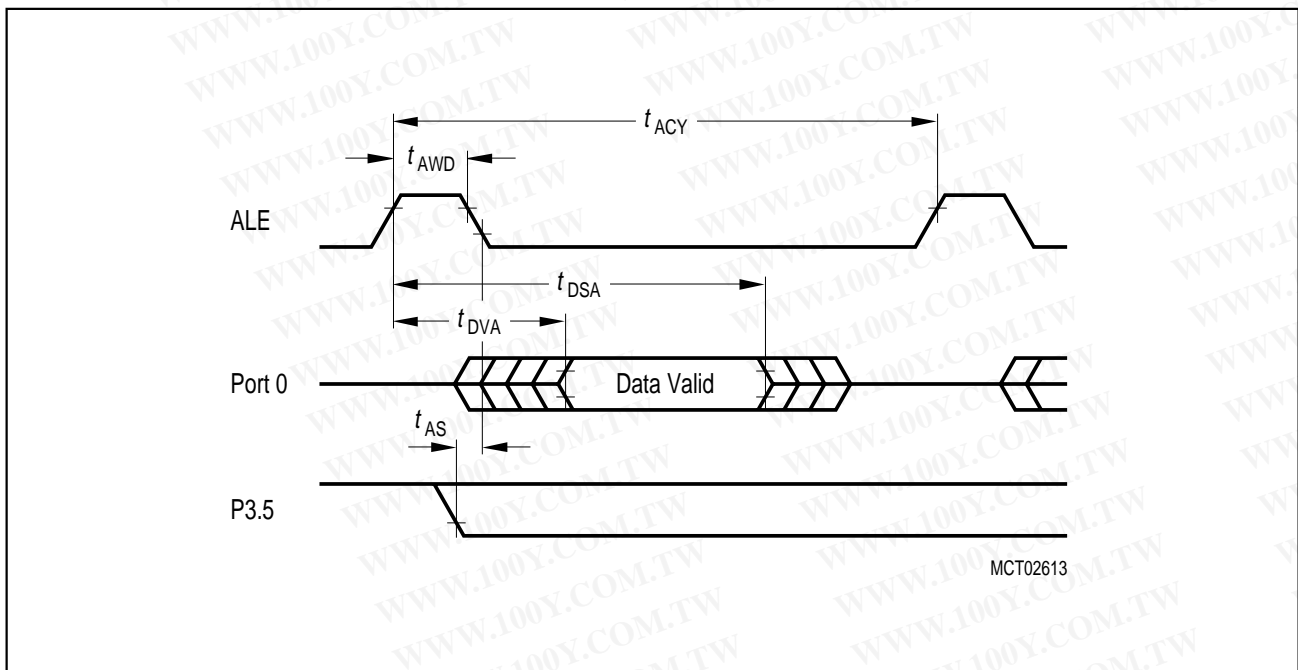

Figure 25
ROM Verification Mode 2

勝特力材料 886-3-5753170
 勝特力電子 86-755-83298787
[Http://www.100y.com.tw](http://www.100y.com.tw)

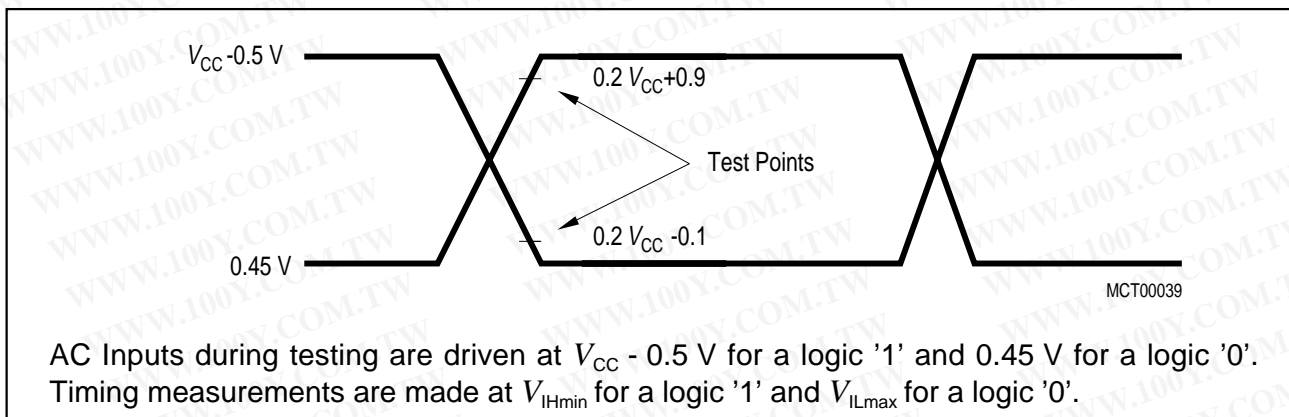

Figure 26
AC Testing: Input, Output Waveforms

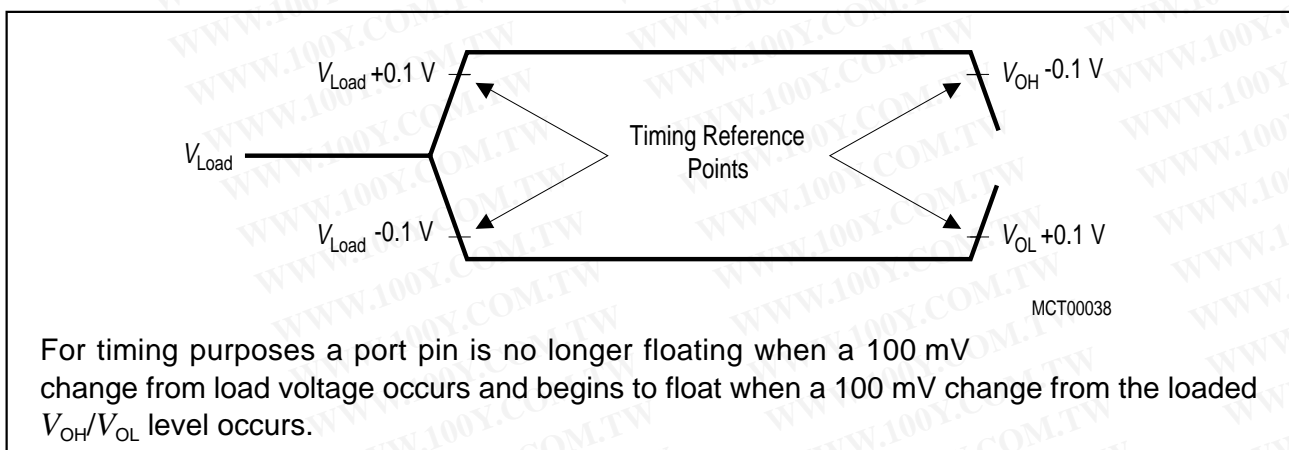

Figure 27
AC Testing : Float Waveforms

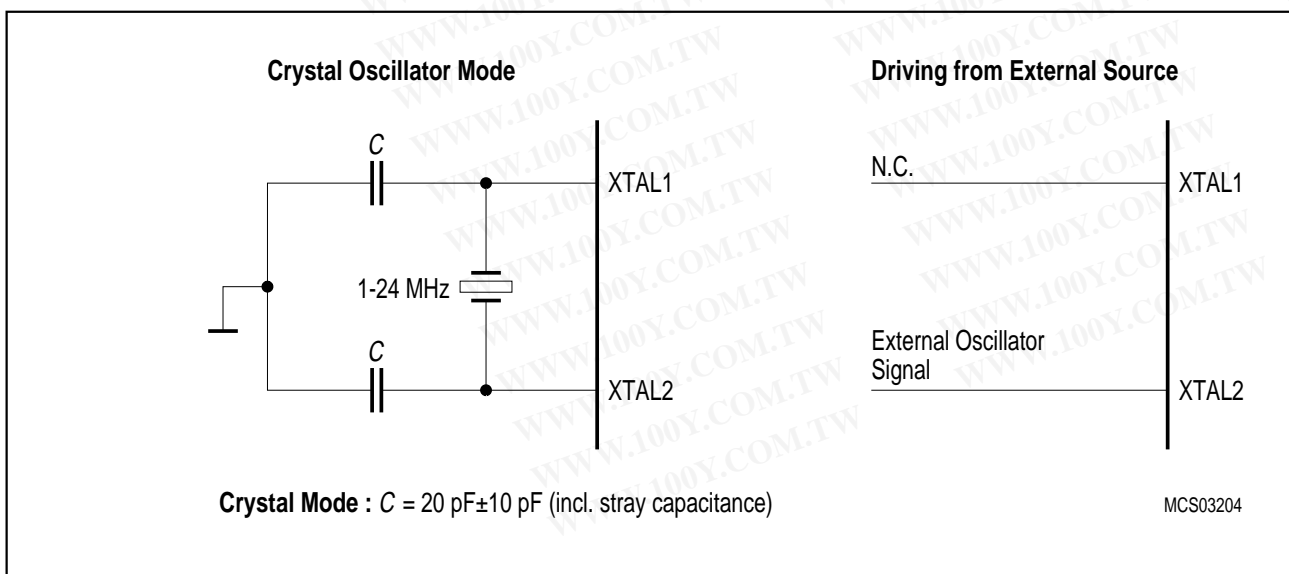

Figure 28
Recommended Oscillator Circuits for Crystal Oscillator

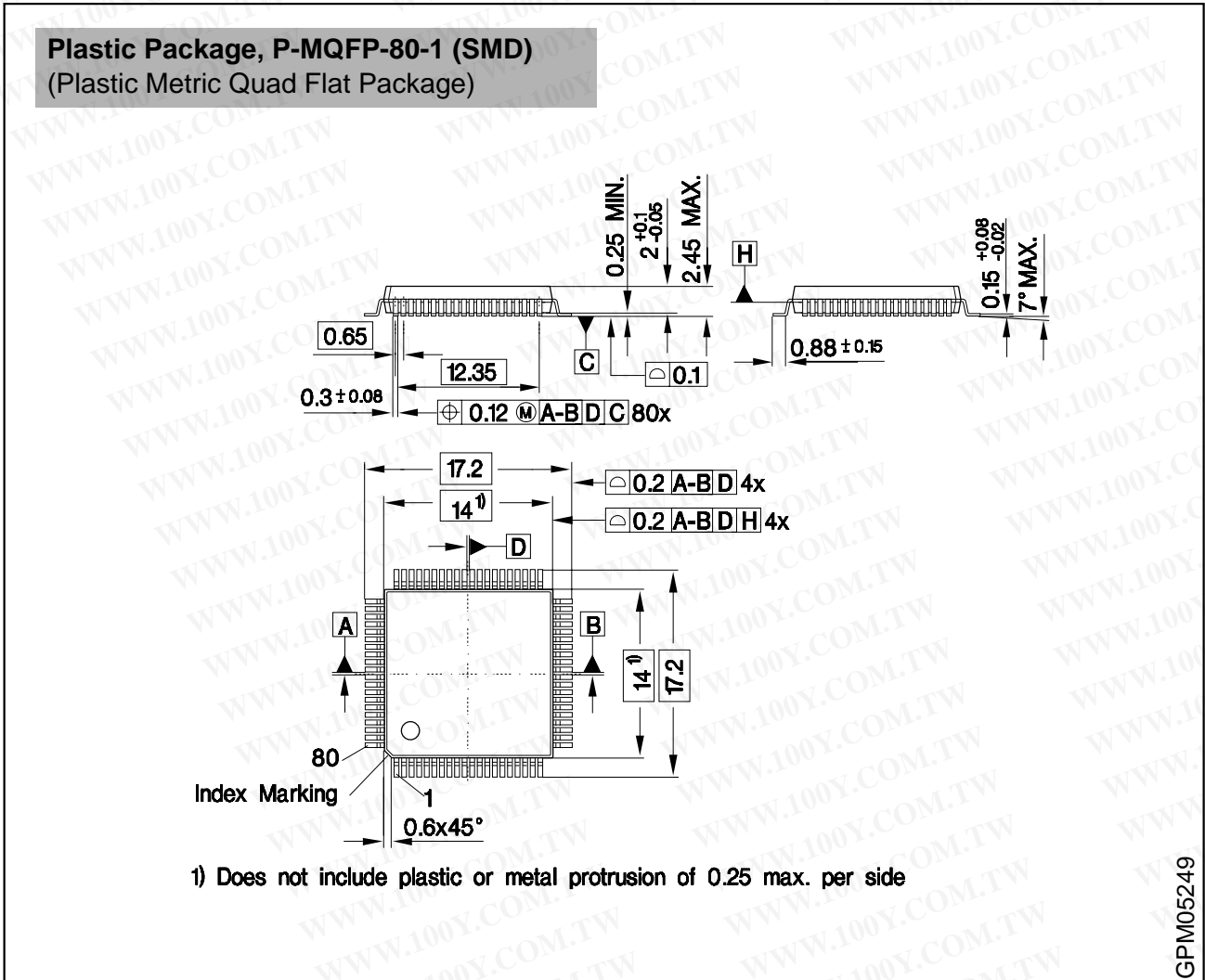

Figure 29
P-MQFP-80-1 Package Outlines

勝特力材料 886-3-5753170
 勝特力电子(上海) 86-21-54151736
 勝特力电子(深圳) 86-755-83298787
[Http://www.100y.com.tw](http://www.100y.com.tw)

Sorts of Packing

Package outlines for tubes, trays etc. are contained in our Data Book "Package Information"

SMD = Surface Mounted Device

Dimensions in mm