



3-Phase Stepping Motor Drive IC for Universal Controller

PMM3501 Micro step

勝特力材料 886-3-5753170
 勝特力电子(上海) 86-21-54151736
 勝特力电子(深圳) 86-755-83298787
[Http://www.100y.com.tw](http://www.100y.com.tw)

Outline

The PMM3501 IC for stepping motor drive is a power hybrid IC (HIC) that consists of an energization mode generation circuit and a switching device to drive 3-phase stepping motors in a single package.

It has been developed to facilitate the use of 3-phase stepping motors more easily so that you can easily configure a micro step drive device only with this HIC and a few peripheral parts.

Features

- Micro step sine wave drive driver
- Built-in current detection resistor
- Adopting MOSFET as the power drive device to reduce heat generation
- All-in-one package reducing the number of parts of the peripheral circuit
- 5 energization modes available with an external bit signal

Maximum ratings (T_C=25°C)

Item	Symbol	Condition	Rating	Unit
Source voltage-1	V _{CC1max}	V _{CC2} =0V	37	V
Source voltage-2	V _{CC2max}	Without signal	7	V
Input voltage	V _{INmax}	Logic input terminal	7	V
Phase current	I _{Omax}	V _{CC2} =5V, Clock 100Hz	6	A
Board temperature during operation	T _{Cmax}	No condensation at low temperature	0~+105	°C
Joint temperature	T _{Jmax}	—	+150	°C
Conservation temperature	T _{stg}	—	-40~+125	°C

Recommended operating conditions (T_a=15°C)

Item	Symbol	Condition	Rating	Unit
Source voltage-1	V _{CC1}	With signal	16~30	V
Source voltage-1	V _{CC2}	Without signal	5.0±5%	V
Input voltage	V _{IH}	—	0~V _{CC2}	V
Phase current-1	I _{O1}	Without heat sink	1.7	A
Phase current-2	I _{O2}	T _C =105°C, Clock 100Hz	4.4	A
Clock frequency	Clock	Pin 11 input frequency (pulse duty: 50%)	DC~50	kHz
Phase driver withstand voltage	V _{BSS}	I _b =10mA(T _C =25°C)	60	V

External Figures (unit: mm)

Pin connection

Pin No.	Name
1.	V _{CC1B}
2.	V _{CC1C}
3.	-
4.	UO
5.	WO
6.	VO
7.	V _Z
8.	V _{ref}
9.	GND2
10.	V _{ref}
11.	Clock
12.	Mode A
13.	Mode B
14.	Hold
15.	CW/CCW
16.	Enable
17.	Reset
18.	Mode C
19.	GND1
20.	MOI
21.	V _{CC2}
22.	-
23.	UI
24.	VI
25.	WI
26.	-
27.	PGNDA
28.	PGNDB

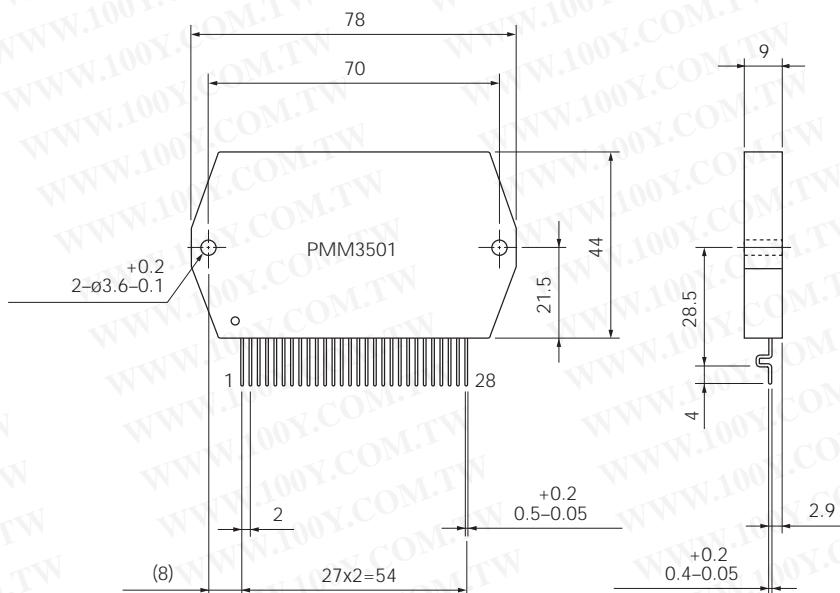

Electrical characteristics (T_C=25°C, V_{CC1}=24V, V_{CC2}=5V)

Item	Symbol	Condition	Rating			Unit
			Min	Standard	Max	
V _{CC2} source current	I _{CCO}	Enable="L"	-	6.1	12	mA
Effective output current	I _{oe}	Each phase R/L=2Ω/6mH 2W2-3phase energization	0.92	1.03	1.14	A _{rms}
FET diode forward voltage	V _{df}	I _f =1A(RL=23Ω)	-	1.0	1.6	V
Output saturation voltage	V _{sat}	RL=23Ω	-	0.30	0.40	V
Output leak current	I _{oL}	RL=23Ω	-	-	0.1	mA
"H" level input voltage	V _{IH}	Pins 11 to 18	4.0	-	-	V
"L" level input voltage	V _{IL}	Pins 11 to 18	-	-	1.0	V
Input current	I _{IL}	Pins 11 to 18 = GND level Pull-up resistance:20kΩ	115	250	550	μA
V _{ref} input voltage	V _{IH}	Pin 10	0	-	V _{CC2} /2	V
V _{ref} input current	I _f	Pin 10 = 2.5 V Internal resistance:4kΩ	440	625	810	μA
"H" level MOI output voltage	V _{OH}	Pins 20 - 19 = 820kΩ	2.5	-	-	V
"L" level MOI output voltage	V _{OL}	Pins 21 - 20 = 1.6kΩ	-	-	0.4	V
PWM frequency	F _c	-	23	31	39	kHz

Function of each terminal

Function of each terminal	function	Input condition for operation
V _{ref}	Motor current setting input	-
Clock	Pulse input for motor drive	Mode C = "H": Rising edge operation Mode C = "L": Rising edge and falling edge operation
Hold	Pause input	Hold = "L" level
CW/CCW	Motor rotational direction setting input	"H" level = CW rotation "L" level = CCW rotation
Enable	Power off input	Enable = "L" level
Reset	System reset	Reset = "L" level
MOI	Rotation monitor output	"H" level output once for each phase current period

- The MOI output differs from the phase origin monitor output.

Energization mode table

Input			condition Energization mode	1 step angle (degree)	Basic step division
Mode A	Mode B	Mode C			
L	L	H	2EX	1.2	1
L	H	H	2-3EX	0.6	2
H	L	H	W2-3EX	0.3	4
H	H	H	2W2-3EX	0.15	8
H	H	L	4W2-3EX	0.075	16

- When Mode C = "L," 1 step operation is performed for each rising edge and falling edge of the Clock pulse.
 If the duty ratio of the drive pulse moves out of the adjustment significantly by 50%, operation becomes unstable.

Example of Application Circuit

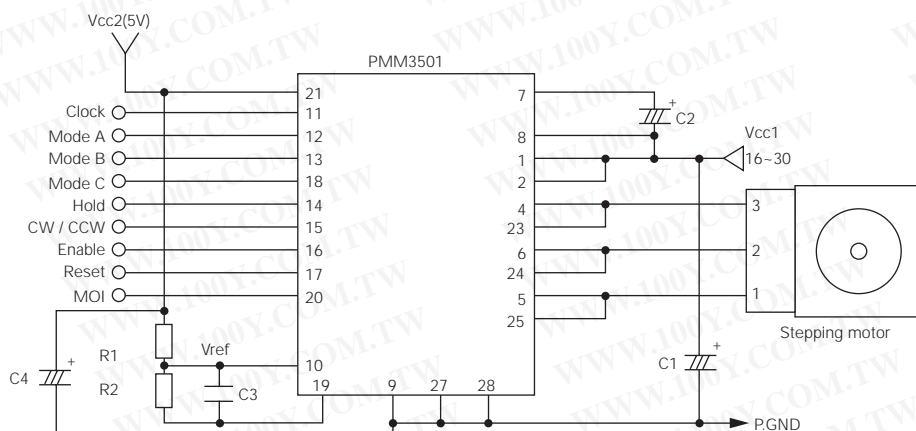

Recommended circuit part constants

C1	C2	C3	C4
470μF	6.8μF	0.1μF	10μF

- For the R1 and R2 constants, determine the V_{ref} voltage according to the following equation.

$$V_{ref} (V) = \text{motor current adjustment value (A/phase)} \times 0.41$$
 Notice that 100Ω is recommended for R2 due to the configuration of the internal circuit of the PMM3101.
- Place the GND side of the source by-pass capacitor of VCC1 (C1) as close to pins 27 and 28 as possible to reduce noise.