

# K9XXG08UXB

勝特力材料 886-3-5753170  
勝特力电子(上海) 86-21-54151736  
勝特力电子(深圳) 86-755-83298787  
[Http://www.100y.com.tw](http://www.100y.com.tw)

**INFORMATION IN THIS DOCUMENT IS PROVIDED IN RELATION TO SAMSUNG PRODUCTS, AND IS SUBJECT TO CHANGE WITHOUT NOTICE.**

**NOTHING IN THIS DOCUMENT SHALL BE CONSTRUED AS GRANTING ANY LICENSE, EXPRESS OR IMPLIED, BY ESTOPPEL OR OTHERWISE,**

**TO ANY INTELLECTUAL PROPERTY RIGHTS IN SAMSUNG PRODUCTS OR TECHNOLOGY. ALL INFORMATION IN THIS DOCUMENT IS PROVIDED**

**ON AS "AS IS" BASIS WITHOUT GUARANTEE OR WARRANTY OF ANY KIND.**

1. For updates or additional information about Samsung products, contact your nearest Samsung office.
2. Samsung products are not intended for use in life support, critical care, medical, safety equipment, or similar applications where Product failure could result in loss of life or personal or physical harm, or any military or defense application, or any governmental procurement to which special terms or provisions may apply.

\* Samsung Electronics reserves the right to change products or specification without notice.

Document Title

## 128M x 8 Bit NAND Flash Memory

Revision History

<u>Revision No</u>	<u>History</u>	<u>Draft Date</u>	<u>Remark</u>
0.0	1. Initial issue	May 26, 2006	Advance
1.0	1. 1.8V device is eliminated	Sep. 27, 2006	Final

勝特力材料 886-3-5753170  
勝特力电子(上海) 86-21-54151736  
勝特力电子(深圳) 86-755-83298787  
[Http://www.100y.com.tw](http://www.100y.com.tw)

The attached data sheets are prepared and approved by SAMSUNG Electronics. SAMSUNG Electronics CO., LTD. reserve the right to change the specifications. SAMSUNG Electronics will evaluate and reply to your requests and questions about device. If you have any questions, please contact the SAMSUNG branch office near your office.

## 128M x 8 Bit NAND Flash Memory

### PRODUCT LIST

Part Number	Vcc Range	Organization	PKG Type
K9F1G08U0B-P	2.70 ~ 3.60V	x8	TSOP1

### FEATURES

- Voltage Supply
  - 3.3V Device(K9F1G08U0B) : 2.70V ~ 3.60V
- Organization
  - Memory Cell Array : (128M + 4M) x 8bit
  - Data Register : (2K + 64) x 8bit
- Automatic Program and Erase
  - Page Program : (2K + 64)Byte
  - Block Erase : (128K + 4K)Byte
- Page Read Operation
  - Page Size : (2K + 64)Byte
  - Random Read : 25μs(Max.)
  - Serial Access : 25ns(Min.)
- Fast Write Cycle Time
  - Page Program time : 200μs(Typ.)
  - Block Erase Time : 1.5ms(Typ.)
- Command/Address/Data Multiplexed I/O Port
- Hardware Data Protection
  - Program/Erase Lockout During Power Transitions
- Reliable CMOS Floating-Gate Technology
  - Endurance : 100K Program/Erase Cycles(with 1bit/512Byte ECC)
  - Data Retention : 10 Years
- Command Driven Operation
- Intelligent Copy-Back with internal 1bit/528Byte EDC
- Unique ID for Copyright Protection
- Package :
  - K9F1G08U0B-PCB0/PIB0 : Pb-FREE PACKAGE
  - 48 - Pin TSOP I (12 x 20 / 0.5 mm pitch)

勝特力材料 886-3-5753170  
 勝特力电子(上海) 86-21-54151736  
 勝特力电子(深圳) 86-755-83298787  
[Http://www.100y.com.tw](http://www.100y.com.tw)

### GENERAL DESCRIPTION

Offered in 128Mx8bit, the K9F1G08U0B is a 1G-bit NAND Flash Memory with spare 32M-bit. Its NAND cell provides the most cost-effective solution for the solid state application market. A program operation can be performed in typical 200μs on the (2K+64)Byte page and an erase operation can be performed in typical 1.5ms on a (128K+4K)Byte block. Data in the data register can be read out at 25ns cycle time per Byte. The I/O pins serve as the ports for address and data input/output as well as command input. The on-chip write controller automates all program and erase functions including pulse repetition, where required, and internal verification and margining of data. Even the write-intensive systems can take advantage of the K9F1G08U0B's extended reliability of 100K program/erase cycles by providing ECC(Error Correcting Code) with real time mapping-out algorithm. The K9F1G08U0B is an optimum solution for large nonvolatile storage applications such as solid state file storage and other portable applications requiring non-volatility.

PIN CONFIGURATION (TSOP1)

K9F1G08U0B-PCB0/PIB0

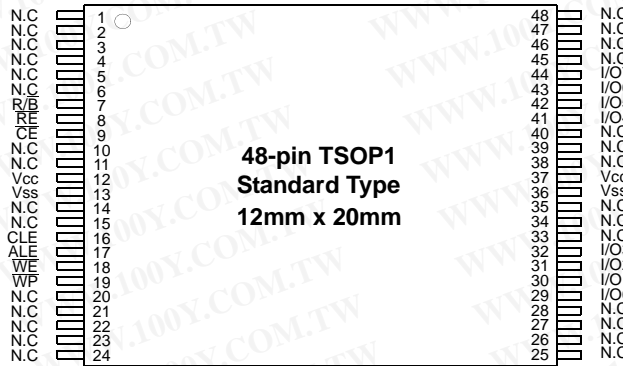

勝特力材料 886-3-5753170  
 勝特力电子(上海) 86-21-54151736  
 勝特力电子(深圳) 86-755-83298787  
[Http://www.100y.com.tw](http://www.100y.com.tw)

PACKAGE DIMENSIONS

48-PIN LEAD FREE PLASTIC THIN SMALL OUT-LINE PACKAGE TYPE(I)

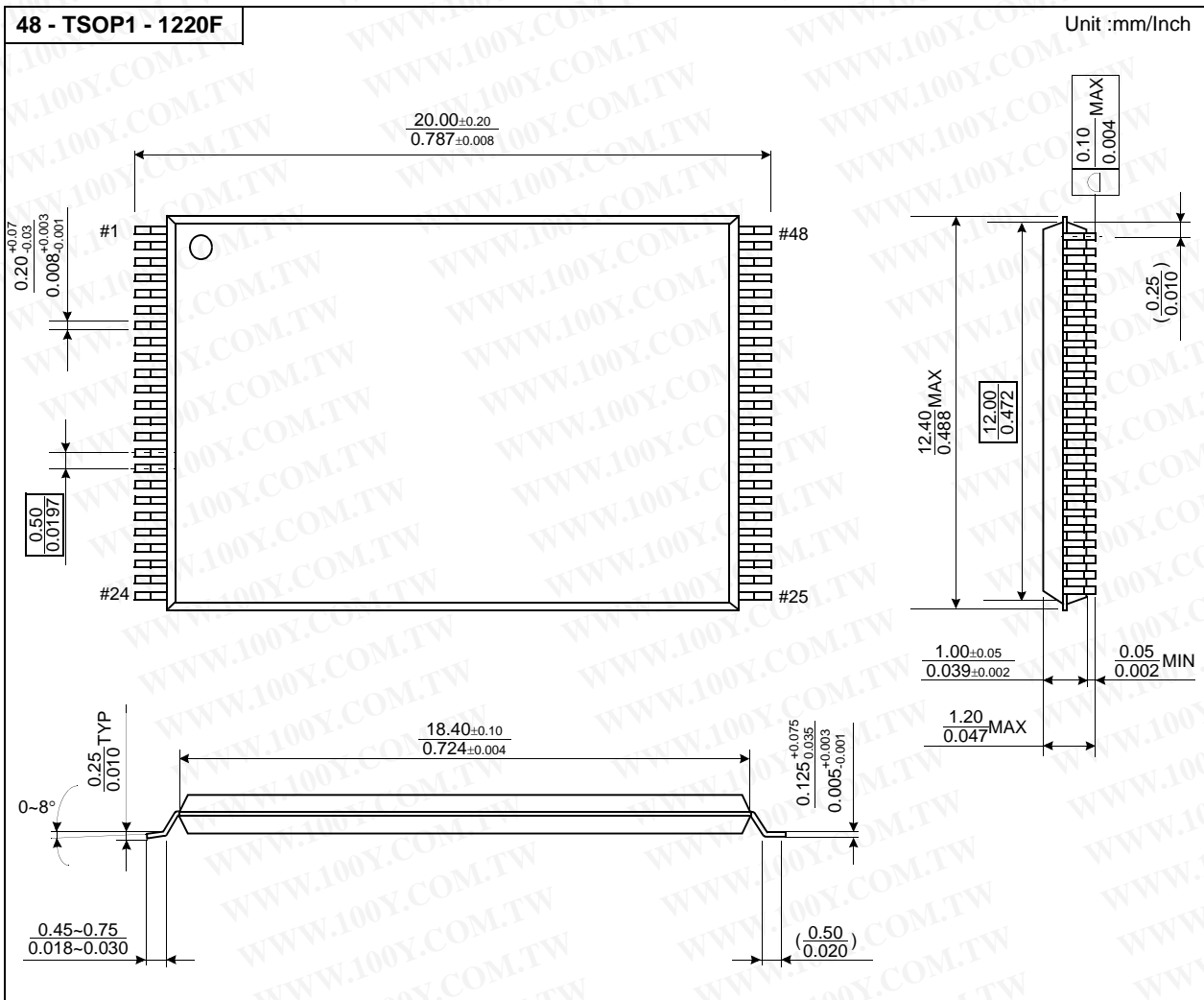

## PIN DESCRIPTION

Pin Name	Pin Function
I/O <sub>0</sub> ~ I/O <sub>7</sub>	<b>DATA INPUTS/OUTPUTS</b> The I/O pins are used to input command, address and data, and to output data during read operations. The I/O pins float to high-z when the chip is deselected or when the outputs are disabled.
CLE	<b>COMMAND LATCH ENABLE</b> The CLE input controls the activating path for commands sent to the command register. When active high, commands are latched into the command register through the I/O ports on the rising edge of the WE signal.
ALE	<b>ADDRESS LATCH ENABLE</b> The ALE input controls the activating path for address to the internal address registers. Addresses are latched on the rising edge of $\overline{WE}$ with ALE high.
$\overline{CE}$	<b>CHIP ENABLE</b> The $\overline{CE}$ input is the device selection control. When the device is in the Busy state, $\overline{CE}$ high is ignored, and the device does not return to standby mode in program or erase operation.
$\overline{RE}$	<b>READ ENABLE</b> The $\overline{RE}$ input is the serial data-out control, and when active drives the data onto the I/O bus. Data is valid tREA after the falling edge of $\overline{RE}$ which also increments the internal column address counter by one.
$\overline{WE}$	<b>WRITE ENABLE</b> The $\overline{WE}$ input controls writes to the I/O port. Commands, address and data are latched on the rising edge of the $\overline{WE}$ pulse.
$\overline{WP}$	<b>WRITE PROTECT</b> The $\overline{WP}$ pin provides inadvertent program/erase protection during power transitions. The internal high voltage generator is reset when the $\overline{WP}$ pin is active low.
R/ $\overline{B}$	<b>READY/BUSY OUTPUT</b> The R/ $\overline{B}$ output indicates the status of the device operation. When low, it indicates that a program, erase or random read operation is in process and returns to high state upon completion. It is an open drain output and does not float to high-z condition when the chip is deselected or when outputs are disabled.
Vcc	<b>POWER</b> Vcc is the power supply for device.
Vss	<b>GROUND</b>
N.C	<b>NO CONNECTION</b> Lead is not internally connected.

**NOTE** : Connect all Vcc and Vss pins of each device to common power supply outputs.  
Do not leave Vcc or Vss disconnected.

勝特力材料 886-3-5753170  
 勝特力电子(上海) 86-21-54151736  
 勝特力电子(深圳) 86-755-83298787  
[Http://www.100y.com.tw](http://www.100y.com.tw)

Figure 1. K9F1G08U0B Functional Block Diagram

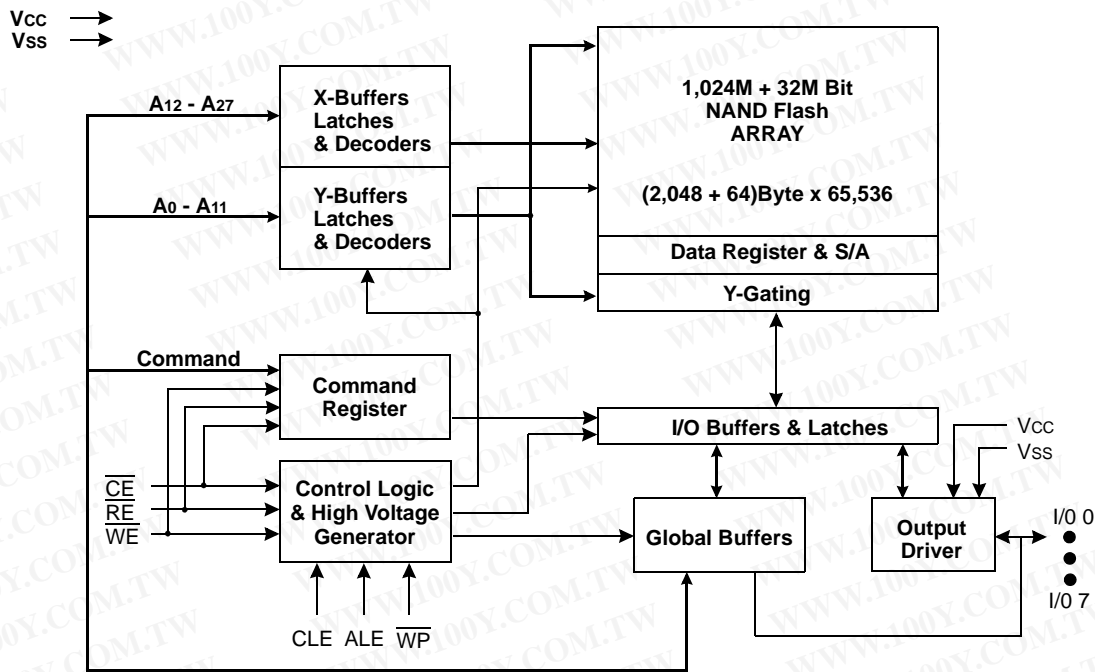
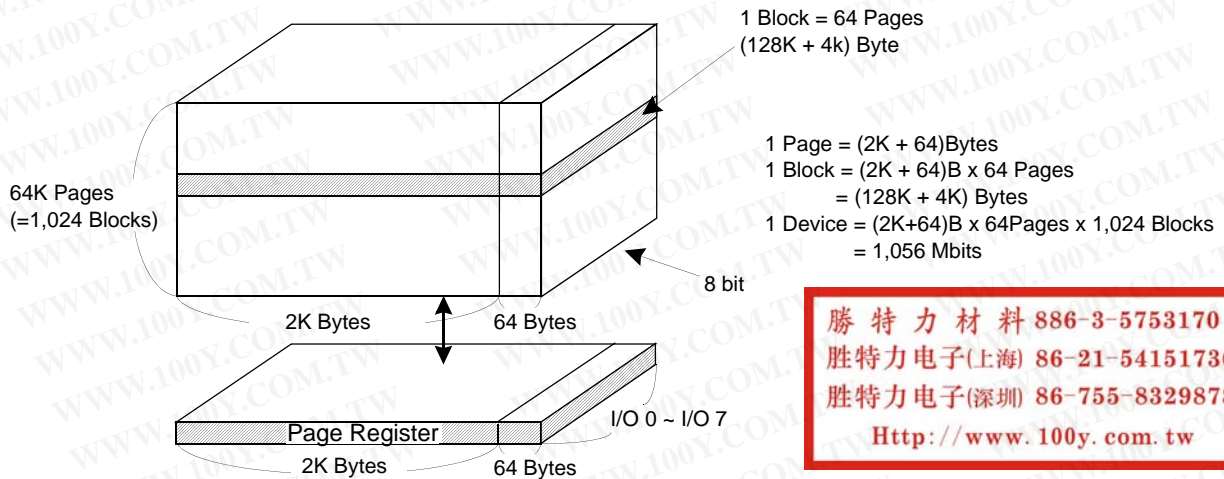

Figure 2. K9F1G08U0B Array Organization



	I/O 0	I/O 1	I/O 2	I/O 3	I/O 4	I/O 5	I/O 6	I/O 7	
1st Cycle	A0	A1	A2	A3	A4	A5	A6	A7	Column Address
2nd Cycle	A8	A9	A10	A11	*L	*L	*L	*L	Column Address
3rd Cycle	A12	A13	A14	A15	A16	A17	A18	A19	Row Address
4th Cycle	A20	A21	A22	A23	A24	A25	A26	A27	Row Address

NOTE : Column Address : Starting Address of the Register.

\* L must be set to "Low".

\* The device ignores any additional input of address cycles than required.

## Product Introduction

The K9F1G08U0B is a 1,056Mbit(1,107,296,256 bit) memory organized as 65,536 rows(pages) by 2,112x8 columns. Spare 64x8 columns are located from column address of 2,048~2,111. A 2,112-byte data register is connected to memory cell arrays accommodating data transfer between the I/O buffers and memory during page read and page program operations. The memory array is made up of 32 cells that are serially connected to form a NAND structure. Each of the 32 cells resides in a different page. A block consists of two NAND structured strings. A NAND structure consists of 32 cells. Total 1,081,344 NAND cells reside in a block. The program and read operations are executed on a page basis, while the erase operation is executed on a block basis. The memory array consists of 1,024 separately erasable 128K-byte blocks. It indicates that the bit by bit erase operation is prohibited on the K9F1G08U0B.

The K9F1G08U0B has addresses multiplexed into 8 I/Os. This scheme dramatically reduces pin counts and allows system upgrades to future densities by maintaining consistency in system board design. Command, address and data are all written through I/O's by bringing WE to low while CE is low. Those are latched on the rising edge of WE. Command Latch Enable(CLE) and Address Latch Enable(ALE) are used to multiplex command and address respectively, via the I/O pins. Some commands require one bus cycle. For example, Reset Command, Status Read Command, etc require just one cycle bus. Some other commands, like page read and block erase and page program, require two cycles: one cycle for setup and the other cycle for execution. The 132M byte physical space requires 28 addresses, thereby requiring four cycles for addressing : 2 cycles of column address, 2 cycles of row address, in that order. Page Read and Page Program need the same four address cycles following the required command input. In Block Erase operation, however, only the two row address cycles are used. Device operations are selected by writing specific commands into the command register. Table 1 defines the specific commands of the K9F1G08U0B.

In addition to the enhanced architecture and interface, the device incorporates copy-back program feature from one page to another page without need for transporting the data to and from the external buffer memory. Since the time-consuming serial access and data-input cycles are removed, system performance for solid-state disk application is significantly increased.

**Table 1. Command Sets**

Function	1st Cycle	2nd Cycle	Acceptable Command during Busy
Read	00h	30h	
Read for Copy Back	00h	35h	
Read ID	90h	-	
Reset	FFh	-	O
Page Program	80h	10h	
Copy-Back Program	85h	10h	
Block Erase	60h	D0h	
Random Data Input <sup>(1)</sup>	85h	-	
Random Data Output <sup>(1)</sup>	05h	E0h	
Read Status	70h		O
Read EDC Status <sup>(2)</sup>	7Bh		O

**NOTE** : 1. Random Data Input/Output can be executed in a page.

2. Read EDC Status is only available on Copy Back operation.

**Caution** : Any undefined command inputs are prohibited except for above command set of Table 1.

勝特力材料 886-3-5753170  
 勝特力电子(上海) 86-21-54151736  
 勝特力电子(深圳) 86-755-83298787  
[Http://www.100y.com.tw](http://www.100y.com.tw)

## ABSOLUTE MAXIMUM RATINGS

Parameter		Symbol	Rating		Unit
			3.3V Device		
Voltage on any pin relative to VSS		V <sub>CC</sub>	-0.6 to +4.6		V
		V <sub>IN</sub>	-0.6 to +4.6		
		V <sub>I/O</sub>	-0.6 to V <sub>CC</sub> + 0.3 (< 4.6V)		
Temperature Under Bias	K9XXG08XXB-XCB0	T <sub>BIAS</sub>	-10 to +125		°C
	K9XXG08XXB-XIB0		-40 to +125		
Storage Temperature	K9XXG08XXB-XCB0	T <sub>STG</sub>	-65 to +150		°C
	K9XXG08XXB-XIB0				
Short Circuit Current		I <sub>OS</sub>	5		mA

## NOTE :

- Minimum DC voltage is -0.6V on input/output pins. During transitions, this level may undershoot to -2.0V for periods <30ns. Maximum DC voltage on input/output pins is V<sub>CC</sub>+0.3V which, during transitions, may overshoot to V<sub>CC</sub>+2.0V for periods <20ns.
- Permanent device damage may occur if ABSOLUTE MAXIMUM RATINGS are exceeded. Functional operation should be restricted to the conditions as detailed in the operational sections of this data sheet. Exposure to absolute maximum rating conditions for extended periods may affect reliability.

## RECOMMENDED OPERATING CONDITIONS

(Voltage reference to GND, K9F1G08U0B-XCB0 :T<sub>A</sub>=0 to 70°C, K9F1G0808B-XIB0:T<sub>A</sub>=-40 to 85°C)

Parameter	Symbol	K9F1G08U0B(3.3V)			Unit
		Min	Typ.	Max	
Supply Voltage	V <sub>CC</sub>	2.7	3.3	3.6	V
Supply Voltage	V <sub>SS</sub>	0	0	0	V

## DC AND OPERATING CHARACTERISTICS(Recommended operating conditions otherwise noted.)

Parameter		Symbol	Test Conditions	K9F1G08U0B(3.3V)			Unit
				Min	Typ	Max	
Operating Current	Page Read with Serial Access	I <sub>CC1</sub>	t <sub>RC</sub> =25ns CE=V <sub>IL</sub> , I <sub>OUT</sub> =0mA	-	15	30	mA
	Program	I <sub>CC2</sub>	-	-	-		
	Erase	I <sub>CC3</sub>	-	-	-		
Stand-by Current(TTL)		I <sub>SB1</sub>	CE=V <sub>IH</sub> , WP=0V/V <sub>CC</sub>	-	-	1	μA
Stand-by Current(CMOS)		I <sub>SB2</sub>	CE=V <sub>CC</sub> -0.2, WP=0V/V <sub>CC</sub>	-	10	50	
Input Leakage Current		I <sub>LI</sub>	V <sub>IN</sub> =0 to V <sub>CC</sub> (max)	-	-	±10	μA
Output Leakage Current		I <sub>LO</sub>	V <sub>OUT</sub> =0 to V <sub>CC</sub> (max)	-	-	±10	
Input High Voltage		V <sub>IH</sub> <sup>(1)</sup>	-	0.8xV <sub>CC</sub>	-	V <sub>CC</sub> +0.3	V
Input Low Voltage, All inputs		V <sub>IL</sub> <sup>(1)</sup>	-	-0.3	-	0.2xV <sub>CC</sub>	
Output High Voltage Level		V <sub>OH</sub>	K9F1G08U0A :I <sub>OH</sub> =-400μA	2.4	-	-	
Output Low Voltage Level		V <sub>OL</sub>	K9F1G08U0A :I <sub>OL</sub> =2.1mA	-	-	0.4	
Output Low Current(R/B)		I <sub>OL</sub> (R/B)	K9F1G08U0A :V <sub>OL</sub> =0.4V	8	10	-	mA

- NOTE : 1. V<sub>IL</sub> can undershoot to -0.4V and V<sub>IH</sub> can overshoot to V<sub>CC</sub> +0.4V for durations of 20 ns or less.  
2. Typical value is measured at V<sub>CC</sub>=3.3V, T<sub>A</sub>=25°C. Not 100% tested.

勝特力材料 886-3-5753170  
 勝特力电子(上海) 86-21-54151736  
 勝特力电子(深圳) 86-755-83298787  
[Http://www.100y.com.tw](http://www.100y.com.tw)

VALID BLOCK

Parameter	Symbol	Min	Typ.	Max	Unit
K9F1G08U0B	NvB	1,004	-	1,024	Blocks

NOTE :

1. The device may include initial invalid blocks when first shipped. Additional invalid blocks may develop while being used. The number of valid blocks is presented with both cases of invalid blocks considered. Invalid blocks are defined as blocks that contain one or more bad bits. Do not erase or program factory-marked bad blocks. Refer to the attached technical notes for appropriate management of invalid blocks.
2. The 1st block, which is placed on 00h block address, is guaranteed to be a valid block up to 1K program/erase cycles with 1bit/512Byte ECC.

AC TEST CONDITION

(K9F1G08U0B-XCB0 :TA=0 to 70°C, K9F1G08U0B-XIB0:TA=-40 to 85°C, K9F1G08U0B : Vcc=2.7V~3.6V unless otherwise noted)

Parameter	K9F1G08U0B
Input Pulse Levels	0V to Vcc
Input Rise and Fall Times	5ns
Input and Output Timing Levels	Vcc/2
Output Load	1 TTL GATE and CL=50pF

CAPACITANCE(TA=25°C, VCC=3.3V, f=1.0MHz)

Item	Symbol	Test Condition	Min	Max	Unit
Input/Output Capacitance	C <sub>I/O</sub>	V <sub>IL</sub> =0V	-	10	pF
Input Capacitance	C <sub>IN</sub>	V <sub>IN</sub> =0V	-	10	pF

NOTE : Capacitance is periodically sampled and not 100% tested.

MODE SELECTION

CLE	ALE	CE	WE	RE	WP	Mode	
H	L	L		H	X	Read Mode	Command Input
L	H	L		H	X		Address Input(4clock)
H	L	L		H	H	Write Mode	Command Input
L	H	L		H	H		Address Input(4clock)
L	L	L		H	H	Data Input	
L	L	L	H		X	Data Output	
X	X	X	X	H	X	During Read(Busy)	
X	X	X	X	X	H	During Program(Busy)	
X	X	X	X	X	H	During Erase(Busy)	
X	X <sup>(1)</sup>	X	X	X	L	Write Protect	
X	X	H	X	X	0V/Vcc <sup>(2)</sup>	Stand-by	

NOTE : 1. X can be V<sub>IL</sub> or V<sub>IH</sub>.

2. WP should be biased to CMOS high or CMOS low for standby.

勝特力材料 886-3-5753170  
 勝特力电子(上海) 86-21-54151736  
 勝特力电子(深圳) 86-755-83298787  
[Http://www.100y.com.tw](http://www.100y.com.tw)

## Program / Erase Characteristics

Parameter	Symbol	Min	Typ	Max	Unit
Program Time	tPROG	-	200	700	μs
Dummy Busy Time for Two-Plane Page Program	tDBSY	-	0.5	1	μs
Number of Partial Program Cycles	Nop	-	-	4	cycles
Block Erase Time	tBERS	-	1.5	2	ms

NOTE : 1. Typical value is measured at Vcc=3.3V, TA=25°C. Not 100% tested.

2. Typical program time is defined as the time within which more than 50% of the whole pages are programmed at 3.3V Vcc and 25°C temperature.

## AC Timing Characteristics for Command / Address / Data Input

Parameter	Symbol	Min	Max	Unit
CLE Setup Time	tCLS <sup>(1)</sup>	12	-	ns
CLE Hold Time	tCLH	5	-	ns
$\overline{\text{CE}}$ Setup Time	tCS <sup>(1)</sup>	20	-	ns
$\overline{\text{CE}}$ Hold Time	tCH	5	-	ns
$\overline{\text{WE}}$ Pulse Width	tWP	12	-	ns
ALE Setup Time	tALS <sup>(1)</sup>	12	-	ns
ALE Hold Time	tALH	5	-	ns
Data Setup Time	tDS <sup>(1)</sup>	12	-	ns
Data Hold Time	tDH	5	-	ns
Write Cycle Time	tWC	25	-	ns
$\overline{\text{WE}}$ High Hold Time	tWH	10	-	ns
Address to Data Loading Time	tADL <sup>(2)</sup>	100	-	ns

NOTES : 1. The transition of the corresponding control pins must occur only once while  $\overline{\text{WE}}$  is held low

2. tADL is the time from the  $\overline{\text{WE}}$  rising edge of final address cycle to the  $\overline{\text{WE}}$  rising edge of first data cycle

勝特力材料 886-3-5753170  
 胜特力电子(上海) 86-21-54151736  
 胜特力电子(深圳) 86-755-83298787  
[Http://www.100y.com.tw](http://www.100y.com.tw)

## AC Characteristics for Operation

Parameter	Symbol	Min	Max	Unit
Data Transfer from Cell to Register	tR	-	25	μs
ALE to $\overline{RE}$ Delay	tAR	10	-	ns
CLE to $\overline{RE}$ Delay	tCLR	10	-	ns
Ready to $\overline{RE}$ Low	tRR	20	-	ns
$\overline{RE}$ Pulse Width	tRP	12	-	ns
$\overline{WE}$ High to Busy	tWB	-	100	ns
Read Cycle Time	tRC	25	-	ns
$\overline{RE}$ Access Time	tREA	-	20	ns
$\overline{CE}$ Access Time	tCEA	-	25	ns
$\overline{RE}$ High to Output Hi-Z	tRHZ	-	100	ns
$\overline{CE}$ High to Output Hi-Z	tCHZ	-	30	ns
$\overline{CE}$ High to ALE or CLE Don't Care	tCSD	10	-	ns
$\overline{RE}$ High to Output Hold	tRHOH	15	-	ns
$\overline{RE}$ Low to Output Hold	tRLOH	5	-	ns
$\overline{CE}$ High to Output Hold	tCOH	15	-	ns
$\overline{RE}$ High Hold Time	tREH	10	-	ns
Output Hi-Z to $\overline{RE}$ Low	tIR	0	-	ns
$\overline{RE}$ High to $\overline{WE}$ Low	tRHW	100	-	ns
$\overline{WE}$ High to $\overline{RE}$ Low	tWHR	60	-	ns
Device Resetting Time(Read/Program/Erase)	tRST	-	5/10/500 <sup>(1)</sup>	μs

NOTE: 1. If reset command(FFh) is written at Ready state, the device goes into Busy for maximum 5μs.

勝特力材料 886-3-5753170  
 勝特力电子(上海) 86-21-54151736  
 勝特力电子(深圳) 86-755-83298787  
[Http://www.100y.com.tw](http://www.100y.com.tw)

**NAND Flash Technical Notes**

**Initial Invalid Block(s)**

Initial invalid blocks are defined as blocks that contain one or more initial invalid bits whose reliability is not guaranteed by Samsung. The information regarding the initial invalid block(s) is called the initial invalid block information. Devices with initial invalid block(s) have the same quality level as devices with all valid blocks and have the same AC and DC characteristics. An initial invalid block(s) does not affect the performance of valid block(s) because it is isolated from the bit line and the common source line by a select transistor. The system design must be able to mask out the initial invalid block(s) via address mapping. The 1st block, which is placed on 00h block address, is guaranteed to be a valid block up to 1K program/erase cycles with 1bit/512Byte ECC.

**Identifying Initial Invalid Block(s)**

All device locations are erased(FFh) except locations where the initial invalid block(s) information is written prior to shipping. The initial invalid block(s) status is defined by the 1st byte in the spare area. Samsung makes sure that either the 1st or 2nd page of every initial invalid block has non-FFh data at the column address of 2048. Since the initial invalid block information is also erasable in most cases, it is impossible to recover the information once it has been erased. Therefore, the system must be able to recognize the initial invalid block(s) based on the original initial invalid block information and create the initial invalid block table via the following suggested flow chart(Figure 3). Any intentional erasure of the original initial invalid block information is prohibited.

勝特力材料 886-3-5753170  
 勝特力电子(上海) 86-21-54151736  
 勝特力电子(深圳) 86-755-83298787  
[Http://www.100y.com.tw](http://www.100y.com.tw)

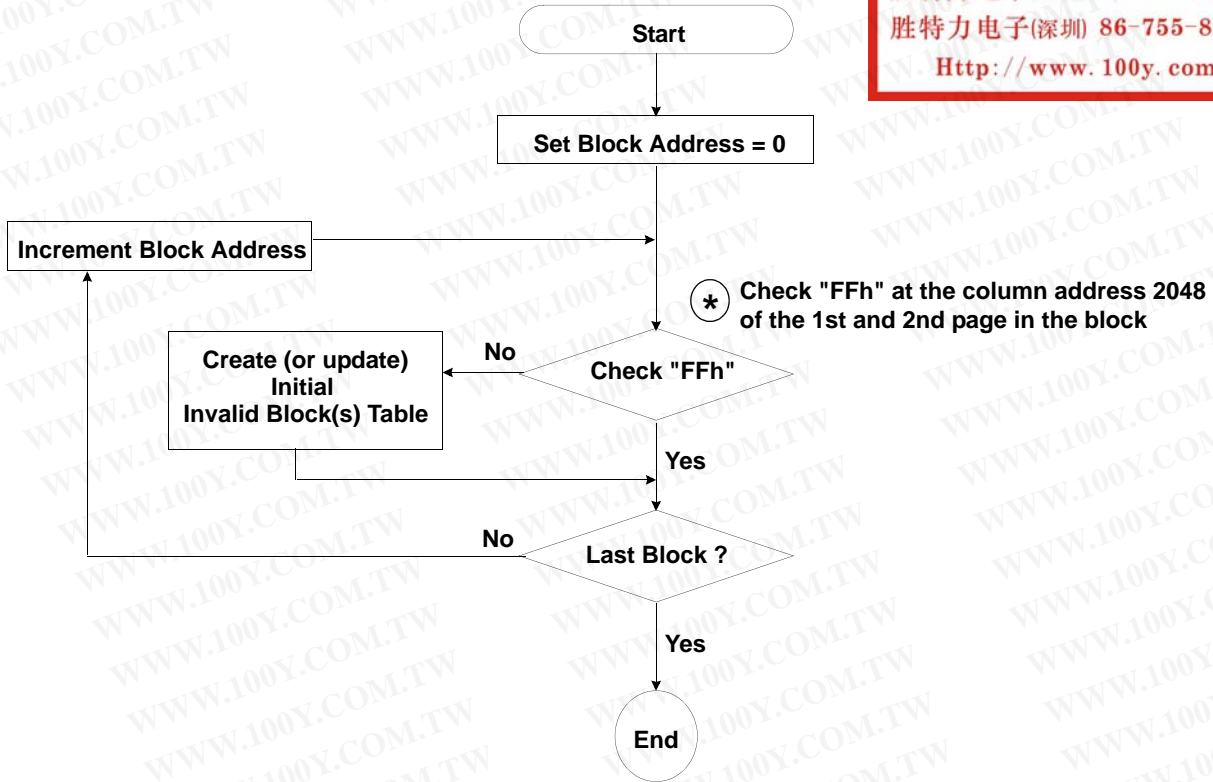

Figure 3. Flow chart to create initial invalid block table

**NAND Flash Technical Notes** (Continued)

**Error in write or read operation**

Within its life time, additional invalid blocks may develop with NAND Flash memory. Refer to the qualification report for the actual data. The following possible failure modes should be considered to implement a highly reliable system. In the case of status read failure after erase or program, block replacement should be done. Because program status fail during a page program does not affect the data of the other pages in the same block, block replacement can be executed with a page-sized buffer by finding an erased empty block and reprogramming the current target data and copying the rest of the replaced block. In case of Read, ECC must be employed. To improve the efficiency of memory space, it is recommended that the read or verification failure due to single bit error be reclaimed by ECC without any block replacement. The said additional block failure rate does not include those reclaimed blocks.

Failure Mode		Detection and Countermeasure sequence
Write	Erase Failure	Status Read after Erase --> Block Replacement
	Program Failure	Status Read after Program --> Block Replacement
Read	Single Bit Failure	Verify ECC -> ECC Correction

**ECC** : Error Correcting Code --> Hamming Code etc.  
 Example) 1bit correction & 2bit detection

**Program Flow Chart**

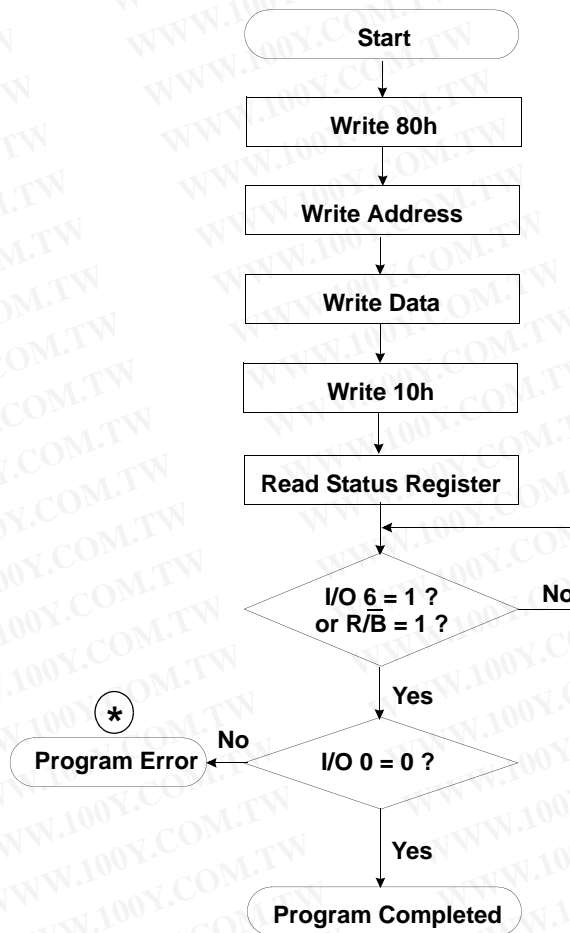

勝特力材料 886-3-5753170  
 勝特力电子(上海) 86-21-54151736  
 勝特力电子(深圳) 86-755-83298787  
[Http://www.100y.com.tw](http://www.100y.com.tw)

**\*** : If program operation results in an error, map out the block including the page in error and copy the target data to another block.

NAND Flash Technical Notes (Continued)

Erase Flow Chart

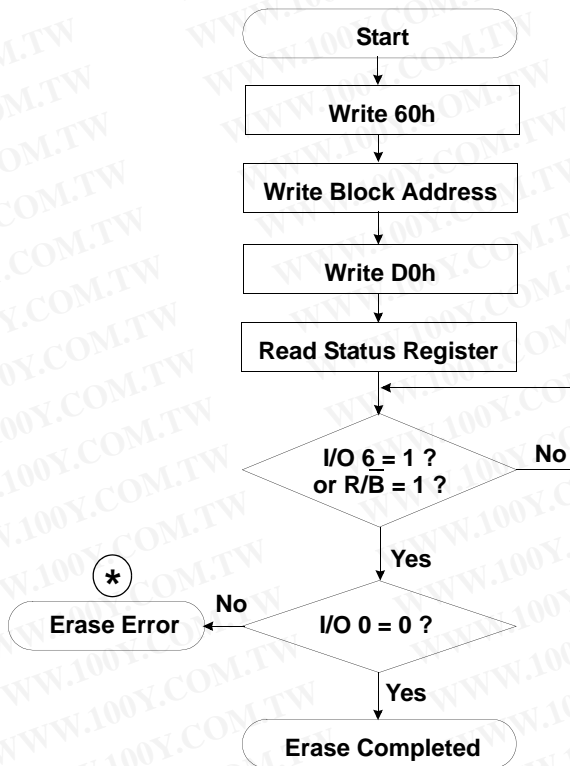

Read Flow Chart

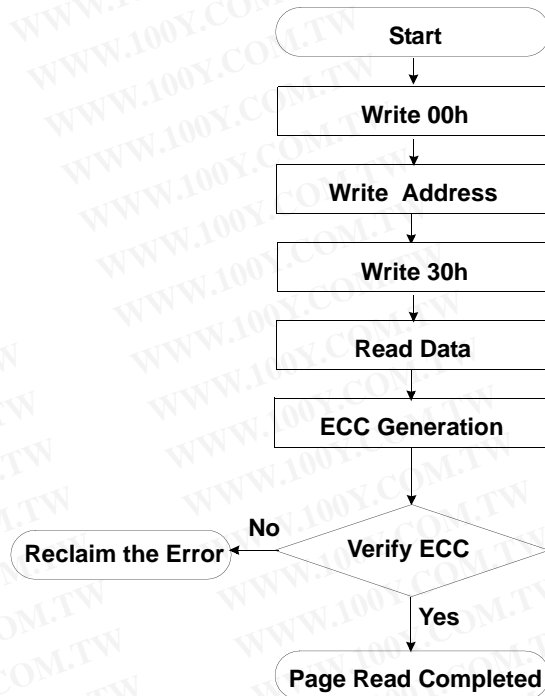

\* : If erase operation results in an error, map out the failing block and replace it with another block.

Block Replacement

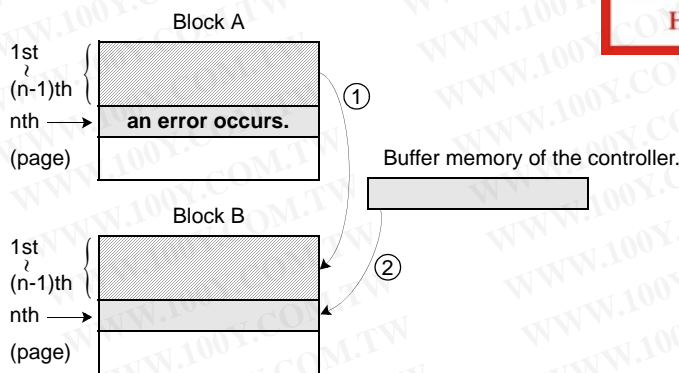

勝特力材料 886-3-5753170  
 勝特力电子(上海) 86-21-54151736  
 勝特力电子(深圳) 86-755-83298787  
[Http://www.100y.com.tw](http://www.100y.com.tw)

- \* Step1  
When an error happens in the nth page of the Block 'A' during erase or program operation.
- \* Step2  
Copy the data in the 1st ~ (n-1)th page to the same location of another free block. (Block 'B')
- \* Step3  
Then, copy the nth page data of the Block 'A' in the buffer memory to the nth page of the Block 'B'.
- \* Step4  
Do not erase or program to Block 'A' by creating an 'invalid block' table or other appropriate scheme.

**NAND Flash Technical Notes** (Continued)

**Copy-Back Operation with EDC & Sector Definition for EDC**

Generally, copy-back program is very powerful to move data stored in a page without utilizing any external memory. But, if the source page has one bit error due to charge loss or charge gain, then without EDC, the copy-back program operation could also accumulate bit errors.

K9F1G08U0B supports copy-back with EDC to prevent cumulative bit errors. To make EDC valid, the page program operation should be performed on either whole page(2112byte) or sector(528byte). **Modifying the data of a sector by Random Data Input before Copy-Back Program must be performed for the whole sector and is allowed only once per each sector. Any partial modification smaller than a sector corrupts the on-chip EDC codes.**

A 2,112-byte page is composed of 4 sectors of 528-byte and each 528-byte sector is composed of 512-byte main area and 16-byte spare area.

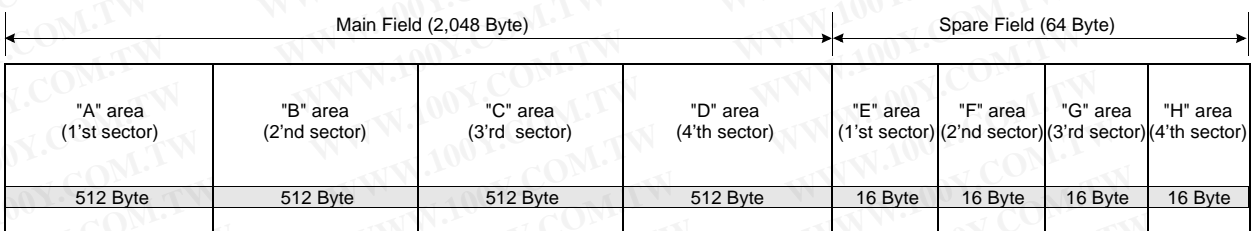
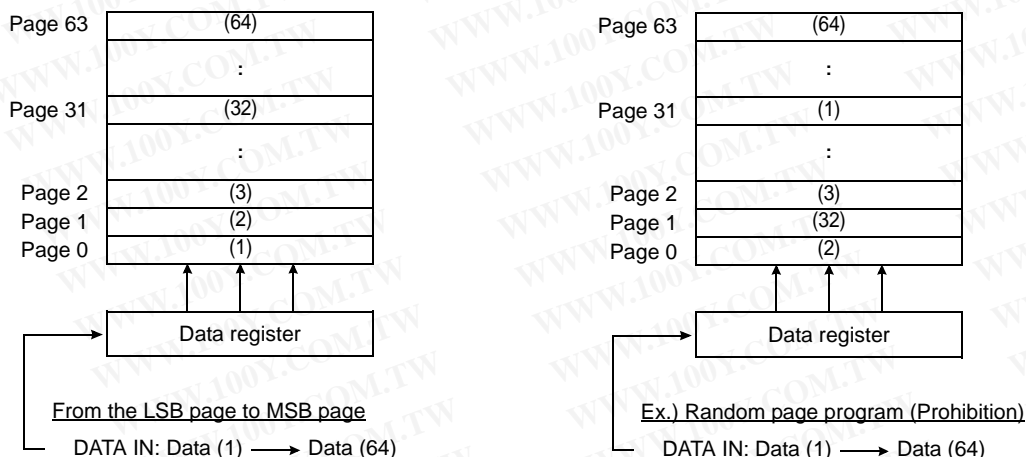

**Table 2. Definition of the 528-Byte Sector**

Sector	Main Field (Column 0~2,047)		Spare Field (Column 2,048~2,111)	
	Area Name	Column Address	Area Name	Column Address
1'st 528-Byte Sector	"A"	0 ~ 511	"E"	2,048 ~ 2,063
2'nd 528-Byte Sector	"B"	512 ~ 1,023	"F"	2,064 ~ 2,079
3'rd 528-Byte Sector	"C"	1,024 ~ 1,535	"G"	2,080 ~ 2,095
4'th 528-Byte Sector	"D"	1,536 ~ 2,047	"H"	2,096 ~ 2,111

**Addressing for program operation**

Within a block, the pages must be programmed consecutively from the LSB(least significant bit) page of the block to the MSB(most significant bit) pages of the block. Random page address programming is prohibited. In this case, the definition of LSB page is the LSB among the pages to be programmed. Therefore, LSB doesn't need to be page 0.



**System Interface Using  $\overline{CE}$  don't-care.**

For an easier system interface,  $\overline{CE}$  may be inactive during the data-loading or serial access as shown below. The internal 2,112byte data registers are utilized as separate buffers for this operation and the system design gets more flexible. In addition, for voice or audio applications which use slow cycle time on the order of  $\mu$ -seconds, de-activating  $\overline{CE}$  during the data-loading and serial access would provide significant savings in power consumption.

**Figure 4. Program Operation with  $\overline{CE}$  don't-care.**

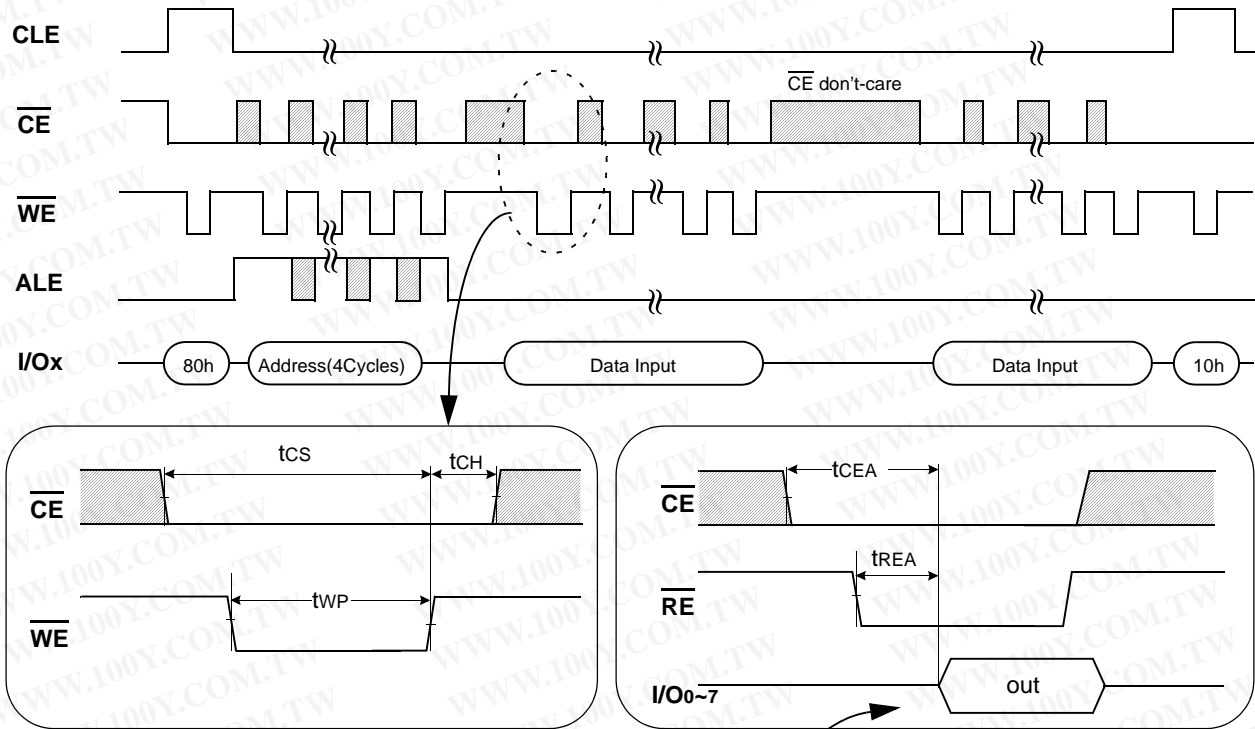

**Figure 5. Read Operation with  $\overline{CE}$  don't-care.**

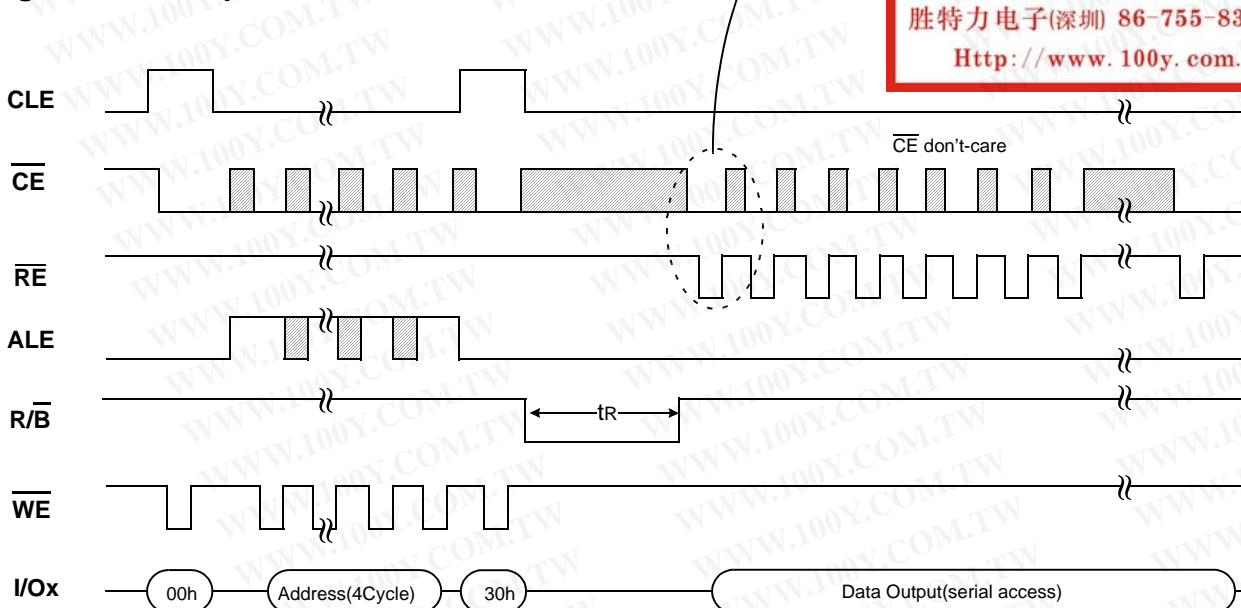

勝特力材料 886-3-5753170  
 勝特力电子(上海) 86-21-54151736  
 勝特力电子(深圳) 86-755-83298787  
[Http://www.100y.com.tw](http://www.100y.com.tw)

NOTE

Device	I/O	DATA	ADDRESS			
	I/Ox	Data In/Out	Col. Add1	Col. Add2	Row Add1	Row Add2
K9F1G08U0B	I/O 0 ~ I/O 7	~2112byte	A0~A7	A8~A11	A12~A19	A20~A27

Command Latch Cycle

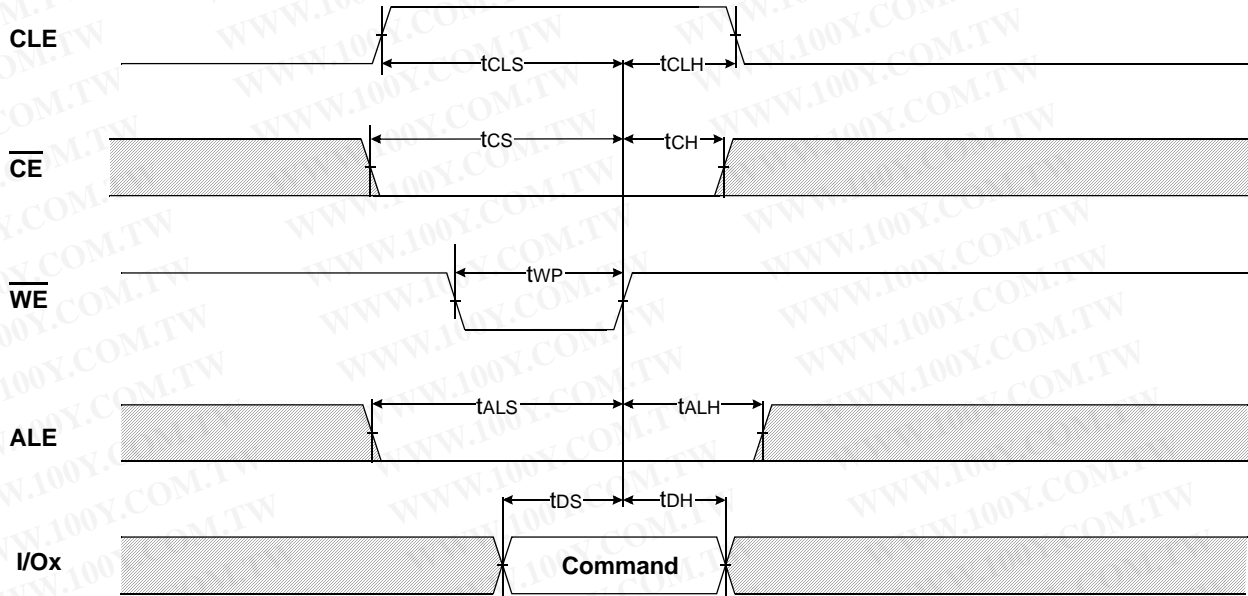

勝特力材料 886-3-5753170  
 勝特力电子(上海) 86-21-54151736  
 勝特力电子(深圳) 86-755-83298787  
[Http://www.100y.com.tw](http://www.100y.com.tw)

Address Latch Cycle

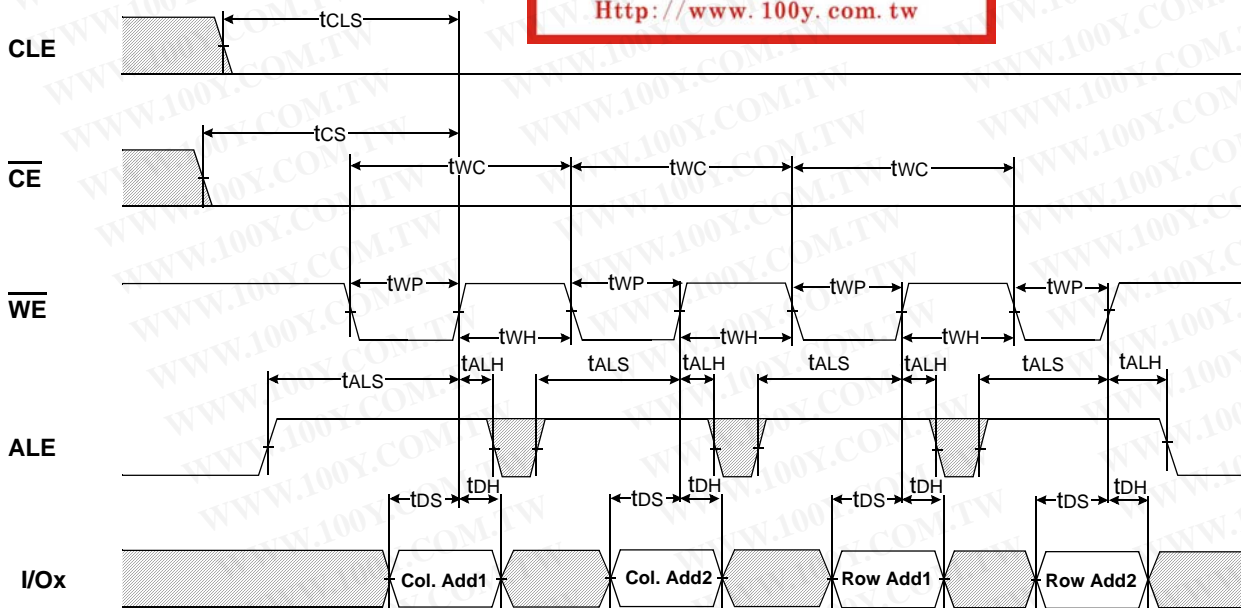

Input Data Latch Cycle

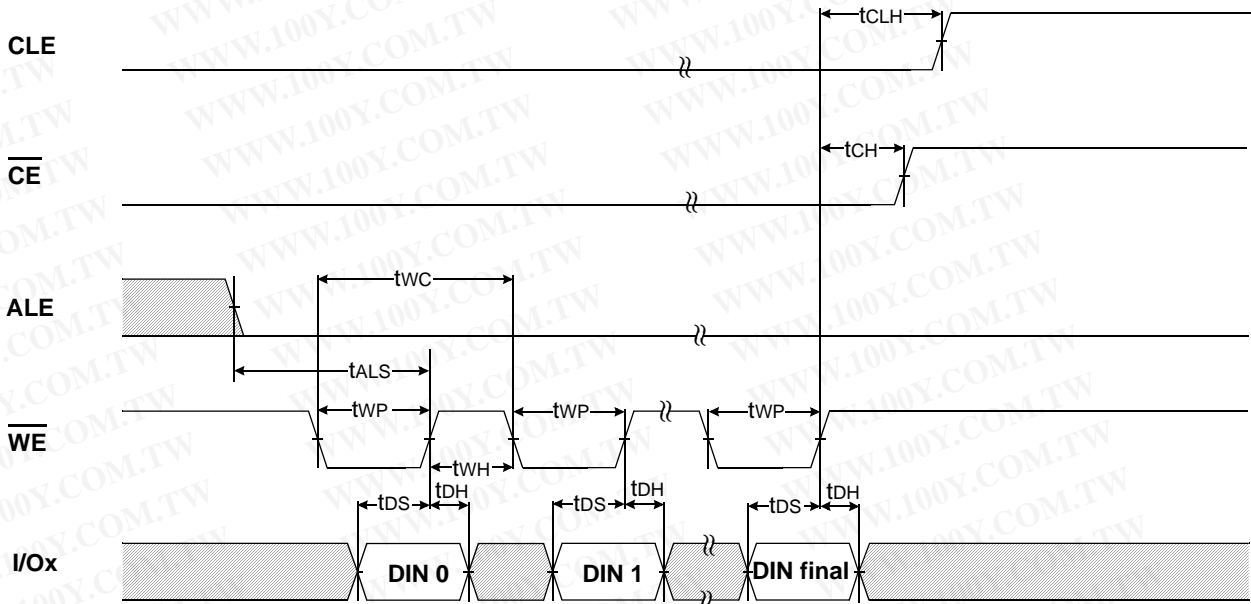

勝特力材料 886-3-5753170  
 勝特力电子(上海) 86-21-54151736  
 勝特力电子(深圳) 86-755-83298787  
[Http://www.100y.com.tw](http://www.100y.com.tw)

\* Serial Access Cycle after Read (CLE=L, WE=H, ALE=L)

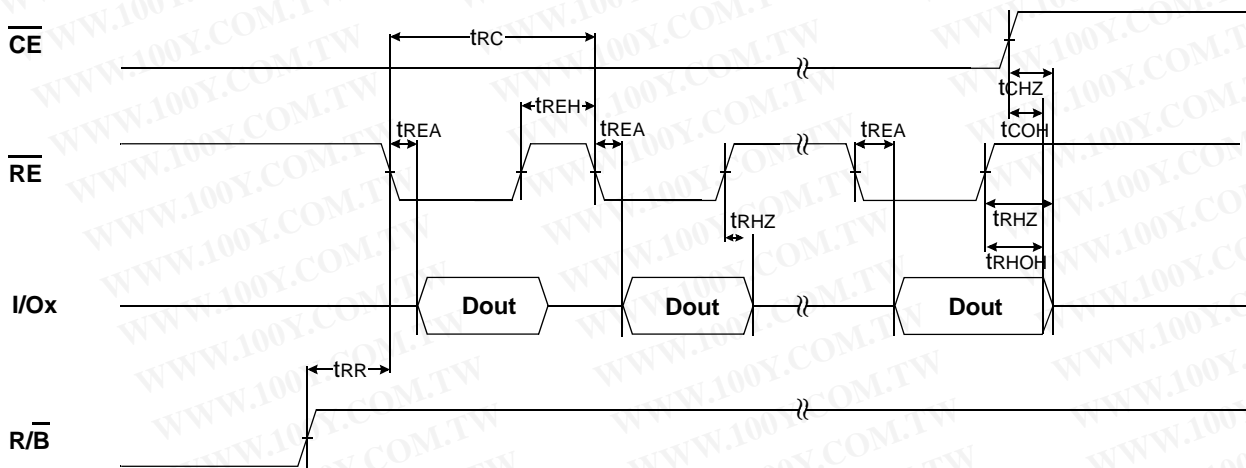

NOTES : Transition is measured at  $\pm 200\text{mV}$  from steady state voltage with load.  
 This parameter is sampled and not 100% tested.  
 $t_{RLOH}$  is valid when frequency is higher than 33MHz.  
 $t_{RH0H}$  starts to be valid when frequency is lower than 33MHz.

Serial Access Cycle after Read (EDO Type, CLE=L,  $\overline{WE}$ =H, ALE=L)

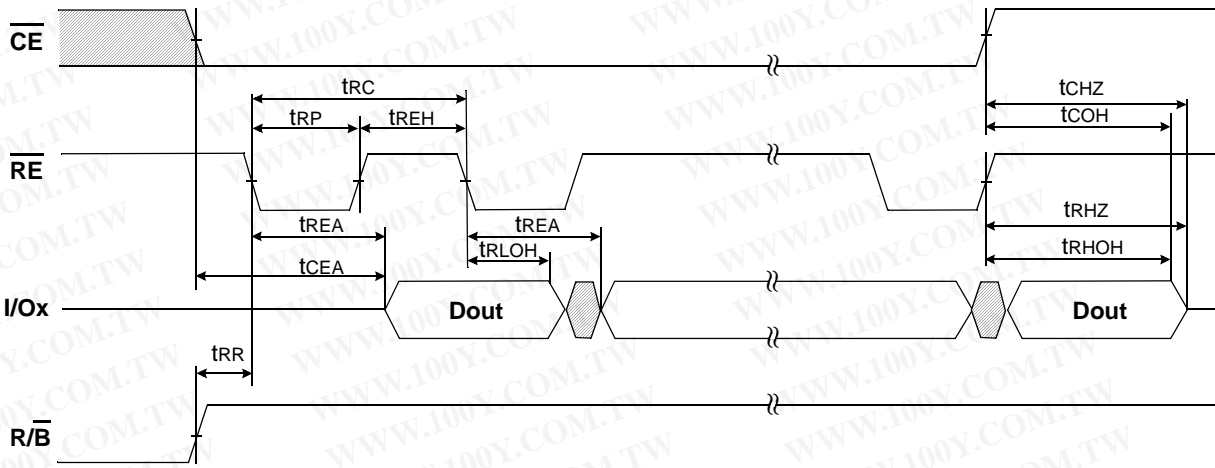

NOTES : Transition is measured at  $\pm 200\text{mV}$  from steady state voltage with load.  
 This parameter is sampled and not 100% tested.  
 tRLOH is valid when frequency is higher than 33MHz.  
 tRHOH starts to be valid when frequency is lower than 33MHz.

勝特力材料 886-3-5753170  
 勝特力电子(上海) 86-21-54151736  
 勝特力电子(深圳) 86-755-83298787  
[Http://www.100y.com.tw](http://www.100y.com.tw)

Status Read Cycle & EDC Status Read Cycle

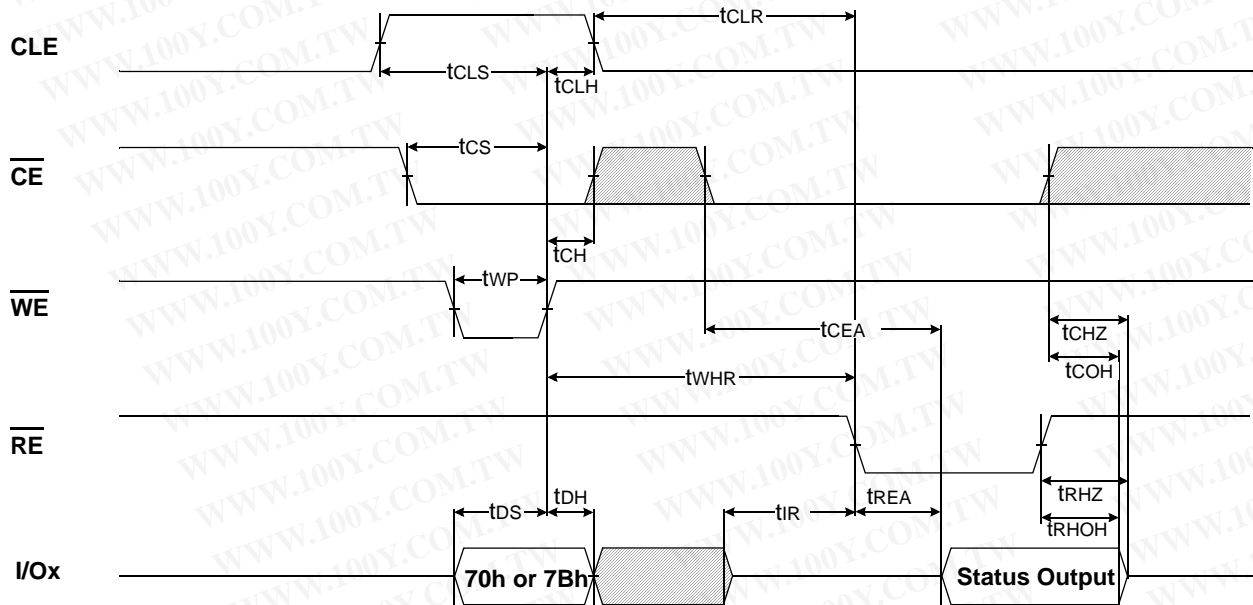

Read Operation

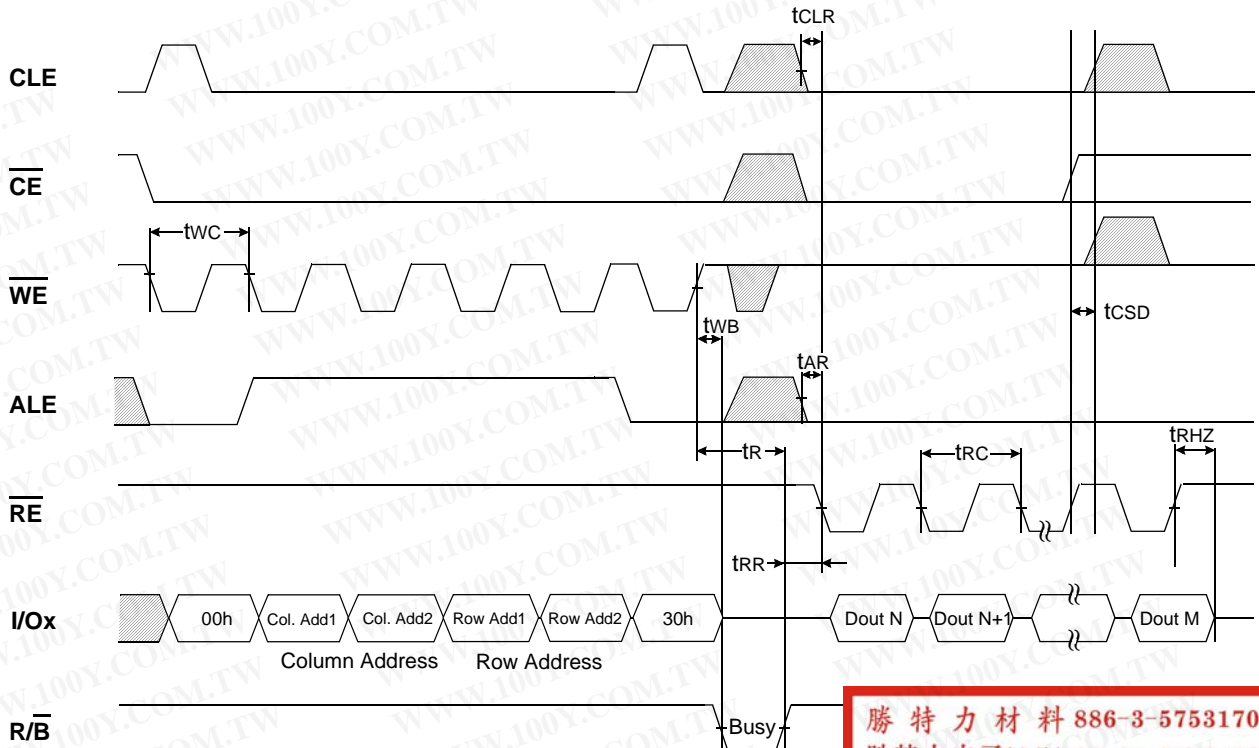

勝特力材料 886-3-5753170  
 勝特力电子(上海) 86-21-54151736  
 勝特力电子(深圳) 86-755-83298787  
[Http://www.100y.com.tw](http://www.100y.com.tw)

Read Operation (Intercepted by  $\overline{CE}$ )

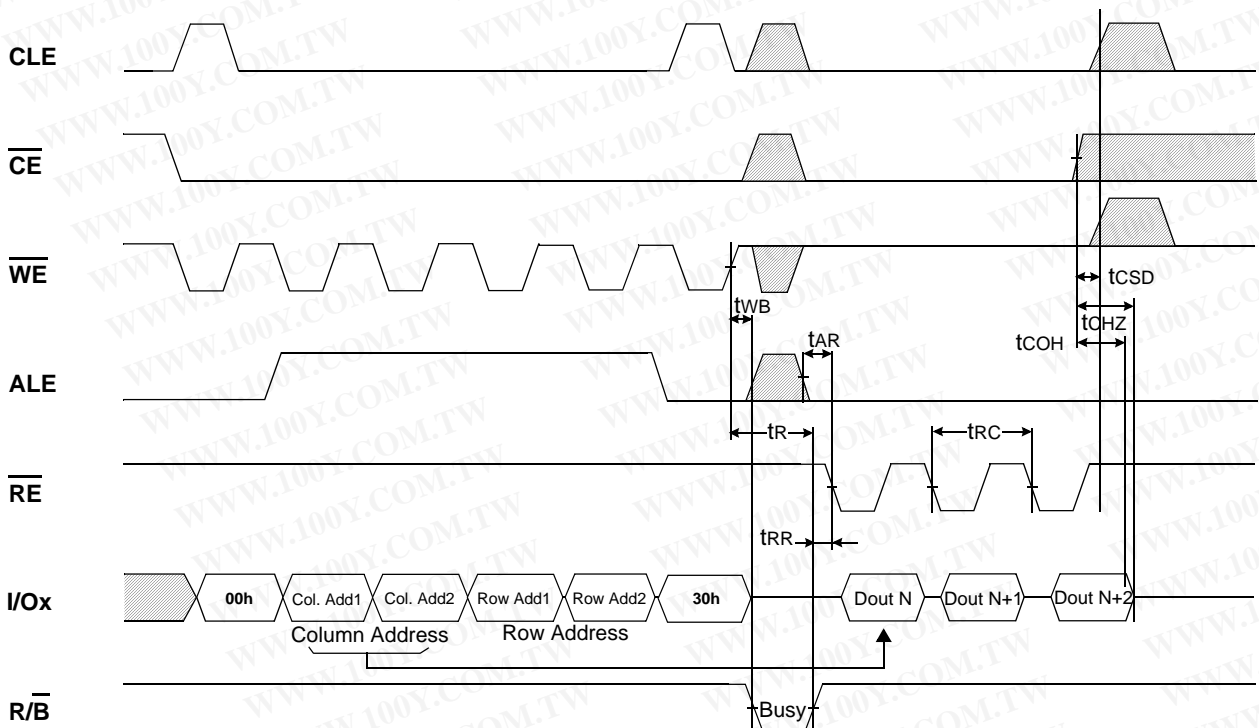

Random Data Output In a Page

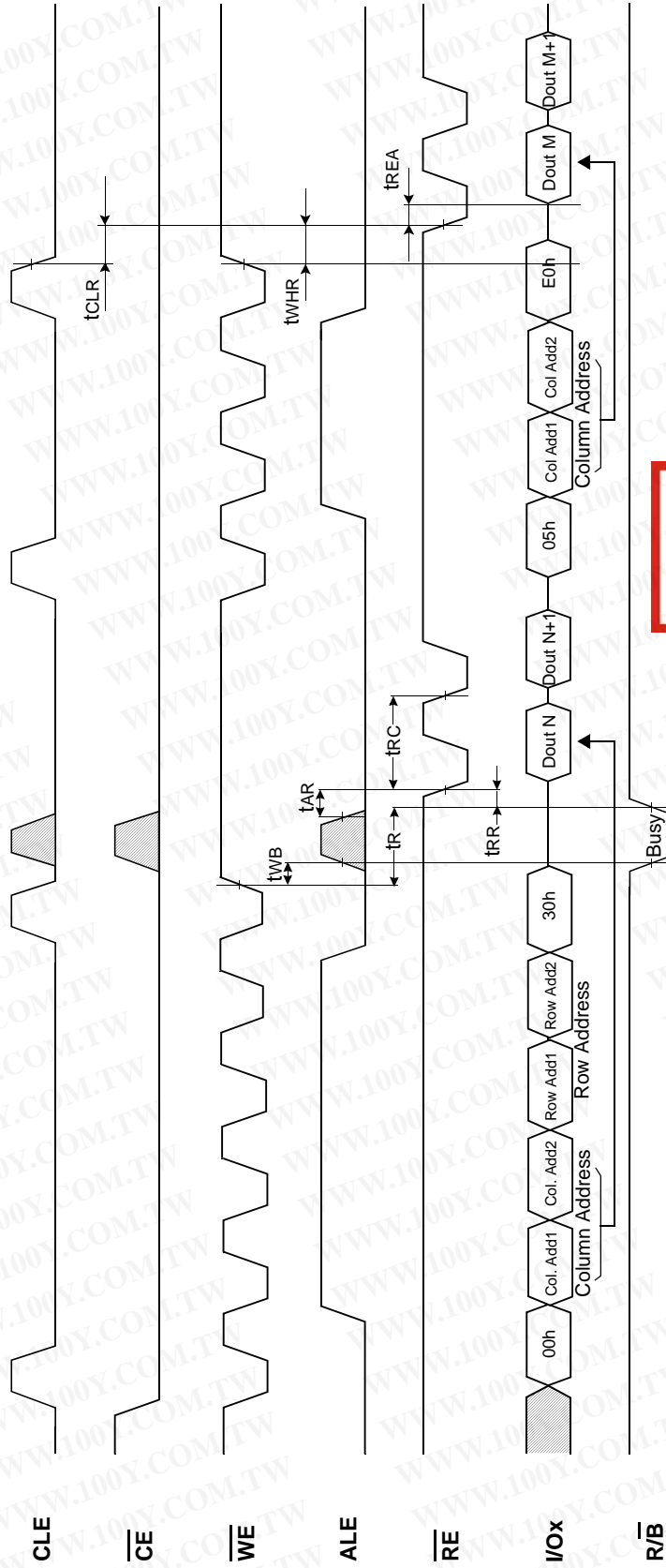

勝特力材料 886-3-5753170  
 勝特力电子(上海) 86-21-54151736  
 勝特力电子(深圳) 86-755-83298787  
[Http://www.100y.com.tw](http://www.100y.com.tw)

Page Program Operation

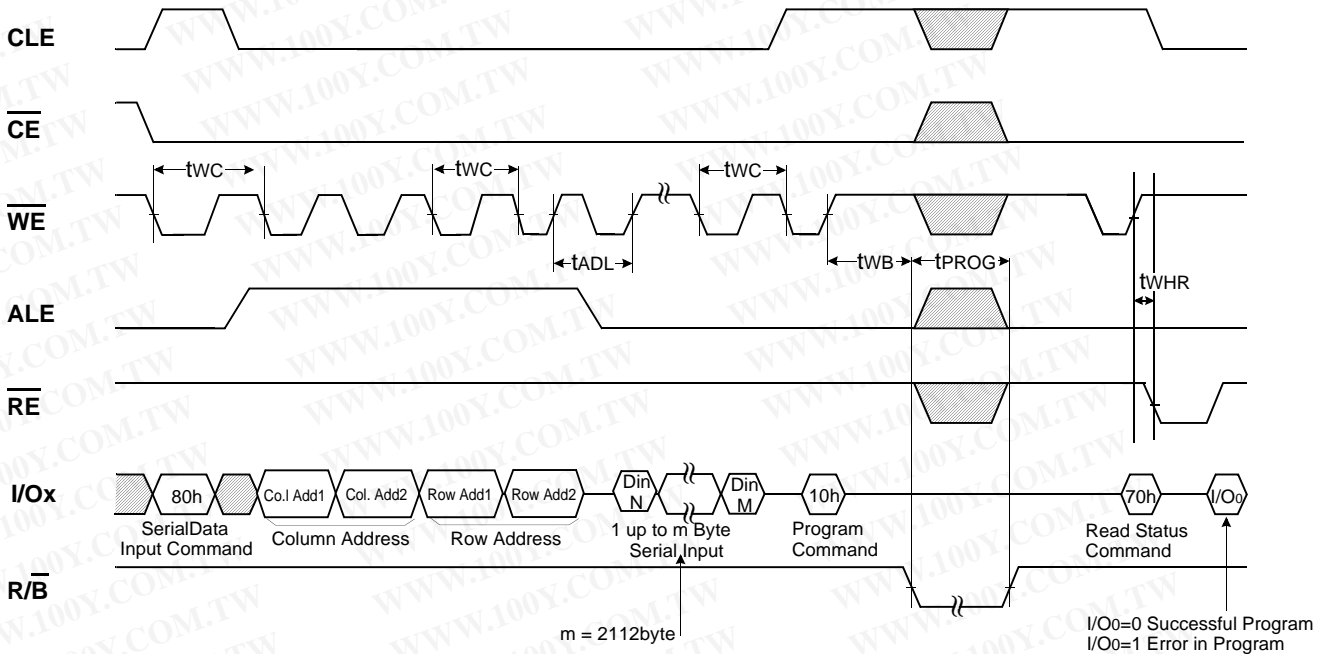

NOTES : tADL is the time from the WE rising edge of final address cycle to the WE rising edge of first data cycle.

勝特力材料 886-3-5753170  
 勝特力电子(上海) 86-21-54151736  
 勝特力电子(深圳) 86-755-83298787  
[Http://www.100y.com.tw](http://www.100y.com.tw)

Page Program Operation with Random Data Input

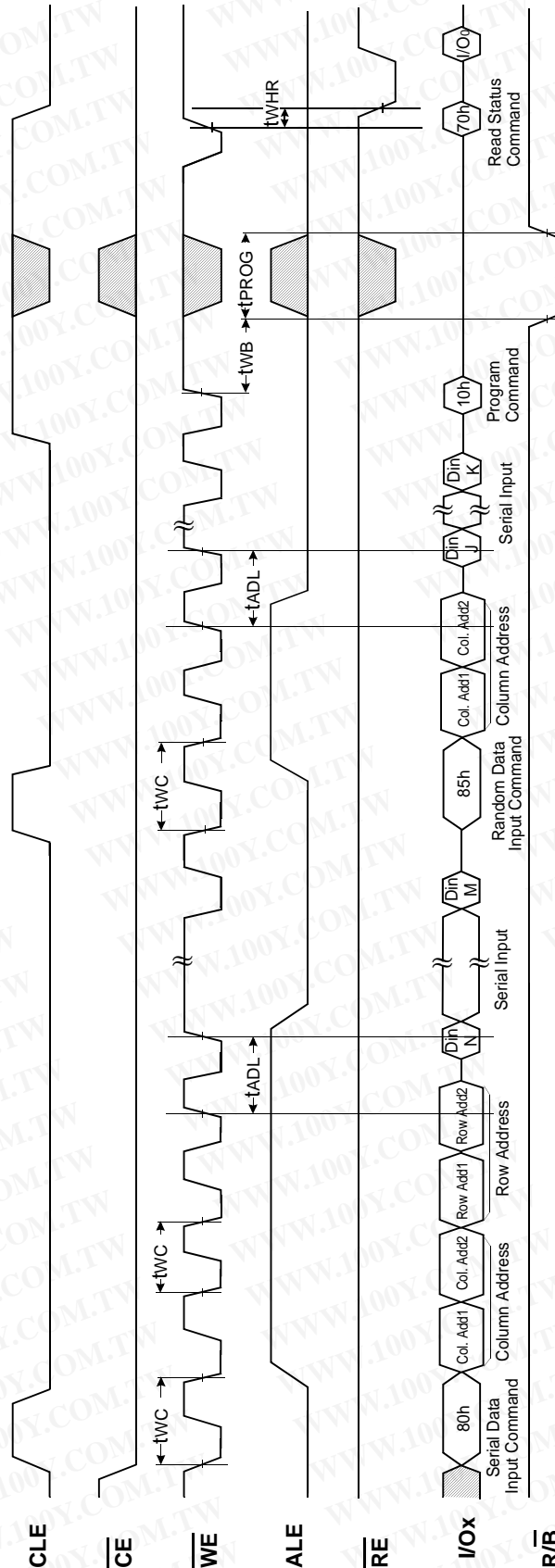

NOTES : 1.  $t_{ADL}$  is the time from the  $\overline{WE}$  rising edge of final address cycle to the  $\overline{WE}$  rising edge of first data cycle.  
 2. For EDC operation, only one time random data input is possible at the same address.

Copy-Back Program Operation with Random Data Input

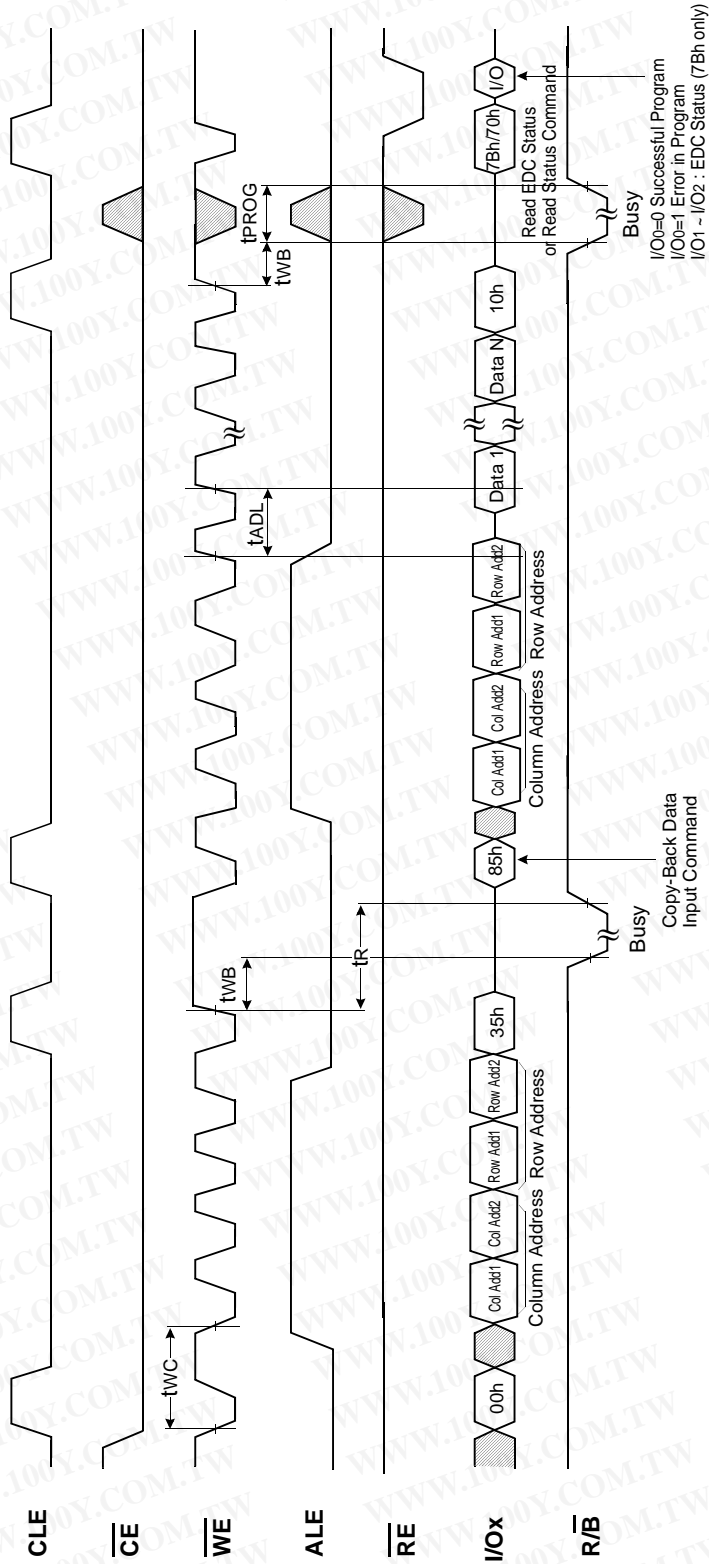

**NOTES :** 1. tADL is the time from the WE rising edge of final address cycle to the WE rising edge of first data cycle.  
 2. For EDC operation, only one time random data input is possible at the same address.

Block Erase Operation

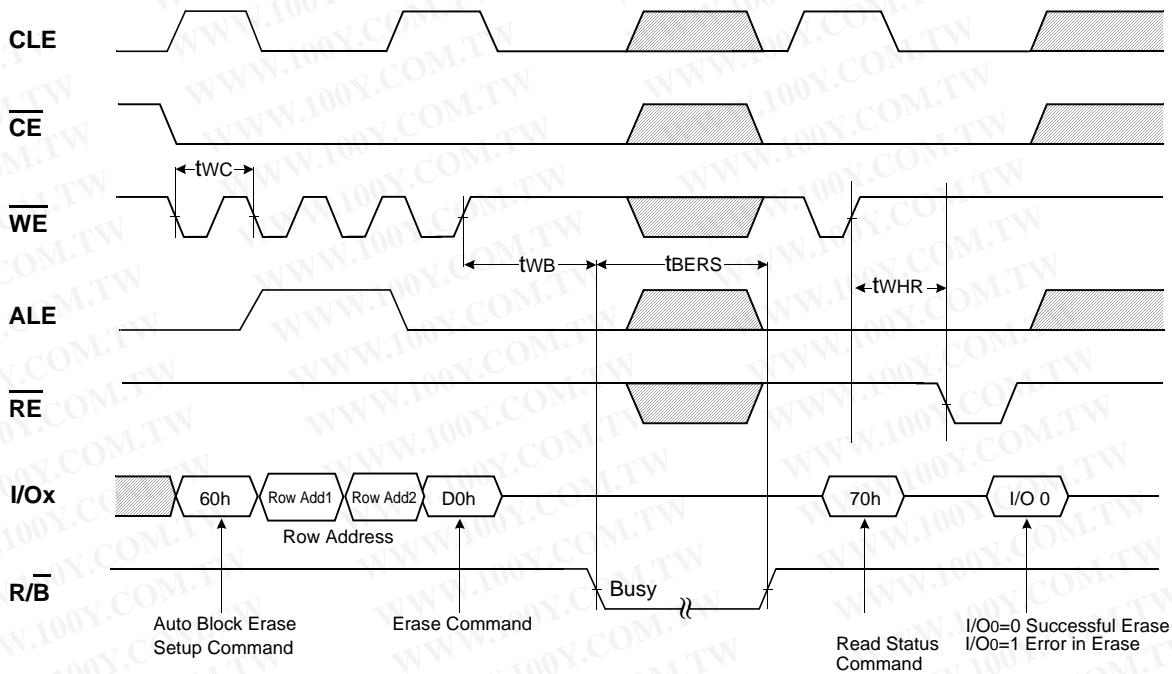

勝特力材料 886-3-5753170  
 勝特力电子(上海) 86-21-54151736  
 勝特力电子(深圳) 86-755-83298787  
[Http://www.100y.com.tw](http://www.100y.com.tw)

Read ID Operation

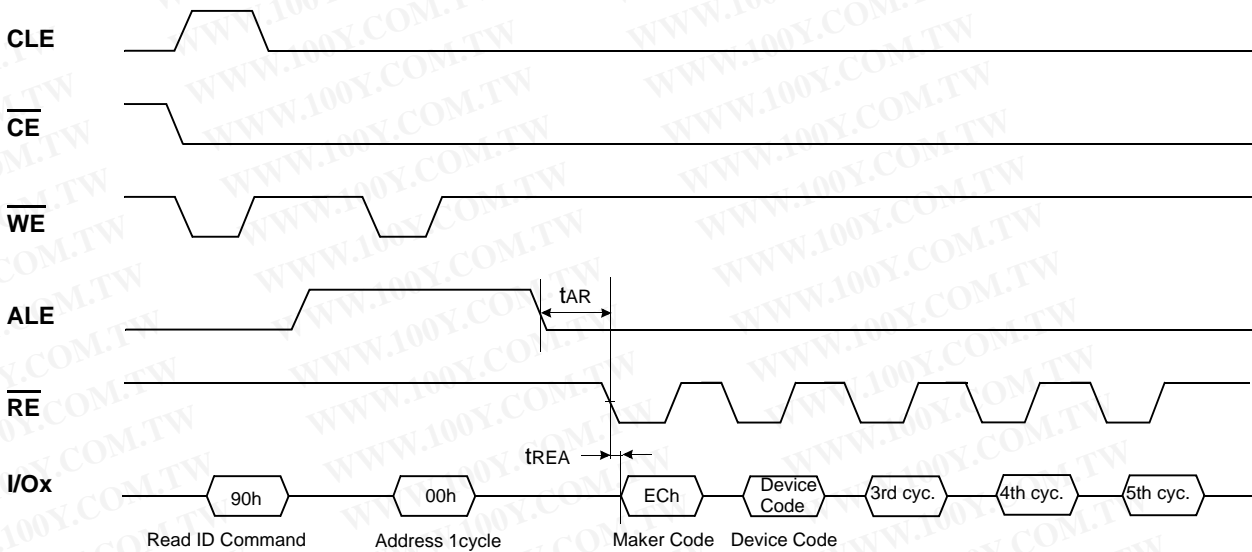

Device	Device Code (2nd Cycle)	3rd Cycle	4th Cycle	5th Cycle
K9F1G08U0B	F1h	00h	95h	40h

勝特力材料 886-3-5753170  
 勝特力电子(上海) 86-21-54151736  
 勝特力电子(深圳) 86-755-83298787  
[Http://www.100y.com.tw](http://www.100y.com.tw)

勝特力材料 886-3-5753170  
 勝特力电子(上海) 86-21-54151736  
 勝特力电子(深圳) 86-755-83298787  
[Http://www.100y.com.tw](http://www.100y.com.tw)

## ID Definition Table

90 ID : Access command = 90H

	Description
1 <sup>st</sup> Byte	Maker Code
2 <sup>nd</sup> Byte	Device Code
3 <sup>rd</sup> Byte	Internal Chip Number, Cell Type, Number of Simultaneously Programmed Pages, Etc
4 <sup>th</sup> Byte	Page Size, Block Size, Redundant Area Size, Organization, Serial Access Minimum
5 <sup>th</sup> Byte	Plane Number, Plane Size

## 3rd ID Data

	Description	I/O7	I/O6	I/O5	I/O4	I/O3	I/O2	I/O1	I/O0
Internal Chip Number	1							0	0
	2							0	1
	4							1	0
	8							1	1
Cell Type	2 Level Cell					0	0		
	4 Level Cell					0	1		
	8 Level Cell					1	0		
	16 Level Cell					1	1		
Number of Simultaneously Programmed Pages	1			0	0				
	2			0	1				
	4			1	0				
	8			1	1				
Interleave Program Between multiple chips	Not Support		0						
	Support		1						
Cache Program	Not Support	0							
	Support	1							

## 4th ID Data

	Description	I/O7	I/O6	I/O5	I/O4	I/O3	I/O2	I/O1	I/O0
Page Size (w/o redundant area)	1KB							0	0
	2KB							0	1
	4KB							1	0
	8KB							1	1
Block Size (w/o redundant area)	64KB			0	0				
	128KB			0	1				
	256KB			1	0				
	512KB			1	1				
Redundant Area Size ( byte/512byte)	8						0		
	16						1		
Organization	x8		0						
	x16		1						
Serial Access Minimum	50ns/30ns	0				0			
	25ns	1				0			
	Reserved	0				1			
	Reserved	1				1			

## 5th ID Data

	Description	I/O7	I/O6	I/O5	I/O4	I/O3	I/O2	I/O1	I/O0
Plane Number	1					0	0		
	2					0	1		
	4					1	0		
	8					1	1		
Plane Size (w/o redundant Area)	64Mb		0	0	0				
	128Mb		0	0	1				
	256Mb		0	1	0				
	512Mb		0	1	1				
	1Gb		1	0	0				
	2Gb		1	0	1				
	4Gb		1	1	0				
8Gb		1	1	1					
Reserved		0						0	0

勝特力材料 886-3-5753170  
 勝特力电子(上海) 86-21-54151736  
 勝特力电子(深圳) 86-755-83298787  
[Http://www.100y.com.tw](http://www.100y.com.tw)

Device Operation

PAGE READ

Page read is initiated by writing 00h-30h to the command register along with four address cycles. After initial power up, 00h command is latched. Therefore only four address cycles and 30h command initiates that operation after initial power up. The 2,112 bytes of data within the selected page are transferred to the data registers in less than 20 $\mu$ s( $t_R$ ). The system controller can detect the completion of this data transfer( $t_R$ ) by analyzing the output of R/B pin. Once the data in a page is loaded into the data registers, they may be read out in 25ns cycle time by sequentially pulsing RE. The repetitive high to low transitions of the RE clock make the device output the data starting from the selected column address up to the last column address.

The device may output random data in a page instead of the consecutive sequential data by writing random data output command. The column address of next data, which is going to be out, may be changed to the address which follows random data output command. Random data output can be operated multiple times regardless of how many times it is done in a page.

Figure 6. Read Operation

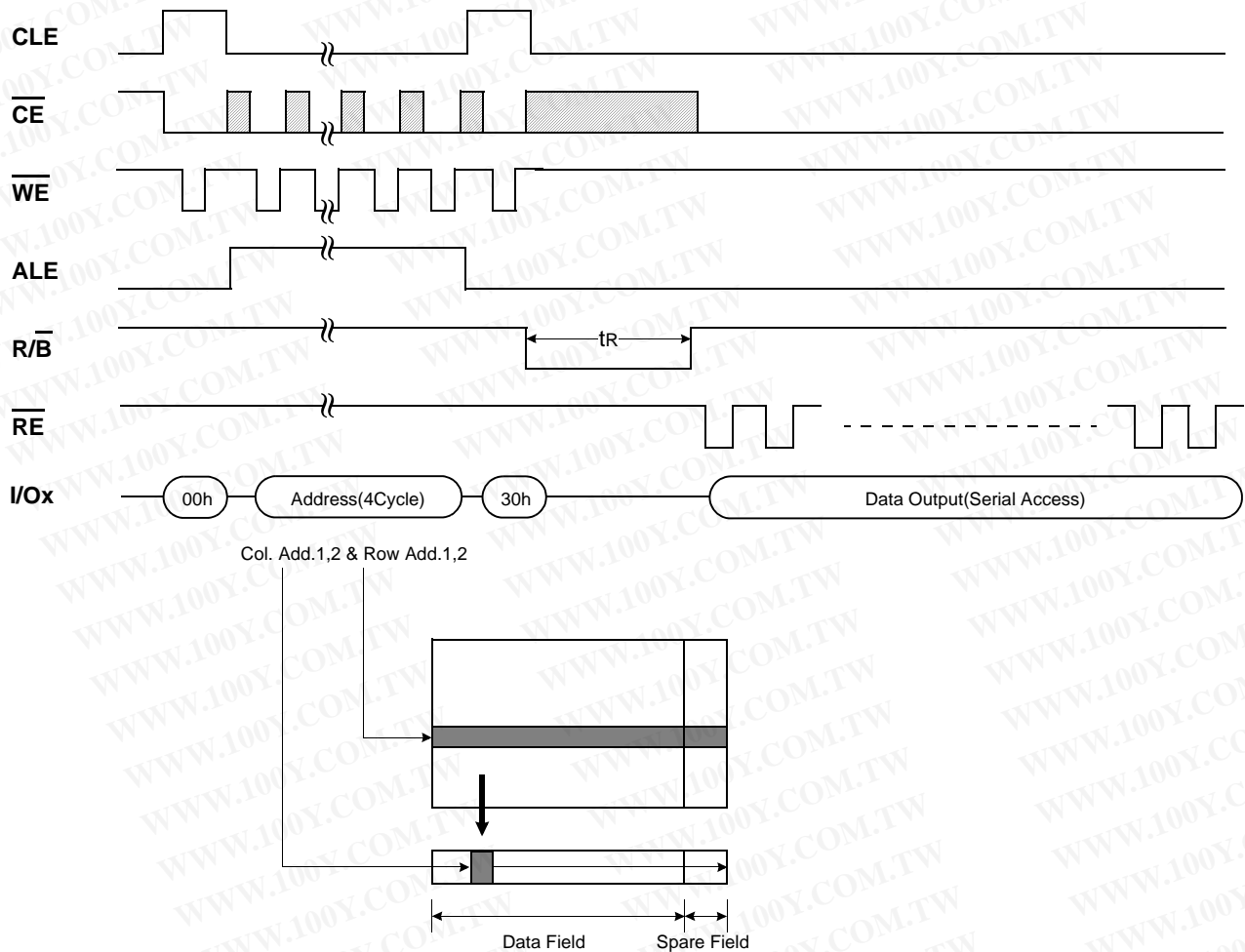

勝特力材料 886-3-5753170  
 勝特力电子(上海) 86-21-54151736  
 勝特力电子(深圳) 86-755-83298787  
[Http://www.100y.com.tw](http://www.100y.com.tw)

勝特力材料 886-3-5753170  
 勝特力电子(上海) 86-21-54151736  
 勝特力电子(深圳) 86-755-83298787  
 Http://www.100y.com.tw

Figure 7. Random Data Output In a Page

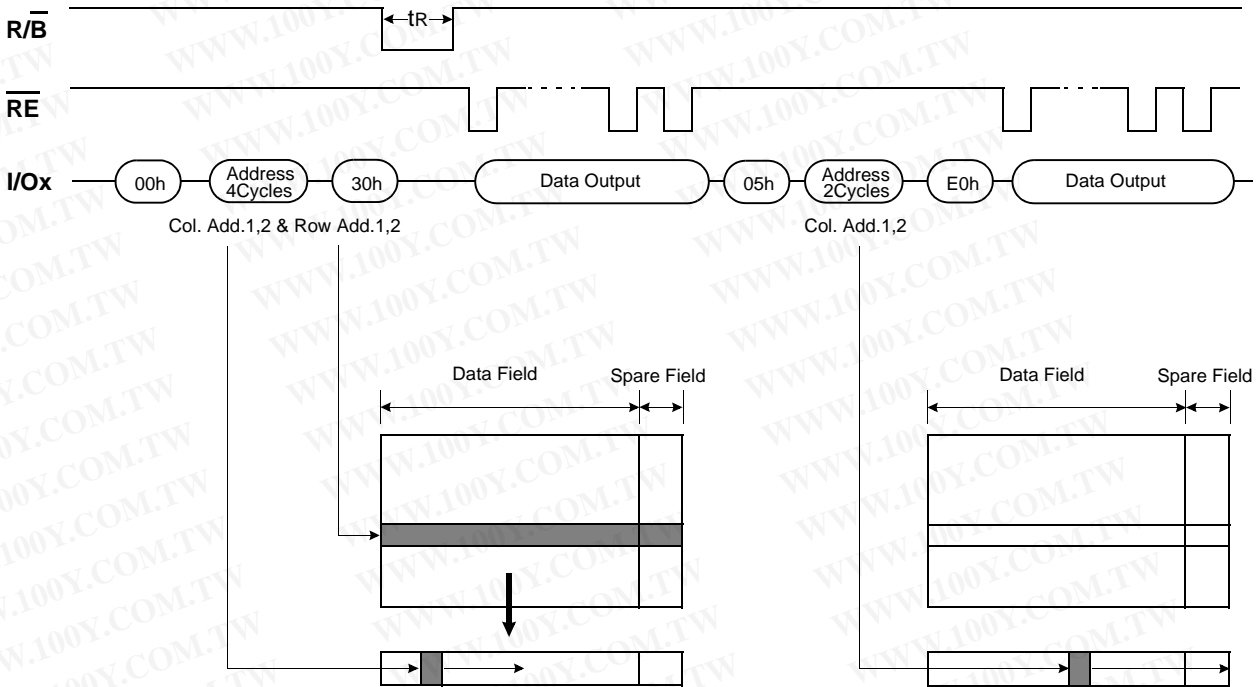

**PAGE PROGRAM**

The device is programmed basically on a page basis, but it does allow multiple partial page programming of a word or consecutive bytes up to 2,112, in a single page program cycle. The number of consecutive partial page programming operation within the same page without an intervening erase operation must not exceed 4 times for a single page. The addressing should be done in sequential order in a block. A page program cycle consists of a serial data loading period in which up to 2,112bytes of data may be loaded into the data register, followed by a non-volatile programming period where the loaded data is programmed into the appropriate cell.

The serial data loading period begins by inputting the Serial Data Input command(80h), followed by the four cycle address inputs and then serial data loading. The words other than those to be programmed do not need to be loaded. The device supports random data input in a page. The column address for the next data, which will be entered, may be changed to the address which follows random data input command(85h). Random data input may be operated multiple times regardless of how many times it is done in a page.

**Modifying the data of a sector by Random Data Input before Copy-Back Program must be performed for the whole sector and is allowed only once per each sector. Any partial modification smaller than a sector corrupts the on-chip EDC codes.**

The Page Program confirm command(10h) initiates the programming process. Writing 10h alone without previously entering the serial data will not initiate the programming process. The internal write state controller automatically executes the algorithms and timings necessary for program and verify, thereby freeing the system controller for other tasks. Once the program process starts, the Read Status Register command may be entered to read the status register. The system controller can detect the completion of a program cycle by monitoring the R/B output, or the Status bit(I/O 6) of the Status Register. Only the Read Status command and Reset command are valid while programming is in progress. When the Page Program is complete, the Write Status Bit(I/O 0) may be checked(Figure 8). The internal write verify detects only errors for "1"s that are not successfully programmed to "0"s. The command register remains in Read Status command mode until another valid command is written to the command register.

Figure 8. Program & Read Status Operation

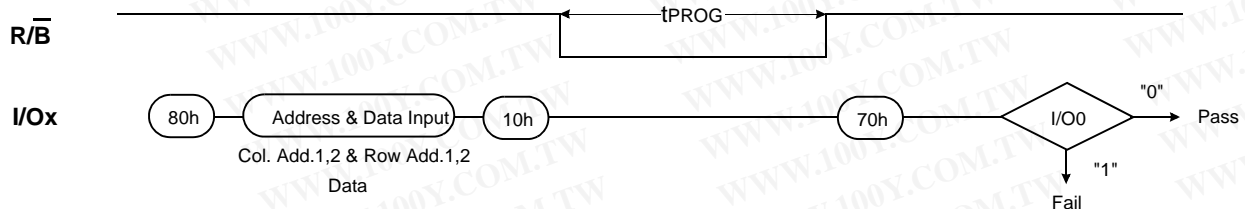
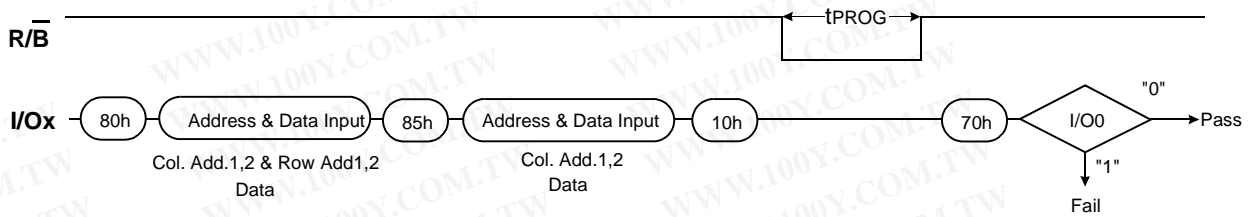

Figure 9. Random Data Input In a Page



Note: 1. For EDC operation, only one time random data input is possible at the same address.

Copy-Back Program

The Copy-Back program is configured to quickly and efficiently rewrite data stored in one page without utilizing an external memory. Since the time-consuming cycles of serial access and re-loading cycles are removed, the system performance is improved. The benefit is especially obvious when a portion of a block is updated and the rest of the block also need to be copied to the newly assigned free block. The operation for performing a copy-back program is a sequential execution of page-read without serial access and copying-program with the address of destination page. A read operation with "35h" command and the address of the source page moves the whole 2,112-byte data into the internal data buffer. As soon as the device returns to Ready state, Page-Copy Data-input command (85h) with the address cycles of destination page followed may be written. The Program Confirm command (10h) is required to actually begin the programming operation. During tPROG, the device executes EDC of itself. Once the program process starts, the Read Status Register command (70h) or Read EDC Status command (7Bh) may be entered to read the status register. The system controller can detect the completion of a program cycle by monitoring the R/B output, or the Status bit(I/O 6) of the Status Register. When the Copy-Back Program is complete, the Write Status Bit(I/O 0) and EDC Status Bits (I/O 1 ~ I/O 2) may be checked(Figure 10 & Figure 11& Figure 12). The internal write verification detects only errors for "1"s that are not successfully programmed to "0"s and the internal EDC checks whether there is only 1-bit error for each 528-byte sector of the source page. More than 2-bit error detection is not available for each 528-byte sector. The command register remains in Read Status command mode or Read EDC Status command mode until another valid command is written to the command register.

During copy-back program, data modification is possible using random data input command (85h) as shown in Figure11. But EDC status bits are not available during copy back for some bits or bytes modified by Random Data Input operation.

However, in case of the 528 byte sector unit modification, EDC status bits are available.

Figure 10. Page Copy-Back Program Operation

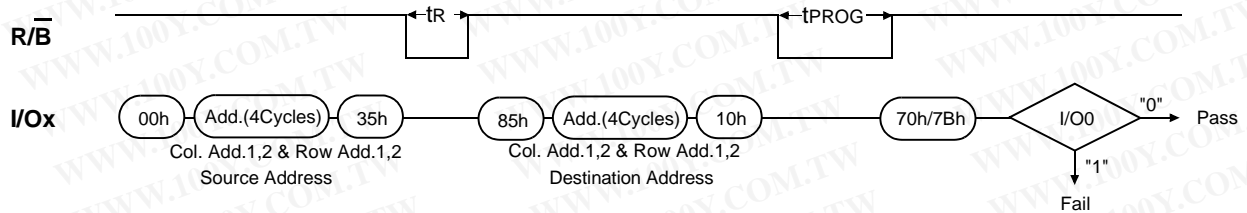

Note: 1. Copy-Back Program operation is allowed only within the same memory plane.  
 2. On the same plane, It's prohibited to operate copy-back program from an odd address page(source page) to an even address page(target page) or from an even address page(source page) to an odd address page(target page). Therefore, the copy-back program is permitted just between odd address pages or even address pages.

Figure 11. Page Copy-Back Program Operation with Random Data Input

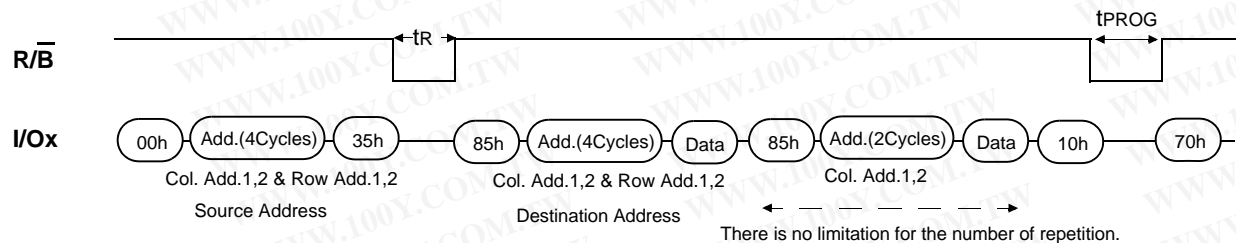

Note: 1. For EDC operation, only one time random data input is possible at the same address.

**EDC OPERATION**

Note that for the user who use Copy-Back with EDC mode, only one time random data input is possible at the same address during Copy-Back program or page program mode. For the user who use Copy-Back without EDC, there is no limitation for the random data input at the same address.

**Figure 12. Page Copy-Back Program Operation with EDC & Read EDC Status**

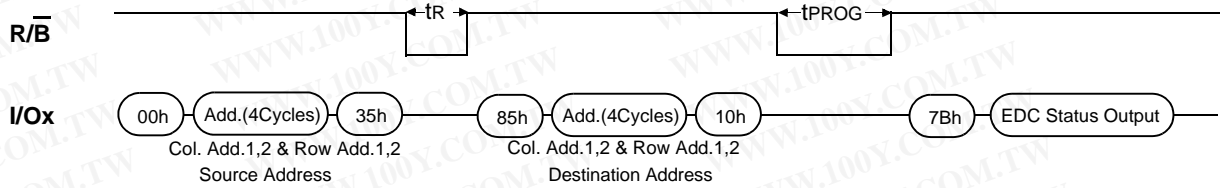

**BLOCK ERASE**

The Erase operation is done on a block basis. Block address loading is accomplished in two cycles initiated by an Erase Setup command(60h). Only address A18 to A27 is valid while A12 to A17 is ignored. The Erase Confirm command(D0h) following the block address loading initiates the internal erasing process. This two-step sequence of setup followed by execution command ensures that memory contents are not accidentally erased due to external noise conditions.

At the rising edge of WE after the erase confirm command input, the internal write controller handles erase and erase-verify. When the erase operation is completed, the Write Status Bit(I/O 0) may be checked. Figure 13 details the sequence.

**Figure 13. Block Erase Operation**

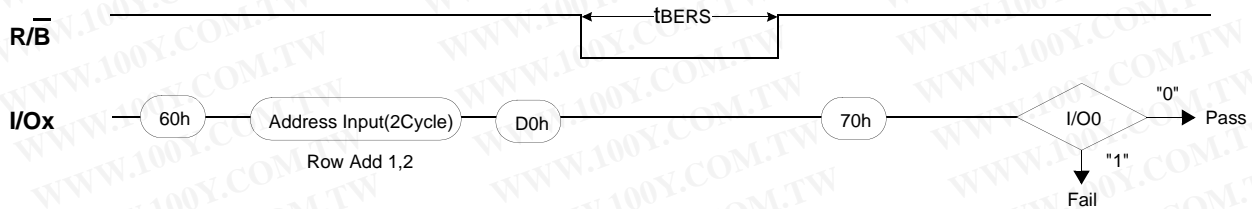

勝特力材料 886-3-5753170  
 勝特力电子(上海) 86-21-54151736  
 勝特力电子(深圳) 86-755-83298787  
[Http://www.100y.com.tw](http://www.100y.com.tw)

## READ STATUS

The device contains a Status Register which may be read to find out whether program or erase operation is completed, and whether the program or erase operation is completed successfully. After writing 70h command to the command register, a read cycle outputs the content of the Status Register to the I/O pins on the falling edge of  $\overline{CE}$  or  $\overline{RE}$ , whichever occurs last. This two line control allows the system to poll the progress of each device in multiple memory connections even when  $\overline{R/\overline{B}}$  pins are common-wired.  $\overline{RE}$  or  $\overline{CE}$  does not need to be toggled for updated status. Refer to Table 3 for specific Status Register definitions. The command register remains in Status Read mode until further commands are issued to it. Therefore, if the status register is read during a random read cycle, the read command(00h) should be given before starting read cycles.

**Table 3. Status Register Definition for 70h Command**

I/O	Page Program	Block Erase	Read	Definition
I/O 0	Pass/Fail	Pass/Fail	Not use	Pass : "0"      Fail : "1"
I/O 1	Not use	Not use	Not use	Don't -cared
I/O 2	Not use	Not use	Not use	Don't -cared
I/O 3	Not Use	Not Use	Not Use	Don't -cared
I/O 4	Not Use	Not Use	Not Use	Don't -cared
I/O 5	Not Use	Not Use	Not Use	Don't -cared
I/O 6	Ready/Busy	Ready/Busy	Ready/Busy	Busy : "0"      Ready : "1"
I/O 7	Write Protect	Write Protect	Write Protect	Protected : "0"      Not Protected : "1"

**NOTE :** 1. I/Os defined 'Not use' are recommended to be masked out when Read Status is being executed.

## READ EDC STATUS

Read EDC status operation is only available on 'Copy Back Program'. The device contains an EDC Status Register which may be read to find out whether there is error during 'Read for Copy Back'. After writing 7Bh command to the command register, a read cycle outputs the content of the EDC Status Register to the I/O pins on the falling edge of  $\overline{CE}$  or  $\overline{RE}$ , whichever occurs last. This two line control allows the system to poll the progress of each device in multiple memory connections even when  $\overline{R/\overline{B}}$  pins are common-wired.  $\overline{RE}$  or  $\overline{CE}$  does not need to be toggled for updated status. Refer to Table 4 for specific Status Register definitions. The command register remains in EDC Status Read mode until further commands are issued to it.

**Table 4. Status Register Definition for 7Bh Command**

I/O	Copy Back Program	Page Program	Block Erase	Read	Definition
I/O 0	Pass/Fail of Copy Back Program	Pass/Fail	Pass/Fail	Not use	Pass : "0", Fail : "1"
I/O 1	EDC Status	Not use	Not use	Not use	No Error : "0", Error : "1"
I/O 2	Validity of EDC Status	Not use	Not use	Not use	Valid : "1", Invalid : "0"
I/O 3	Not Use	Not Use	Not Use	Not Use	Don't -cared
I/O 4	Not Use	Not Use	Not Use	Not Use	Don't -cared
I/O 5	Not Use	Not Use	Not Use	Not Use	Don't -cared
I/O 6	Ready/Busy of Copy Back Program	Ready/Busy	Ready/Busy	Ready/Busy	Busy : "0", Ready : "1"
I/O 7	Write Protect of Copy Back Program	Write Protect	Write Protect	Write Protect	Protected : "0", Not Protected : "1"

**NOTE :** 1. I/Os defined 'Not use' are recommended to be masked out when Read Status is being executed.

2. More than 2-bit error detection isn't available for each 528 Byte sector.

That is to say, only 1-bit error detection is available for each 528 Byte sector.

勝特力材料 886-3-5753170  
 勝特力电子(上海) 86-21-54151736  
 勝特力电子(深圳) 86-755-83298787  
[Http://www.100y.com.tw](http://www.100y.com.tw)

**Read ID**

The device contains a product identification mode, initiated by writing 90h to the command register, followed by an address input of 00h. Five read cycles sequentially output the manufacturer code(ECh), and the device code and 3rd, 4th, 5th cycle ID respectively. The command register remains in Read ID mode until further commands are issued to it. Figure 18 shows the operation sequence.

**Figure 18. Read ID Operation**

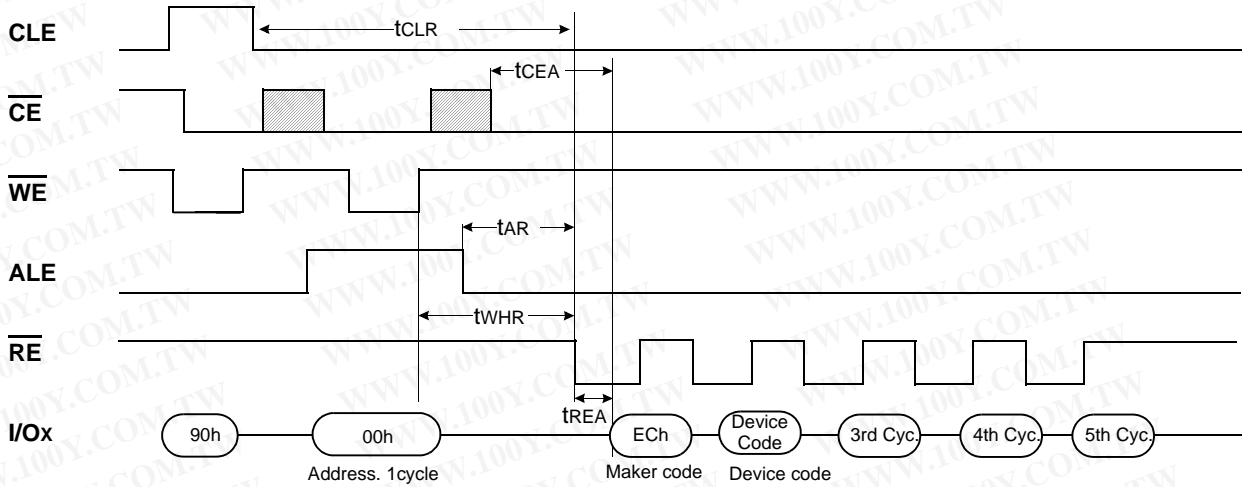

Device	Device Code (2nd Cycle)	3rd Cycle	4th Cycle	5th Cycle
K9F1G08U0B	F1h	00h	95h	40h

**RESET**

The device offers a reset feature, executed by writing FFh to the command register. When the device is in Busy state during random read, program or erase mode, the reset operation will abort these operations. The contents of memory cells being altered are no longer valid, as the data will be partially programmed or erased. The command register is cleared to wait for the next command, and the Status Register is cleared to value C0h when  $\overline{WP}$  is high. If the device is already in reset state a new reset command will be accepted by the command register. The  $\overline{R/B}$  pin changes to low for tRST after the Reset command is written. Refer to Figure 19 below.

**Figure 19. RESET Operation**

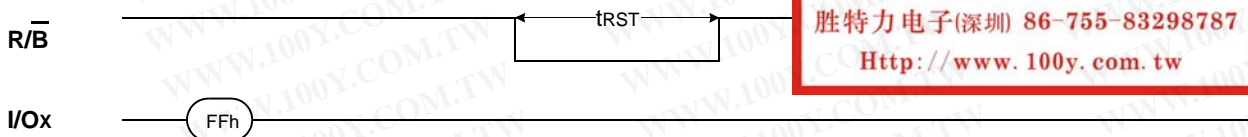

勝特力材料 886-3-5753170  
 勝特力电子(上海) 86-21-54151736  
 勝特力电子(深圳) 86-755-83298787  
[Http://www.100y.com.tw](http://www.100y.com.tw)

**Table 5. Device Status**

	After Power-up	After Reset
Operation mode	00h Command is latched	Waiting for next command

READY/BUSY

The device has a  $\overline{R/B}$  output that provides a hardware method of indicating the completion of a page program, erase and random read completion. The  $\overline{R/B}$  pin is normally high but transitions to low after program or erase command is written to the command register or random read is started after address loading. It returns to high when the internal controller has finished the operation. The pin is an open-drain driver thereby allowing two or more  $\overline{R/B}$  outputs to be Or-tied. Because pull-up resistor value is related to  $t_r(\overline{R/B})$  and current drain during busy( $i_{busy}$ ), an appropriate value can be obtained with the following reference chart(Fig.20). Its value can be determined by the following guidance.

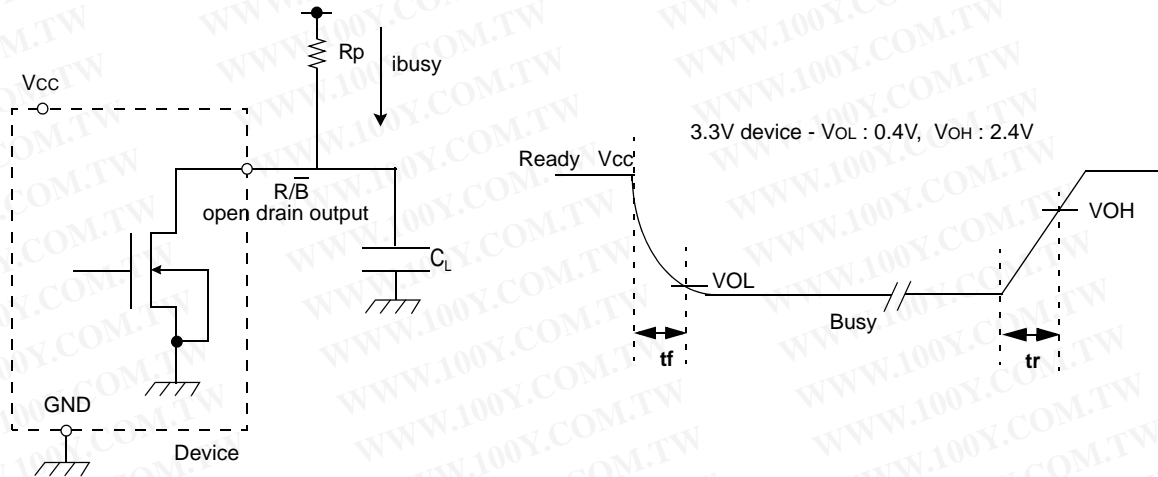
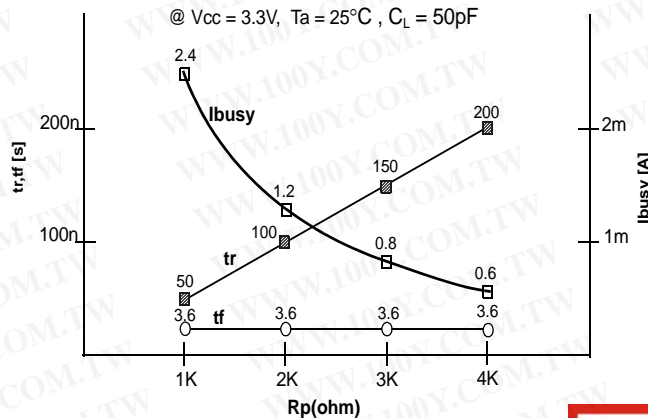

Figure 20. Rp vs tr,tf & Rp vs ibusy



Rp value guidance

$$R_{p(\min, 3.3V \text{ part})} = \frac{V_{CC(\text{Max.})} - V_{OL(\text{Max.})}}{I_{OL} + \sum I_L} = \frac{3.2V}{8mA + \sum I_L}$$

where  $I_L$  is the sum of the input currents of all devices tied to the  $\overline{R/B}$  pin.

$R_{p(\max)}$  is determined by maximum permissible limit of  $t_r$

勝特力材料 886-3-5753170  
 勝特力电子(上海) 86-21-54151736  
 勝特力电子(深圳) 86-755-83298787  
[Http://www.100y.com.tw](http://www.100y.com.tw)

### Data Protection & Power up sequence

The device is designed to offer protection from any involuntary program/erase during power-transitions. An internal voltage detector disables all functions whenever  $V_{CC}$  is below about 2V.  $\overline{WP}$  pin provides hardware protection and is recommended to be kept at  $V_{IL}$  during power-up and power-down. A recovery time of minimum 100 $\mu$ s is required before internal circuit gets ready for any command sequences as shown in Figure 21. The two step command sequence for program/erase provides additional software protection.

Figure 21. AC Waveforms for Power Transition

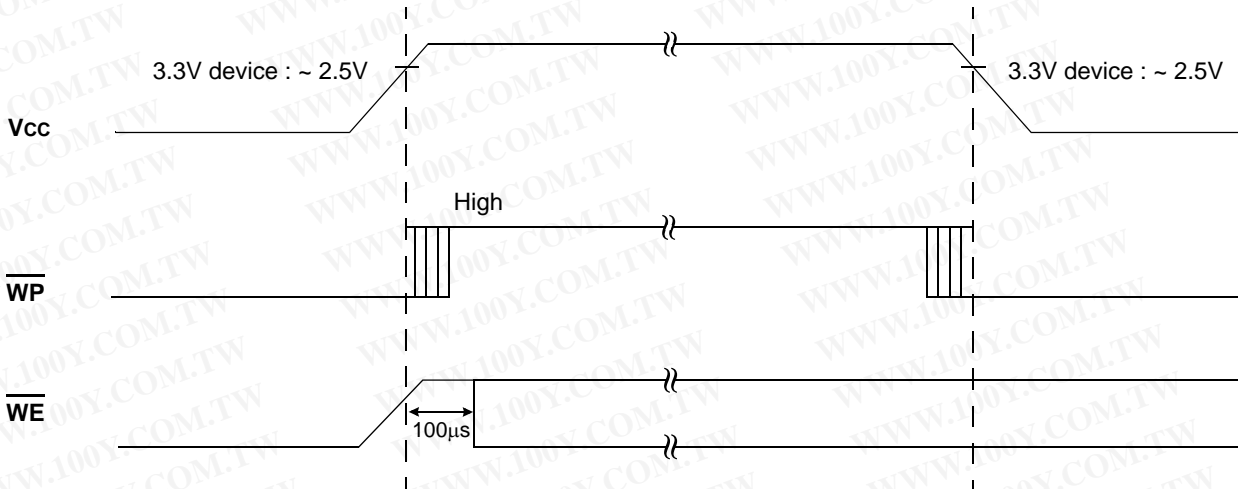

勝特力材料 886-3-5753170  
 勝特力电子(上海) 86-21-54151736  
 勝特力电子(深圳) 86-755-83298787  
[Http://www.100y.com.tw](http://www.100y.com.tw)