

# Si photodiode S1226 series

For UV to visible, precision photometry; suppressed IR sensitivity

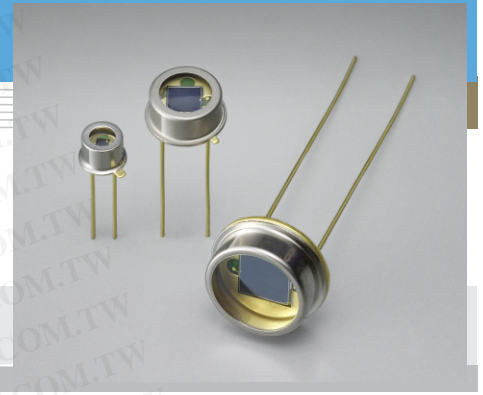

### Features

- High UV sensitivity: QE 75 % ( $\lambda=200$  nm)
- Suppressed IR sensitivity
- Low dark current
- High reliability

### Applications

- Analytical equipment
- Optical measurement equipment, etc.

### General ratings / absolute maximum ratings

| Type No.   | Dimensional outline/<br>Window material * | Package<br>(mm) | Active area size<br>(mm) | Effective active area<br>(mm <sup>2</sup> ) | Absolute maximum ratings                      |   |   |
|------------|---|-----------------|--------------------------|---|---|---|---|
|            |   |                 |                          |   | Reverse voltage<br>V <sub>R</sub> Max.<br>(V) | Operating temperature<br>T <sub>opr</sub><br>(°C) | Storage temperature<br>T <sub>stg</sub><br>(°C) |
| S1226-18BQ | ①/Q                                       | TO-18           | 1.1 × 1.1                | 1.2   | 5   | -20 to +60  | -55 to +80                                      |
| S1226-18BK | ①/K                                       |                 |                          |   |   | -40 to +100                                       | -55 to +125                                     |
| S1226-5BQ  | ②/Q                                       | TO-5            | 2.4 × 2.4                | 5.7   |   | -20 to +60  | -55 to +80                                      |
| S1226-5BK  | ②/K                                       |                 |                          |   |   | -40 to +100                                       | -55 to +125                                     |
| S1226-44BQ | ②/Q                                       |                 |                          |   |   | -20 to +60  | -55 to +80                                      |
| S1226-44BK | ②/K                                       | -40 to +100     | -55 to +125              |   |   |   |   |
| S1226-8BQ  | ③/Q                                       | TO-8            | 5.8 × 5.8                | 33  |   | -20 to +60  | -55 to +80                                      |
| S1226-8BK  | ③/K                                       |                 |                          |   |   | -40 to +100                                       | -55 to +125                                     |

### Electrical and optical characteristics (Typ. T<sub>a</sub>=25 °C, unless otherwise noted)

| Type No.   | Spectral response range<br>$\lambda$<br>(nm) | Peak sensitivity wavelength<br>$\lambda_p$<br>(nm) | Photo sensitivity S (A/W) |        |      | Short circuit current I <sub>sc</sub> 100 lx |           | Dark current I <sub>D</sub> V <sub>R</sub> =10 mV Max. (pA) | Temp. coefficient of I <sub>D</sub> T <sub>CID</sub> (times/°C) | Rise time t <sub>r</sub> V <sub>R</sub> =0 V R <sub>L</sub> =1 k $\Omega$ (μs) | Terminal capacitance C <sub>t</sub> V <sub>R</sub> =0 V f=10 kHz (pF) | Shunt resistance R <sub>sh</sub> V <sub>R</sub> =10 mV |                    | NEP (W/Hz <sup>1/2</sup> ) |                         |
|------------|--|--|---------------------------|--------|------|--|-----------|---|---|--|---|--|--------------------|----------------------------|-------------------------|
|            |  |  | $\lambda_p$               | 200 nm |      | He-Ne laser 633 nm                           | Min. (μA) |   |   |  |   | Typ. (μA)  | Min. (G $\Omega$ ) |                            | Typ. (G $\Omega$ )      |
|            |  |  |                           | Min.   | Typ. |  |           |   |   |  |   |  |                    |                            |                         |
| S1226-18BQ | 190 to 1000                                  | 720  | 0.36                      | 0.10   | 0.12 | 0.34   | 0.5       | 0.66  | 2   | 1.12   | 0.15  | 35   | 5                  | 50                         | 1.6 × 10 <sup>-15</sup> |
| S1226-18BK | 320 to 1000                                  |  |                           | -      | -    |  |           |   |   |  |   |  |                    |                            |                         |
| S1226-5BQ  | 190 to 1000                                  |  |                           | 0.10   | 0.12 |  |           |   |   |  |   |  |                    |                            |                         |
| S1226-5BK  | 320 to 1000                                  |  |                           | -      | -    |  |           |   |   |  |   |  |                    |                            |                         |
| S1226-44BQ | 190 to 1000                                  |  |                           | 0.10   | 0.12 |  |           |   |   |  |   |  |                    |                            |                         |
| S1226-44BK | 320 to 1000                                  |  |                           | -      | -    |  |           |   |   |  |   |  |                    |                            |                         |
| S1226-8BQ  | 190 to 1000                                  |  |                           | 0.10   | 0.12 |  |           |   |   |  |   |  |                    |                            |                         |
| S1226-8BK  | 320 to 1000                                  |  |                           | -      | -    |  |           |   |   |  |   |  |                    |                            |                         |

\* Window material, K: borosilicate glass, Q: quartz glass

勝特力材料 886-3-5753170  
 勝特力电子(上海) 86-21-54151736  
 勝特力电子(深圳) 86-755-83298787  
[Http://www.100y.com.tw](http://www.100y.com.tw)

■ Spectral response

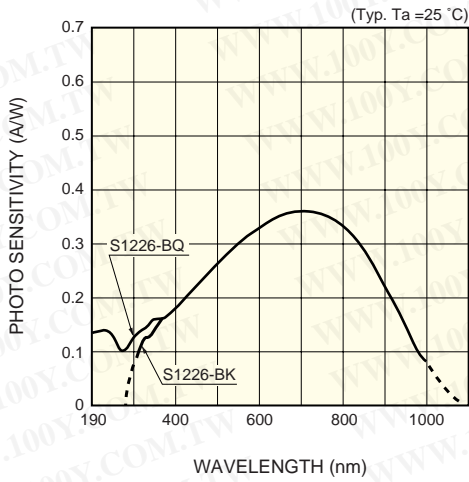

■ Photo sensitivity temperature characteristic

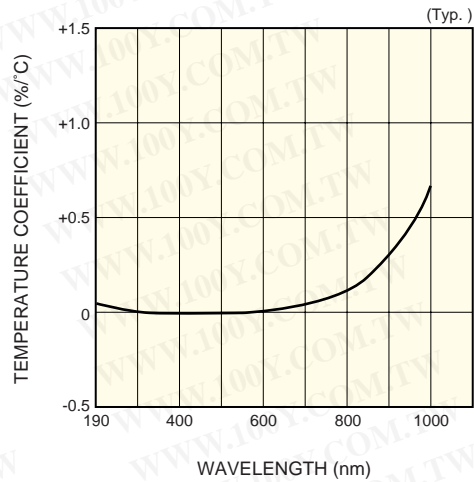

■ Rise time vs. load resistance

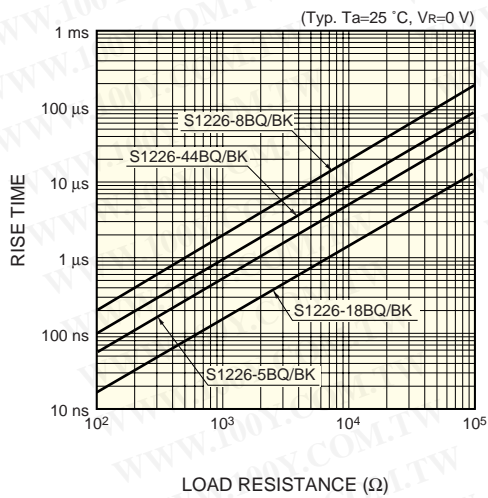

■ Dark current vs. reverse voltage

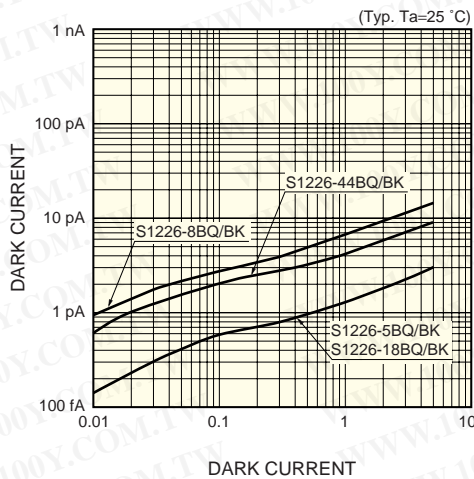

■ Shunt resistance vs. ambient temperature

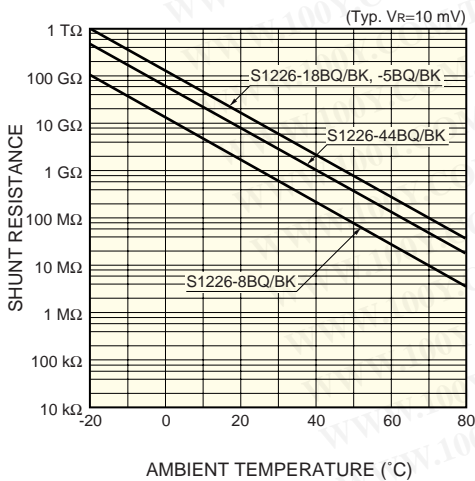

勝特力材料 886-3-5753170  
 勝特力电子(上海) 86-21-54151736  
 勝特力电子(深圳) 86-755-83298787  
[Http://www.100y.com.tw](http://www.100y.com.tw)

■ Dimensional outlines (unit: mm)

① S1226-18BQ/-18BK

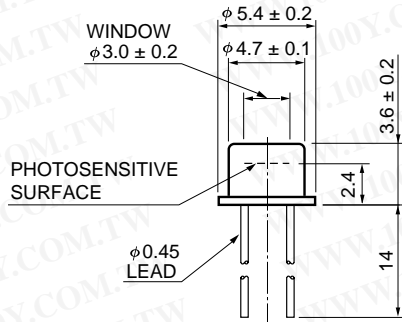

CONNECTED TO CASE

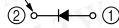

KSPDA0113EB

② S1226-5BQ/K, S1226-44BQ/K

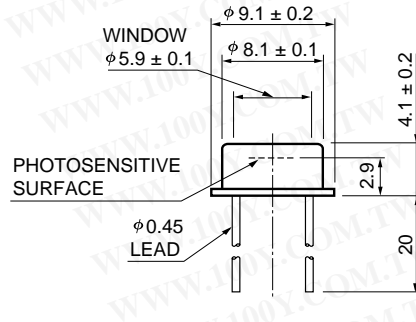

CONNECTED TO CASE



The K type borosilicate glass window may extend a maximum of 0.2 mm above the upper surface of the cap.

KSPDA0114EA

③ S1226-8BQ/-8BK

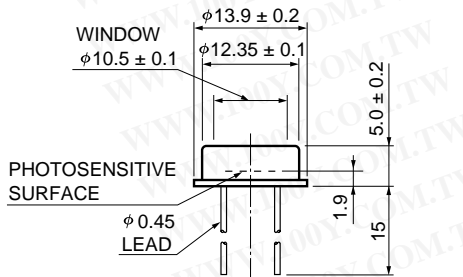

CONNECTED TO CASE



The K type borosilicate glass window may extend a maximum of 0.2 mm above the upper surface of the cap.

KSPDA0115EA