

DATA SHEET

LOW OHMIC CHIP RESISTORS

RL series (Pb Free)

5%, 1%

sizes 0402/0603/0805/1206/
1210/1218/2010/2512

勝特力材料 886-3-5753170
勝特力电子(上海) 86-21-54151736
勝特力电子(深圳) 86-755-83298787
[Http://www.100y.com.tw](http://www.100y.com.tw)



SCOPE

This specification describes RL0402 to RL2512 low ohmic chip resistors with lead-free terminations made by thick film process.

ORDERING INFORMATION

Part number is identified by the series, size, tolerance, packing type, temperature coefficient, taping reel and resistance value.

YAGEO ORDERING CODE

CTC CODE

RL XXXX X X X XX XXXX L
 (1) (2) (3) (4) (5) (6) (7)

ORDERING EXAMPLE

The ordering code of a RL0805 chip resistor, value 0.56 Ω with ±1% tolerance, supplied in 7-inch tape reel is: RL0805FR-070R56L.

(1) SIZE

- 0402
- 0603
- 0805
- 1206
- 1210
- 1218
- 2010
- 2512

NOTE

1. The "L" at the end of the code is only for ordering. On the reel label, the standard CTC will be mentioned an additional stamp "LFP"= lead free production.
2. Products with lead in terminations fulfil the same requirements as mentioned in this datasheet.
3. Products with lead in terminations will be phased out in the coming months (before July 1st, 2006)

(2) TOLERANCE

- F = ±1%
- J = ±5%

(3) PACKAGING TYPE

- R = Paper/PE taping reel
- K = Embossed taping reel

(4) TEMPERATURE COEFFICIENT OF RESISTANCE

- = Base on spec

(5) TAPING REEL

- 07 = 7 inch dia. Reel

(6) RESISTANCE VALUE

- 0R01, 0R056, 0R56, 0R91 of E24 series (E48/96 on request).

(7) RESISTOR TERMINATIONS

- L = Lead free terminations (matte tin)

勝特力材料 886-3-5753170
勝特力电子(上海) 86-21-54151736
勝特力电子(深圳) 86-755-83298787
[Http://www.100y.com.tw](http://www.100y.com.tw)

MARKING

RL0805 / RL1206 / RL1210 / RL1218 / RL2010 / RL2512



E-24 series: 4 digits

The “R” is used as a decimal point; the other 3 digits are significant.

RL0603: $R \geq 100 \text{ m}\Omega$ IN E-24 SERIES, $R = 10/20/30/40/50/60 \text{ m}\Omega$



3 digits

The “R” is used as a decimal point; the other 2 digits are significant.

RL0402 / SPECIALITY / RL0603: $R < 100 \text{ m}\Omega$ EXCEPT 10/20/30/40/50/60 mΩ

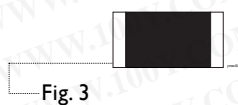

No marking

勝特力材料 886-3-5753170
勝特力电子(上海) 86-21-54151736
勝特力电子(深圳) 86-755-83298787
[Http://www.100y.com.tw](http://www.100y.com.tw)

For marking codes, please see EIA-marking code rules in data sheet “Chip resistors marking”.

CONSTRUCTION

The resistors are constructed out of a high-grade ceramic body. Internal metal electrodes are added at each end and connected by a resistive paste. The composition of the paste is adjusted to give the approximate required resistance and laser cutting of this resistive layer that achieves tolerance trims the value. The resistive layer is covered with a protective coat and printed with the resistance value. Finally, the two external terminations (matte tin) are added. See fig. 4.

OUTLINES

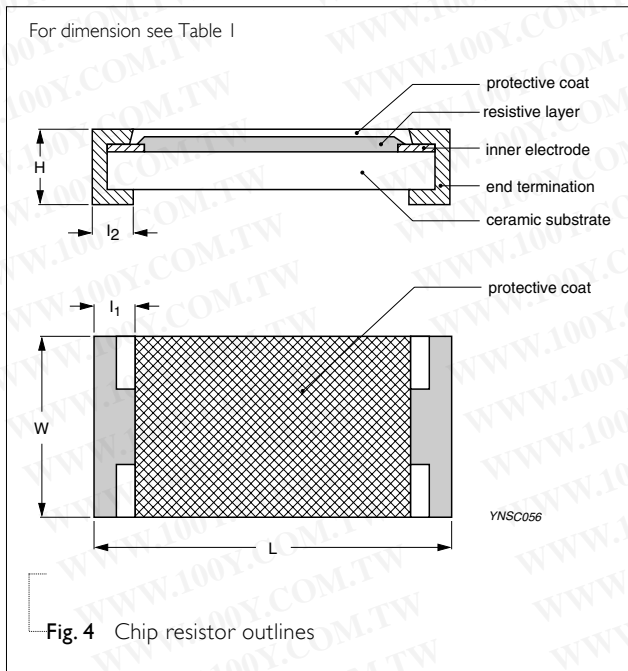

CONSTRUCTION

Table I For outlines see fig. 4

TYPE	L (mm)	W (mm)	H (mm)	l ₁ (mm)	l ₂ (mm)
RL0402	1.00 ±0.10	0.50 ±0.05	0.35 ±0.05	0.20 ±0.10	0.25 ±0.10
RL0603	1.60 ±0.10	0.80 ±0.10	0.45 ±0.10	0.25 ±0.15	0.25 ±0.15
RL0805	2.00 ±0.10	1.25 ±0.10	0.50 ±0.10	0.35 ±0.20	0.35 ±0.20
RL1206	3.10 ±0.10	1.60 ±0.10	0.55 ±0.10	0.45 ±0.20	0.40 ±0.20
RL1210	3.10 ±0.10	2.60 ±0.15	0.55 ±0.10	0.50 ±0.20	0.50 ±0.20
RL1218	3.05 ±0.15	4.60 ±0.20	0.55 ±0.10	0.45 ±0.25	0.50 ±0.25
RL2010	5.00 ±0.10	2.50 ±0.15	0.55 ±0.10	0.60 ±0.20	0.50 ±0.20
RL2512	6.35 ±0.10	3.20 ±0.15	0.55 ±0.10	0.60 ±0.20	0.50 ±0.20

ELECTRICAL CHARACTERISTICS

Table 2

TYPE / RESISTANCE RANGE	TEMPERATURE COEFFICIENT OF RESISTANCE					
RL0402 100mΩ≤R<1Ω	100mΩ≤R<1Ω ±800 ppm/°C					
RL0603 10mΩ≤R<1Ω	10mΩ≤R≤36mΩ	36mΩ<R≤91mΩ	91mΩ<R≤500mΩ		500mΩ<R<1Ω	
	±1,500 ppm/°C	±1,200 ppm/°C	±800 ppm/°C		±300 ppm/°C	
RL0805	10mΩ≤R≤18mΩ	18mΩ<R≤47mΩ	47mΩ<R≤91mΩ	91mΩ<R≤360mΩ	360mΩ<R≤500mΩ	500mΩ<R<1Ω
	±1,500 ppm/°C	±1,200 ppm/°C	±1,000 ppm/°C	±600 ppm/°C	±300 ppm/°C	±200 ppm/°C
RL1206	±1,500 ppm/°C	±1,200 ppm/°C	±1,000 ppm/°C	±600 ppm/°C	±300 ppm/°C	±200 ppm/°C
RL1210	±1,500 ppm/°C	±1,000 ppm/°C	±800 ppm/°C	±600 ppm/°C	±300 ppm/°C	±200 ppm/°C
RL2010	±1,500 ppm/°C	±1,200 ppm/°C	±1,000 ppm/°C	±600 ppm/°C	±300 ppm/°C	±200 ppm/°C
RL2512	±1,500 ppm/°C	±1,200 ppm/°C	±800 ppm/°C	±600 ppm/°C	±300 ppm/°C	±200 ppm/°C
RL1218 10mΩ≤R<1Ω	10mΩ≤R≤30mΩ	30mΩ<R≤56mΩ	56mΩ<R≤180mΩ	180mΩ<R<1Ω		
	±2,000 ppm/°C	±1,000 ppm/°C	±700 ppm/°C	±250 ppm/°C		

FOOTPRINT AND SOLDERING PROFILES

For recommended footprint and soldering profiles, please see the special data sheet “Chip resistors mounting”.

ENVIRONMENTAL DATA

For material declaration information (IMDS-data) of the products, please see the separated info “Environmental data”.

PACKING STYLE AND PACKAGING QUANTITY

Table 3 Packing style and packaging quantity

PACKING STYLE	REEL DIMENSION	RL0402	RL0603	RL0805	RL1206	RL1210	RL1218	RL2010	RL2512
Paper/PE taping reel (R)	7" (178 mm)	10,000	5,000	5,000	5,000	5,000	---	---	---
Embossed taping reel (K)	7" (178 mm)	---	---	---	---	---	4,000	4,000	4,000

NOTE

1. For Paper/PE/Embossed tape and reel specification/dimensions, please see the special data sheet “Packing” document.

勝特力材料 886-3-5753170
勝特力电子(上海) 86-21-54151736
勝特力电子(深圳) 86-755-83298787
[Http://www.100y.com.tw](http://www.100y.com.tw)

FUNCTIONAL DESCRIPTION

OPERATING TEMPERATURE RANGE

Range: -55°C to +125°C

POWER RATING

Each type rated power at 70°C:
 RL0402=1/16 W; RL0603=1/10 W; RL0805=1/8 W;
 RL1206=1/4 W; RL1210=1/2 W; RL1218=1 W;
 RL2010=3/4 W; RL2512=1 W.

RATED VOLTAGE

The DC or AC (rms) continuous working voltage corresponding to the rated power is determined by the following formula:

$$V = \sqrt{P \times R}$$

Where

V = Continuous rated DC or AC (rms) working voltage (V)

P = Rated power (W)

R = Resistance value (Ω)

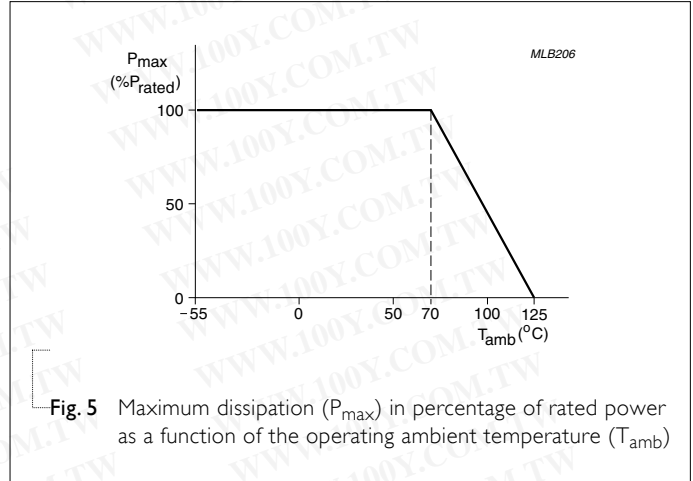

Fig. 5 Maximum dissipation (P_{max}) in percentage of rated power as a function of the operating ambient temperature (T_{amb})

勝特力材料 886-3-5753170
 勝特力电子(上海) 86-21-54151736
 勝特力电子(深圳) 86-755-83298787
[Http://www.100y.com.tw](http://www.100y.com.tw)

TESTS AND REQUIREMENTS

Table 4 Test condition, procedure and requirements

TEST	TEST METHOD	PROCEDURE	REQUIREMENTS
Temperature Coefficient of Resistance (T.C.R.)	MIL-STD-202F-method 304;	At +25/-55 °C and +25/+125 °C	Refer to table 2
	JIS C 5202-4.8	<p>Formula:</p> $T.C.R = \frac{R_2 - R_1}{R_1(t_2 - t_1)} \times 10^6 \text{ (ppm/°C)}$ <p>Where $t_1 = +25 \text{ °C}$ or specified room temperature $t_2 = -55 \text{ °C}$ or +125 °C test temperature $R_1 =$resistance at reference temperature in ohms $R_2 =$resistance at test temperature in ohms</p>	
Thermal Shock	MIL-STD-202F-method I07G; IEC 60115-1 4.19	At -65 (+0/-10) °C for 2 minutes and at +125 (+10/-0) °C for 2 minutes; 25 cycles	±1.0%
Low Temperature Operation	MIL-R-55342D-Para 4.7.4	At -65 (+0/-5) °C for 1 hour; RCWV applied for 45 (+5/-0) minutes	±1.0% No visible damage
Short Time Overload	MIL-R-55342D-Para 4.7.5; IEC 60115-1 4.13	2.5 × RCWV applied for 5 seconds at room temperature	±1.0% for 1% tol. ±2.0% for 5% tol. No visible damage
Insulation Resistance	MIL-STD-202F-method 302; IEC 60115-1 4.6.1.1	One DC voltage (V) applied for 1 minute Details see below table 5	≥10 GΩ
Dielectric Withstand Voltage	MIL-STD-202F-method 301; IEC 60115-1 4.6.1.1	One AC voltage (V _{rms}) applied for 1 minute Details see below table 5	No breakdown or flashover
Resistance to Soldering Heat	MIL-STD-202F-method 210C; IEC 60115-1 4.18	Unmounted chips; 260 ±5 °C for 10 ±1 seconds	±1.0% No visible damage
Life	MIL-STD-202F-method I08A; IEC 60115-1 4.25.1	At 70±2 °C for 1,000 hours; RCWV applied for 1.5 hours on and 0.5 hour off	±2% for 1% tol. ±3% for 5% tol.

勝特力材料 886-3-5753170
勝特力电子(上海) 86-21-54151736
勝特力电子(深圳) 86-755-83298787
Http://www.100y.com.tw

Table 4 Test condition, procedure and requirements (continued)

TEST	TEST METHOD	PROCEDURE	REQUIREMENTS
Solderability	MIL-STD-202F-method 208A;	Solder bath at 245±3 °C	Well tinned (≥95% covered)
	IEC 60115-1 4.17	Dipping time: 2±0.5 seconds	No visible damage
Resistance to Solvent	MIL-STD-202F-method 215;	Isopropylalcohol (C ₃ H ₇ OH) or dichloromethane	No smeared
	IEC 60115-1 4.29	(CH ₂ Cl ₂) followed by brushing	
Humidity (steady state)	JIS C 5202 7.5;	1,000 hours; 40±2 °C; 93(+2/-3)% RH	±2.0%
	IEC 60115-8 4.24.8	RCWW applied for 1.5 hours on and 0.5 hour off	
Leaching	EIA/IS 4.13B;	Solder bath at 260±5 °C	No visible damage
	IEC 60115-8 4.18	Dipping time: 30±1 seconds	

Table 5 Criteria of rated continued working voltage and overload voltage

TYPE	RL0402	RL0603	RL0805	RL1206	RL1210	RL1218	RL2010	RL2512
Voltage (DC/unit: V); (AC/ unit: V _{rms})	100	100	300	500	500	500	500	500

勝特力材料 886-3-5753170
勝特力电子(上海) 86-21-54151736
勝特力电子(深圳) 86-755-83298787
Http://www.100y.com.tw

REVISION HISTORY

REVISION	DATE	CHANGE NOTIFICATION	DESCRIPTION
Version 2	Jul 15, 2005	-	- Ordering example revised
Version 1	Apr 15, 2005	-	- Size 1218 extended - Test method and procedure updated - PE tape added (paper tape will be replaced by PE tape)
Version 0	Nov. 10, 2003	-	- First issue of this specification

勝特力材料 886-3-5753170
勝特力电子(上海) 86-21-54151736
勝特力电子(深圳) 86-755-83298787
Http://www.100y.com.tw