

DATA SHEET

勝特力材料 886-3-5753170
勝特力电子(上海) 86-21-54151736
勝特力电子(深圳) 86-755-83298787
[Http://www.100y.com.tw](http://www.100y.com.tw)

PMBFJ174 to 177 P-channel silicon field-effect transistors

Product specification
File under Discrete Semiconductors, SC07

April 1995

P-channel silicon field-effect transistors

PMBFJ174 to 177

DESCRIPTION

Silicon symmetrical p-channel junction FETs in plastic microminiature SOT23 envelopes. They are intended for application with analogue switches, choppers, commutators etc. using SMD technology. A special feature is the interchangeability of the drain and source connections.

PINNING

- 1 = drain
- 2 = source
- 3 = gate

Note

1. Drain and source are interchangeable.

Marking codes:

- 174 : p6X
- 175 : p6W
- 176 : p6S
- 177 : p6Y

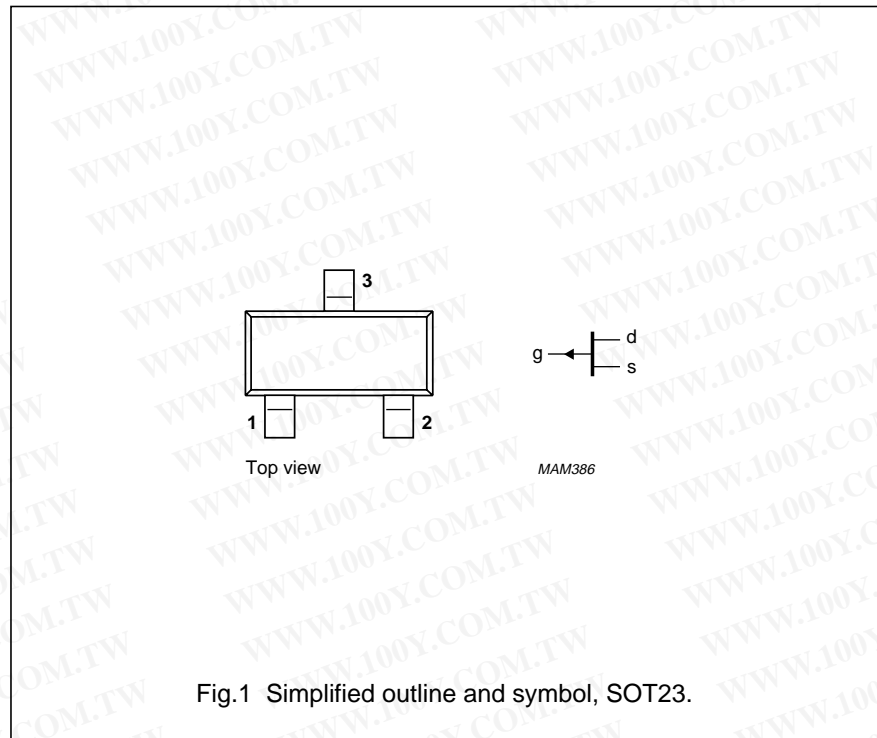

QUICK REFERENCE DATA

Drain-source voltage	$\pm V_{DS}$	max.	30	V		
Gate-source voltage	V_{GS0}	max.	30	V		
Gate current	$-I_G$	max.	50	mA		
Total power dissipation up to $T_{amb} = 25\text{ }^\circ\text{C}$	P_{tot}	max.	300	mW		
Drain current $-V_{DS} = 15\text{ V}; V_{GS} = 0$	$-I_{DSS}$		PMBFJ174	175	176	177
		>	20	7	2	1,5 mA
		<	135	70	35	20 mA
Drain-source ON-resistance $-V_{DS} = 0,1\text{ V}; V_{GS} = 0$	$R_{DS\ on}$	<	85	125	250	300 Ω

勝特力材料 886-3-5753170
 勝特力电子(上海) 86-21-54151736
 勝特力电子(深圳) 86-755-83298787
[Http://www.100y.com.tw](http://www.100y.com.tw)

P-channel silicon field-effect transistors

PMBFJ174 to 177

RATINGS

Limiting values in accordance with the Absolute Maximum System (IEC 134)

Drain-source voltage	$\pm V_{DS}$	max.	30	V
Gate-source voltage	V_{GSO}	max.	30	V
Gate-drain voltage	V_{GDO}	max.	30	V
Gate current (d.c.)	$-I_G$	max.	50	mA
Total power dissipation up to $T_{amb} = 25\text{ }^{\circ}\text{C}^{(1)}$	P_{tot}	max.	300	mW
Storage temperature range	T_{stg}		-65 to +150	$^{\circ}\text{C}$
Junction temperature	T_j	max.	150	$^{\circ}\text{C}$

THERMAL RESISTANCE

From junction to ambient in free air	$R_{th\ j-a}$	=	430	K/W
--------------------------------------	---------------	---	-----	-----

STATIC CHARACTERISTICS $T_j = 25\text{ }^{\circ}\text{C}$ unless otherwise specified

		PMBFJ174	175	176	177
Gate cut-off current $V_{GS} = 20\text{ V}; V_{DS} = 0$	I_{GSS}	< 1	1	1	1 nA
Drain cut-off current $-V_{DS} = 15\text{ V}; V_{GS} = 10\text{ V}$	$-I_{DSX}$	< 1	1	1	1 nA
Drain current $-V_{DS} = 15\text{ V}; V_{GS} = 0$	$-I_{DSS}$	> 20 < 135	7 70	2 35	1,5 mA 20 mA
Gate-source breakdown voltage $I_G = 1\text{ }\mu\text{A}; V_{DS} = 0$	$V_{(BR)GSS}$	> 30	30	30	30 V
Gate-source cut-off voltage $-I_D = 10\text{ nA}; V_{DS} = -15\text{ V}$	$V_{GS\ off}$	> 5 < 10	3 6	1 4	0,8 V 2,25 V
Drain-source ON-resistance $-V_{DS} = 0,1\text{ V}; V_{GS} = 0$	$R_{DS\ on}$	< 85	125	250	300 Ω

Note

1. Mounted on a ceramic substrate of 8 mm × 10 mm × 0,7 mm.

勝特力材料 886-3-5753170
 勝特力电子(上海) 86-21-54151736
 勝特力电子(深圳) 86-755-83298787
[Http://www.100y.com.tw](http://www.100y.com.tw)

P-channel silicon field-effect transistors

PMBFJ174 to 177

DYNAMIC CHARACTERISTICS

$T_j = 25\text{ }^\circ\text{C}$ unless otherwise specified

Input capacitance, $f = 1\text{ MHz}$

$V_{GS} = 10\text{ V}; V_{DS} = 0\text{ V}$

$V_{GS} = V_{DS} = 0$

Feedback capacitance, $f = 1\text{ MHz}$

$V_{GS} = 10\text{ V}; V_{DS} = 0\text{ V}$

Switching times (see Fig.2 + 3)

Delay time

Rise time

Turn-on time

Storage temperature

Fall time

Turn-off time

Test conditions:

C_{is}	typ.	8				pF
C_{is}	typ.	30				pF
C_{rs}	typ.	4				pF
		PMBFJ174	175	176	177	
t_d	typ.	2	5	15	20	ns
t_r	typ.	5	10	20	25	ns
t_{on}	typ.	7	15	35	45	ns
t_s	typ.	5	10	15	20	ns
t_f	typ.	10	20	20	25	ns
t_{off}	typ.	15	30	35	45	ns
$-V_{DD}$		10	6	6	6	V
$V_{GS\ off}$		12	8	6	3	V
R_L		560	1200	2000	2900	Ω
$V_{GS\ on}$		0	0	0	0	V

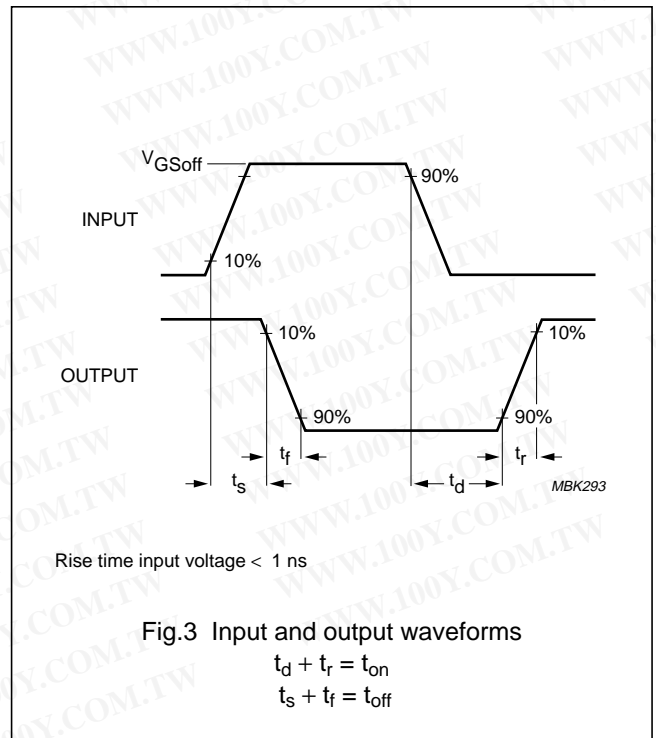
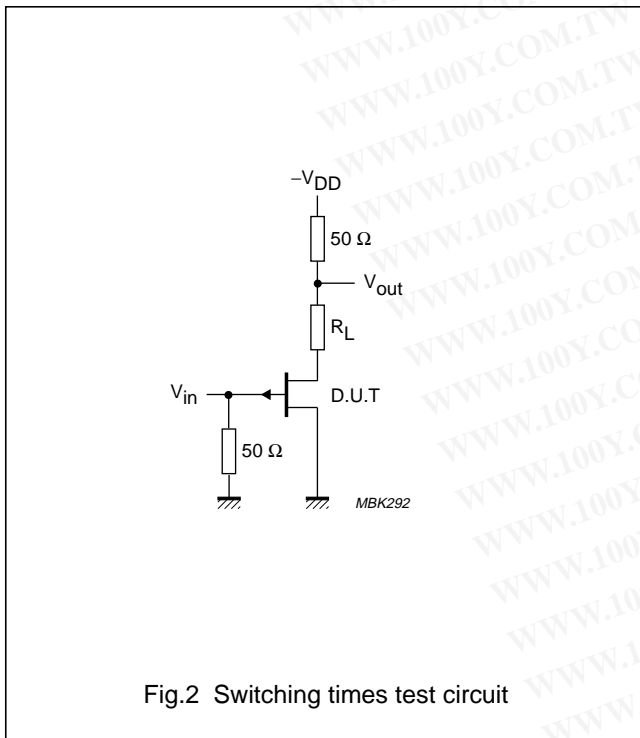

P-channel silicon field-effect transistors

PMBFJ174 to 177

PACKAGE OUTLINE

Plastic surface mounted package; 3 leads

SOT23

勝特力材料 886-3-5753170
 勝特力电子(上海) 86-21-54151736
 勝特力电子(深圳) 86-755-83298787
[Http://www.100y.com.tw](http://www.100y.com.tw)

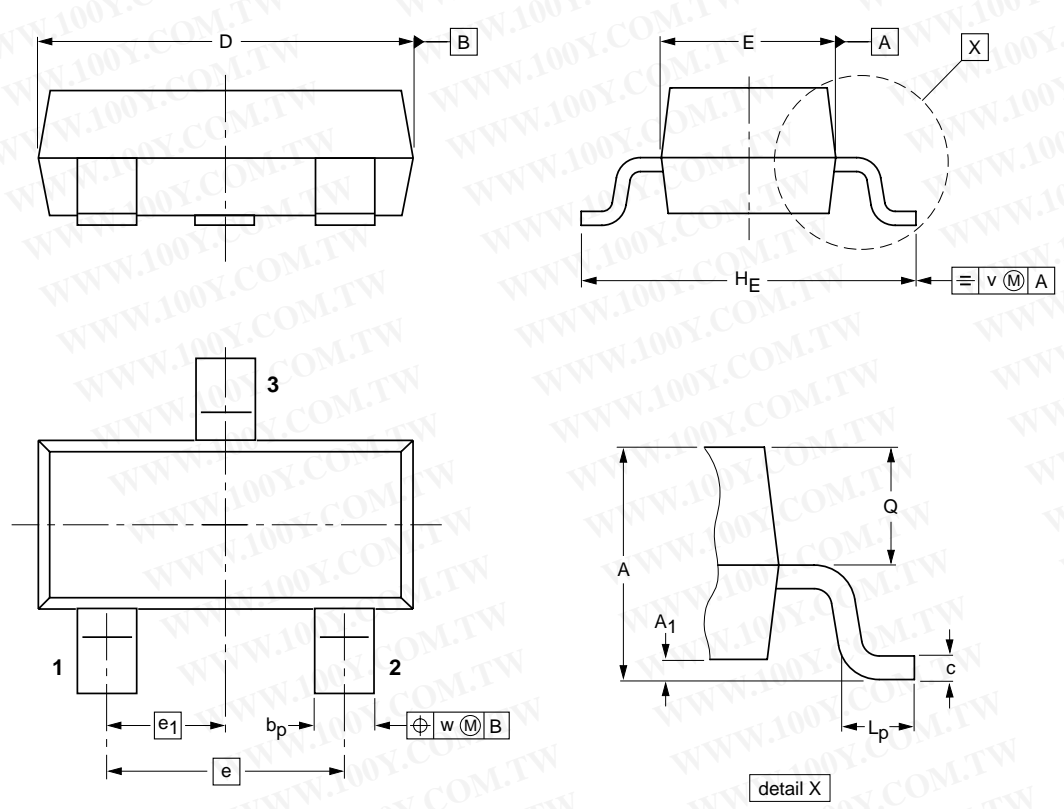

DIMENSIONS (mm are the original dimensions)

UNIT	A	A ₁ max.	b _p	c	D	E	e	e ₁	H _E	L _p	Q	v	w
mm	1.1 0.9	0.1	0.48 0.38	0.15 0.09	3.0 2.8	1.4 1.2	1.9	0.95	2.5 2.1	0.45 0.15	0.55 0.45	0.2	0.1

OUTLINE VERSION	REFERENCES				EUROPEAN PROJECTION	ISSUE DATE
	IEC	JEDEC	EIAJ			
SOT23						97-02-28

P-channel silicon field-effect transistors

PMBFJ174 to 177

DEFINITIONS

Data sheet status	
Objective specification	This data sheet contains target or goal specifications for product development.
Preliminary specification	This data sheet contains preliminary data; supplementary data may be published later.
Product specification	This data sheet contains final product specifications.
Short-form specification	The data in this specification is extracted from a full data sheet with the same type number and title. For detailed information see the relevant data sheet or data handbook.
Limiting values	
Limiting values given are in accordance with the Absolute Maximum Rating System (IEC 134). Stress above one or more of the limiting values may cause permanent damage to the device. These are stress ratings only and operation of the device at these or at any other conditions above those given in the Characteristics sections of the specification is not implied. Exposure to limiting values for extended periods may affect device reliability.	
Application information	
Where application information is given, it is advisory and does not form part of the specification.	

LIFE SUPPORT APPLICATIONS

These products are not designed for use in life support appliances, devices, or systems where malfunction of these products can reasonably be expected to result in personal injury. Philips customers using or selling these products for use in such applications do so at their own risk and agree to fully indemnify Philips for any damages resulting from such improper use or sale.

勝特力材料 886-3-5753170
 勝特力电子(上海) 86-21-54151736
 勝特力电子(深圳) 86-755-83298787
[Http://www.100y.com.tw](http://www.100y.com.tw)