

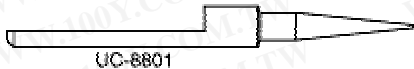









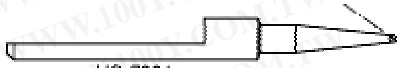

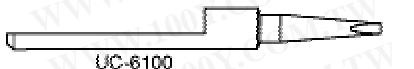

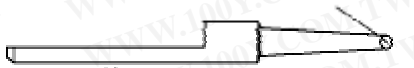





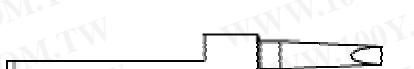



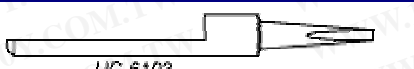

Plato Tips to fit Weller/Ungar 9900AS,









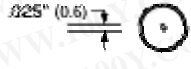

2110AS and UTC-Series Soldering Stations

Weller/Ungar	Plato	PLATO TIP & ORDER NUMBER
9010	UC-8801	 .015" (0.4)  UC-8801
9011	UC-7001	 .035" (0.9)  UC-7001
9012	UC-6100	 .050" (1.3)  UC-6100 .015" (0.4)
9013	UC-7002	 .065" (1.7)  UC-7002
9014	UC-7003	 .030" (0.8)  UC-7003
9015	UC-6101	 .065" (1.7)  UC-6101 .020" (0.5)
9016	UC-6110	 .090" (2.3)  UC-6110 .015" (0.4)
9017	UC-6102	 .030" (0.8)  UC-6102 .020" (0.5)
9018	UC-6103	 .050" (1.3)  UC-6103 .025" (0.6)
9019	UC-7004	 .030" (0.8)  UC-7004
9050	UC-8802	 .020" (0.5)  UC-8802
9051	UC-6104	 .120" (3.0)  UC-6104 .025" (0.6)
9052	UC-7005	 .030" (0.8)  UC-7005

Plato High Capacity Tips to fit Weller/Ungar 9900AS,



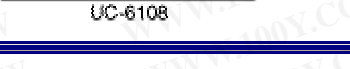



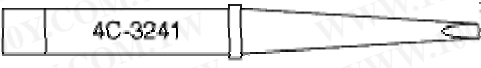

勝特力材料 886-3-5753170
 勝特力电子(上海) 86-21-54151736
 勝特力电子(深圳) 86-755-83298787
[Http://www.100y.com.tw](http://www.100y.com.tw)

2110AS and UTC-Series Soldering Stations

Weller/Ungar [?] / _{sup} >	Plato [?] / _{font} >	PLATO [?] / _{sup} > TIP & ORDER NUMBER	
9056	UC-8803	 UC-8803	
9057	UC-6105	 UC-6105	
9058	UC-6106	 UC-6106	
9059	UC-6107	 UC-6107	
9060	UC-6108	 UC-6108	
9061	UC-6109	 UC-6109	

Plato[?]/_{sup}> Tips to fit Weller[?]/_{sup}>

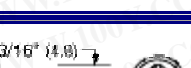
W60P Soldering Irons

Weller [?] / _{sup} >	Plato [?] / _{font} >	PLATO [?] / _{sup} > TIP & ORDER NUMBER	
CT5A	4C-3241	 4C-3241	
CT5B	4C-3242	 4C-3242	
CT5C	4C-3243	 4C-3243	
CT5D	4C-3244	 4C-3244	
CT5E	4C-1080	 4C-1080	

Plato[?]/_{sup}> Tips to fit Weller[?]/_{sup}>





勝特力材料 886-3-5753170
 勝特力电子(上海) 86-21-54151736
 勝特力电子(深圳) 86-755-83298787
[Http://www.100y.com.tw](http://www.100y.com.tw)

W100PG Soldering Irons







Weller ^{®/sup>}	Plato ^{®/font>}	PLATO ^{®/sup>} TIP & ORDER NUMBER
CT6C	6C-3219	
CT6D	6C-3220	
CT6E	6C-3221	
CT6F	6C-1083	





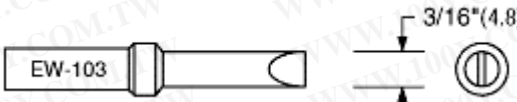





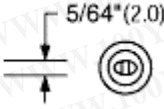

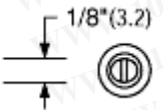

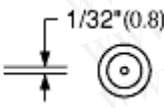

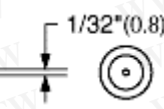
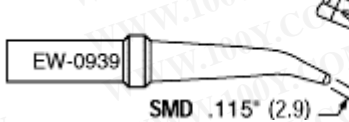
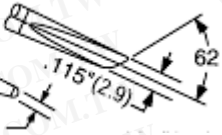

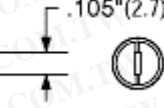

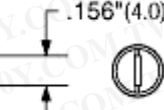

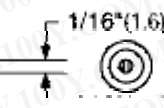
Plato® Tips to fit Weller® MC-5001, EC-1002, EC-2002, WTL1000-2, DEC-1001, DTL-1000 Soldering Stations used with EC1302A Soldering Iron Handpiece

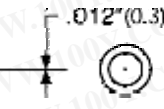

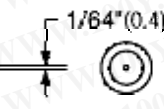

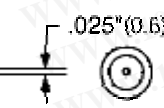

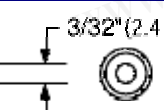

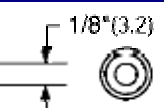

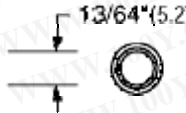

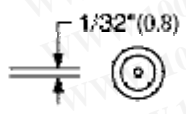

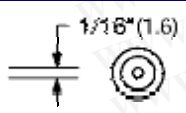
Weller®	Plato®	PLATO® TIP & ORDER NUMBER
EPH101	RX-4762	
EPH102	RX-402	
EPH103	RX-513	
EPH104	RX-404	
EPH105	RX-515	
EPH106	RX-306	
EPH107	RX-307	
EPH109	RX-409	
EPH110	RX-401	

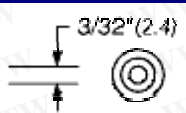
EPH111	RX-4764	
EPH112	RX-4763	
---	RX-5567	
---	RX-5568	
		 Typical Tip Drawing

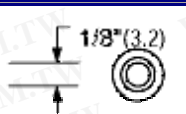
Plato Tips to fit Weller® Stations WES50, EC-1002, EC-2002, MC-5001,
 WCC-100, WTL-1000, DTL-1000, DEC-1000 used with EC1201A,
 EC1201AFE, EX1201AFE & WCC-101 Soldering Iron Handpiece

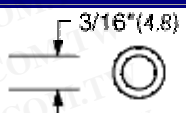

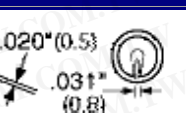

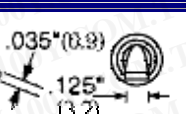
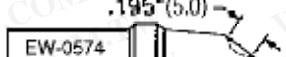
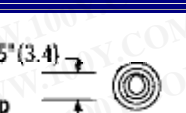



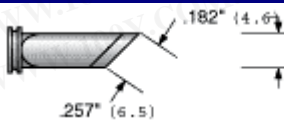









































Weller®	Plato®	PLATO® TIP & ORDER NUMBER
ETA	EW-303	
ETB	EW-305	
ETC	EW-307	
ETD	EW-103	
---	EW-105	
ETH	EW-301	
ETJ	EW-302	
ETK	EW-304	

ETL	EW-306		
ETM	EW-308		
ETO	EW-404		
ETP	EW-403		
ET-JL	NEW EW-0939		
ET-SMD 2.5mm	NEW EW-0940		
ET-SMD 3.8mm	NEW EW-0941		
ETR	EW-101		
---	EW-4796		
ETS	EW-402		
ETT	EW-401		
ETBS	EW-405		
ETCS	EW-407		

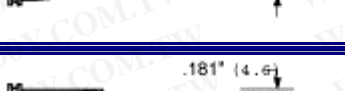
ETDS	EW-409		
----	EW-511		
ETAA	EW-513		
ETBB	EW-515		
ETCC	EW-517		
ETDD	EW-519		
----	EW-0602		
ET-MX	EW-0603		
----	EW-0574		

Plato Tips to fit Weller® WS 80, WSD 80, WSD 130
 WSD 150 Soldering Stations and WSP 80
 and MPR 80 Soldering Pencils



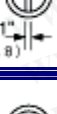

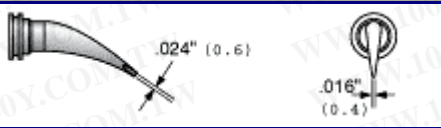
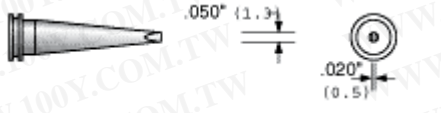
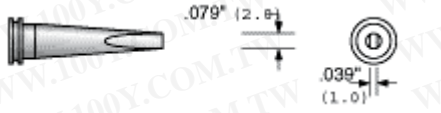
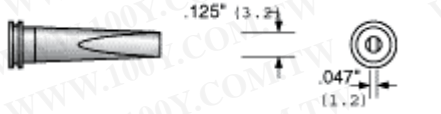
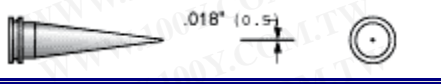

Weller®	Plato®	PLATO TIP & ORDER NUMBER
---	MS-0105	
---	MS-0201	

---	MS-4140		$.031''$ (0.8) 	
LT1	MS-4120		$.010''$ (0.25) 	
LT1L	MS-4110		$.010''$ (0.25) 	
LT1LX	MS-4101		$.010''$ (0.25) 	
LT1S	MS-4100		$.063''$ (1.6)  $.010''$ (0.25) 	
LT1SLX	MS-4125		$.012''$ (0.3) 	
LT4	MS-5160		$.047''$ (1.2) 	
LTA	MS-3200		$.063''$ (1.6)  $.031''$ (0.8) 	
LTAS	MS-4150		$.063''$ (1.6) 	
LTB	MS-3300		$.094''$ (2.4)  $.031''$ (0.8) 	
LTC	MS-3400		$.125''$ (3.2)  $.031''$ (0.8) 	
LTCS	MS-4160		$.126''$ (3.2) 	
LTD	MS-3600		$.181''$ (4.6)  $.031''$ (0.8) 	
LTGW	MS-0100		$.122''$ (3.1)  $.084''$ (2.1) 	
LTH	MS-3110		$.031''$ (0.8)  $.016''$ (0.4) 	

LTHX	MS-3101	
LTK	MS-3150	
LTL	MS-3250	
LTM	MS-3450	
LTS	MS-4130	

Plato[?] Tips to fit Weller[?]



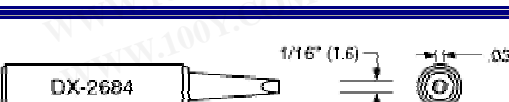









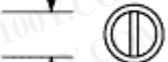

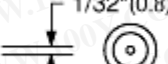

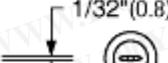

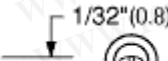

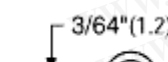

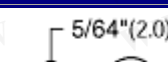

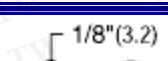
Micro-Soldering Pencil MLR 20, MPR 30









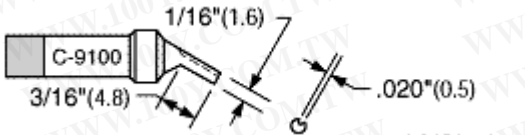
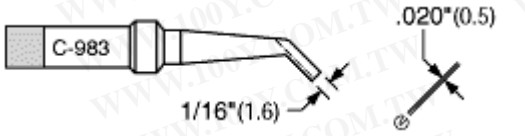

Weller [?]	Plato [?]	PLATO [?] TIP & ORDER NUMBER
MT-1	DX-4771	
MT-1S	DX-4814	
MT-4	DX-5590	
---	DX-5688	
---	DX-2727	
MPT-6	DX-1500	
MT-A	DX-2684	

MT-B	DX-2726	
MT-H	DX-2683	
MTX	DX-2987	
---	DX-4977	
---	DX-5550	
MT-GW	DX-5551	
---	DX-0600	
MT-JL	DX-0601	

Plato Tips to fit Weller® WTCPL, WTCPL, WTCPR
 WTCPS, and WTCPT Soldering Stations with
 TC201T Soldering Iron Handpiece

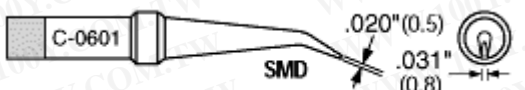
Weller®	Plato®	PLATO TIP & ORDER NUMBER	
PTA	C-3039		
PTB	C-3040		
PTC	C-3036		

PTD	C-1016		$3/16''(4.8)$ 
PTE	C-1017		$7/32''(5.6)$ 
PTF	C-593		$1/32''(0.8)$ 
PTH	C-3100		$1/32''(0.8)$ 
PTJ	C-3865		$1/32''(0.8)$ 
PTK	C-3043		$3/64''(1.2)$ 
PTL	C-3044		$5/64''(2.0)$ 
PTM	C-3102		$1/8''(3.2)$ 
PTO	C-4223		$1/32''(0.8)$ 
PTP	C-462		$1/32''(0.8)$ 
PTQ	C-5101		$1/16''(1.6)$ 
PTR	C-1021		$1/16''(1.6)$ 
---	C-4794		$.012''(0.3)$ 

PTS	C-494	
PTT	C-4309	
PTX	C-9100	
PTZ	C-983	
PTAA	C-5139	
PTBB	C-5143	
PTCC	C-5141	
PTDD	C-5142	
---	C-0601	
PTMX	NEW C-0602	
---	C-0551	
Weller®	Plato®	PLATO® TIP & ORDER NUMBER
ST-1	44-3870	

ST-2	44-3871	
ST-3	44-3872	
ST-4	44-1312	
ST-6	44-3873	
ST-7	44-8182	
ST-8	41-1313	

勝特力材料 886-3-5753170
 勝特力电子(上海) 86-21-54151736
 勝特力电子(深圳) 86-755-83298787
[Http://www.100y.com.tw](http://www.100y.com.tw)