

DATA SHEET

勝特力材料 886-3-5753170
勝特力电子(上海) 86-21-54151736
勝特力电子(深圳) 86-755-83298787
[Http://www.100y.com.tw](http://www.100y.com.tw)

74LVC374A

Octal D-type flip-flop with 5 V
tolerant inputs/outputs; positive
edge-trigger; 3-state

Product specification
Supersedes data of 1998 July 29

2003 May 14

Octal D-type flip-flop with 5 V tolerant inputs/outputs; positive edge-trigger; 3-state

74LVC374A

FEATURES

- 5 V tolerant inputs/outputs; for interfacing with 5 V logic
- Wide supply voltage range from 1.2 to 3.6 V
- Inputs accept voltages up to 5.5 V
- CMOS low power consumption
- Direct interface with TTL levels
- High-impedance when $V_{CC} = 0$ V
- 8-bit positive edge-triggered register
- Independent register and 3-state buffer operation
- Complies with JEDEC standard no. 8-1A
- ESD protection:
HBM EIA/JESD22-A114-A exceeds 2000 V
MM EIA/JESD22-A115-A exceeds 200 V.
- Specified from -40 to $+85$ °C and -40 to $+125$ °C.

勝特力材料 886-3-5753170
 勝特力电子(上海) 86-21-54151736
 勝特力电子(深圳) 86-755-83298787
[Http://www.100y.com.tw](http://www.100y.com.tw)

DESCRIPTION

The 74LVC374A is a high-performance, low-power, low-voltage, Si-gate CMOS device, superior to most advanced CMOS compatible TTL families.

Inputs can be driven from either 3.3 or 5 V devices. In 3-state operation, outputs can handle 5 V. This feature allows the use of these devices as translators in a mixed 3.3 and 5 V environment.

The 74LVC374A is an octal D-type flip-flop featuring separate D-type inputs for each flip-flop and 3-state outputs for bus-oriented applications. A clock input (CP) and an outputs enable input (\overline{OE}) are common to all flip-flops.

The eight flip-flops will store the state of their individual D-inputs that meet the set-up and hold times requirements on the LOW-to-HIGH CP transition.

When pin \overline{OE} is LOW, the contents of the eight flip-flops is available at the outputs. When pin \overline{OE} is HIGH, the outputs go to the high-impedance OFF-state. Operation of the \overline{OE} input does not affect the state of the flip-flops.

The 74LVC374A is functionally identical to the 74LVC574A, but the 74LVC574A has a different pin arrangement.

QUICK REFERENCE DATA

$GND = 0$ V; $T_{amb} = 25$ °C; $t_r = t_f \leq 2.5$ ns.

SYMBOL	PARAMETER	CONDITIONS	TYPICAL	UNIT
t_{PHL}/t_{PLH}	propagation delay CP to Qn	$C_L = 50$ pF; $V_{CC} = 3.3$ V	2.7	ns
f_{max}	maximum clock frequency		100	MHz
C_I	input capacitance		4.0	pF
C_{PD}	power dissipation capacitance per gate	$V_{CC} = 3.3$ V; notes 1 and 2	15	pF

Notes

1. C_{PD} is used to determine the dynamic power dissipation (P_D in μ W).

$$P_D = C_{PD} \times V_{CC}^2 \times f_i \times N + \Sigma(C_L \times V_{CC}^2 \times f_o) \text{ where:}$$

f_i = input frequency in MHz;

f_o = output frequency in MHz;

C_L = output load capacitance in pF;

V_{CC} = supply voltage in Volts;

N = total load switching outputs;

$\Sigma(C_L \times V_{CC}^2 \times f_o)$ = sum of the outputs.

2. The condition is $V_I = GND$ to V_{CC} .

Octal D-type flip-flop with 5 V tolerant inputs/outputs; positive edge-trigger; 3-state

74LVC374A

FUNCTION TABLE

See note 1.

OPERATING MODE	INPUT			INTERNAL FLIP-FLOP	OUTPUT
	\overline{OE}	CP	Dn		Qn
Load and read register	L	↑	l	L	L
	L	↑	h	H	H
Load register and disable outputs	H	↑	l	L	Z
	H	↑	h	H	Z

Note

- H = HIGH voltage level;
h = HIGH voltage level one set-up time prior to the LOW-to-HIGH CP transition;
L = LOW voltage level;
l = LOW voltage level one set-up time prior to the LOW-to-HIGH CP transition;
Z = high-impedance OFF-state;
↑ = LOW-to-HIGH clock transition.

勝特力材料 886-3-5753170
 勝特力电子(上海) 86-21-54151736
 勝特力电子(深圳) 86-755-83298787
[Http://www.100y.com.tw](http://www.100y.com.tw)

ORDERING INFORMATION

TYPE NUMBER	PACKAGE				
	TEMPERATURE RANGE	PINS	PACKAGE	MATERIAL	CODE
74LVC374AD	-40 to +125 °C	20	SO20	plastic	SOT163-1
74LVC374ADB	-40 to +125 °C	20	SSOP20	plastic	SOT339-1
74LVC374APW	-40 to +125 °C	20	TSSOP20	plastic	SOT360-1
74LVC374ABQ	-40 to +125 °C	20	DHVQFN20	plastic	SOT764-1

PINNING

PIN	SYMBOL	DESCRIPTION
1	\overline{OE}	output enable input (active LOW)
2	Q0	3-state flip-flop output
3	D0	data input
4	D1	data input
5	Q1	3-state flip-flop output
6	Q2	3-state flip-flop output
7	D2	data input
8	D3	data input
9	Q3	3-state flip-flop output
10	GND	ground (0 V)

PIN	SYMBOL	DESCRIPTION
11	CP	clock input (LOW-to-HIGH, edge-triggered)
12	Q4	3-state flip-flop output
13	D4	data input
14	D5	data input
15	Q5	3-state flip-flop output
16	Q6	3-state flip-flop output
17	D6	data input
18	D7	data input
19	Q7	3-state flip-flop output
20	V _{CC}	supply voltage

Octal D-type flip-flop with 5 V tolerant inputs/outputs;
positive edge-trigger; 3-state

74LVC374A

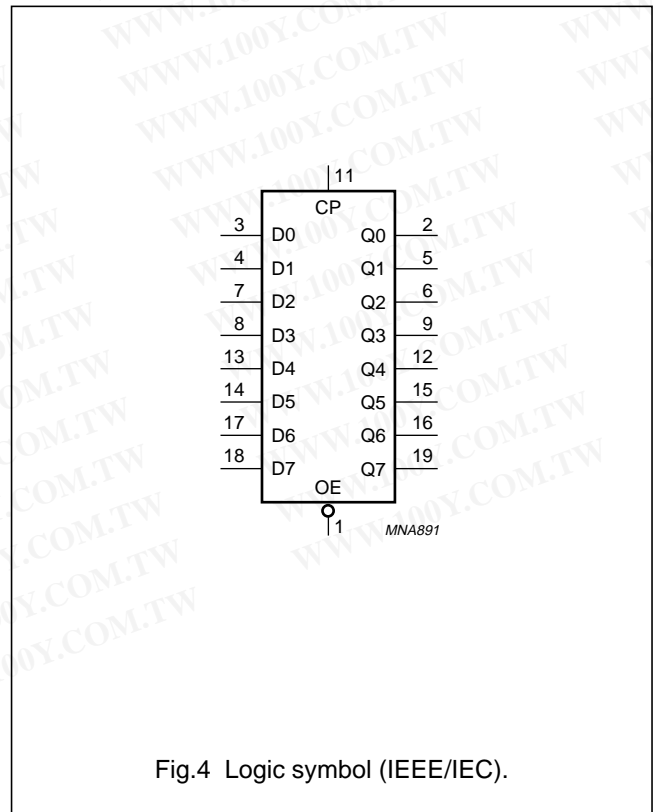
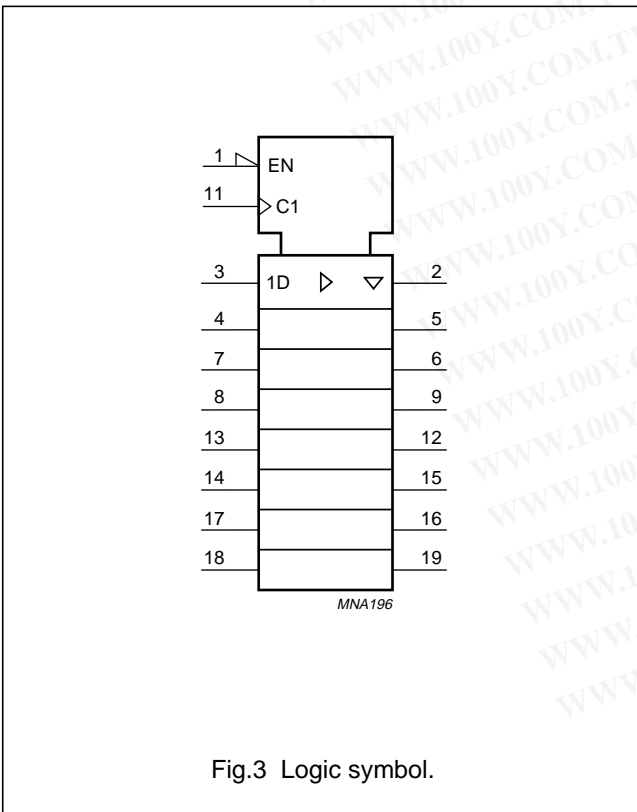
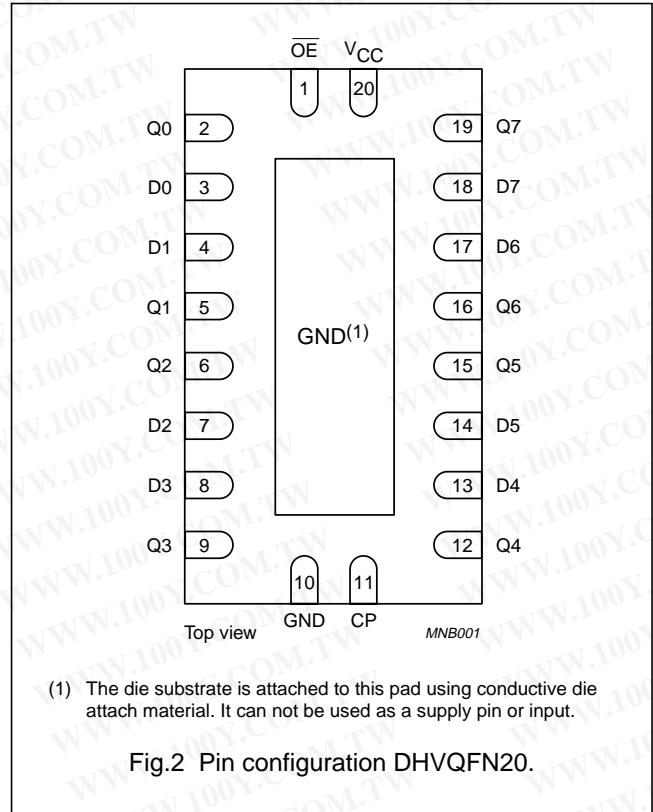
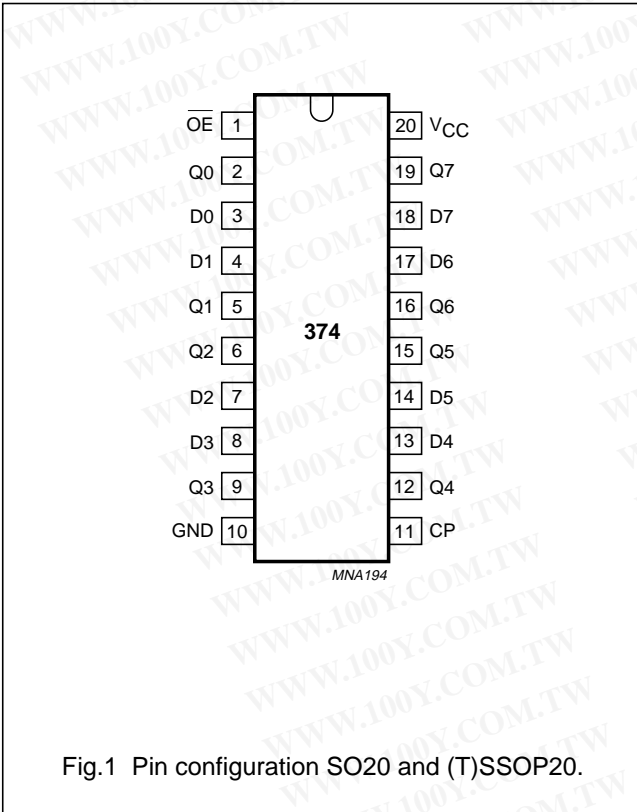

Octal D-type flip-flop with 5 V tolerant inputs/outputs;
positive edge-trigger; 3-state

74LVC374A

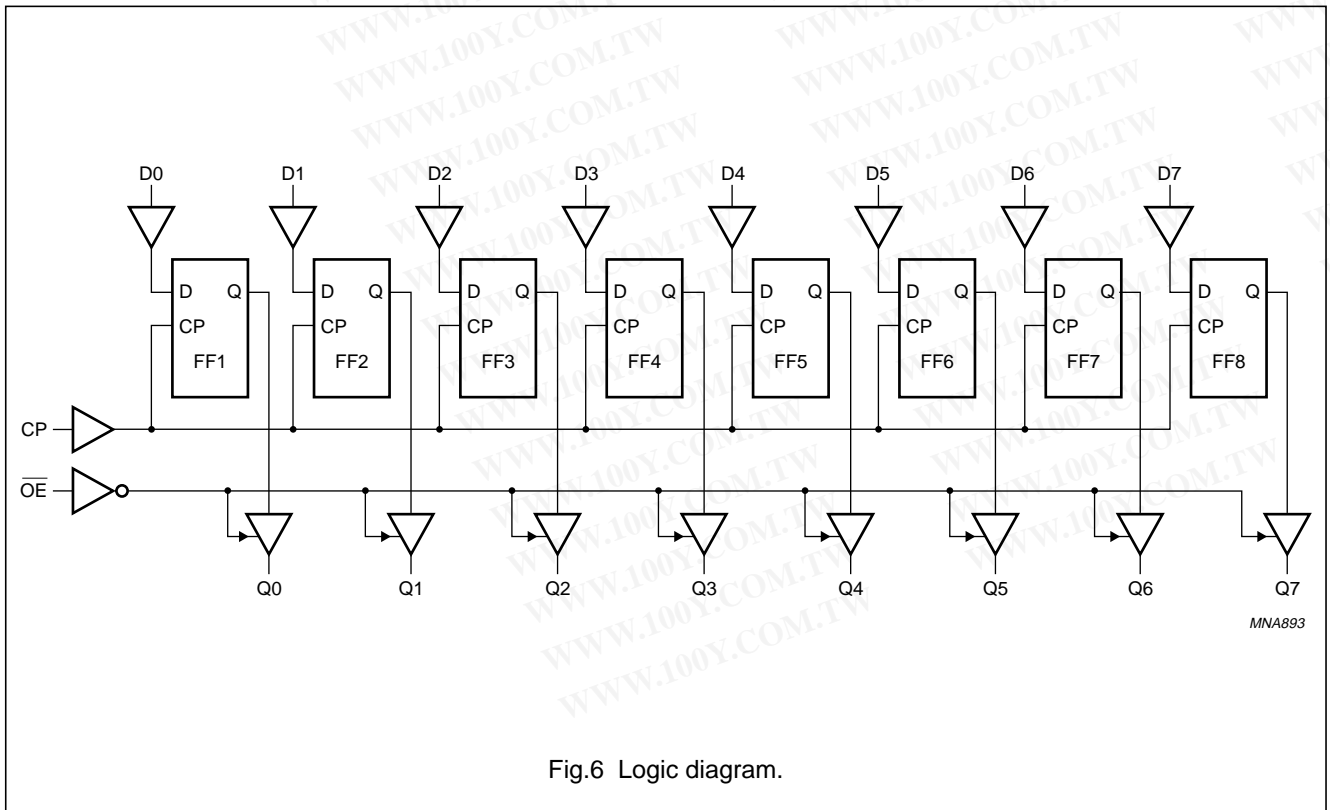
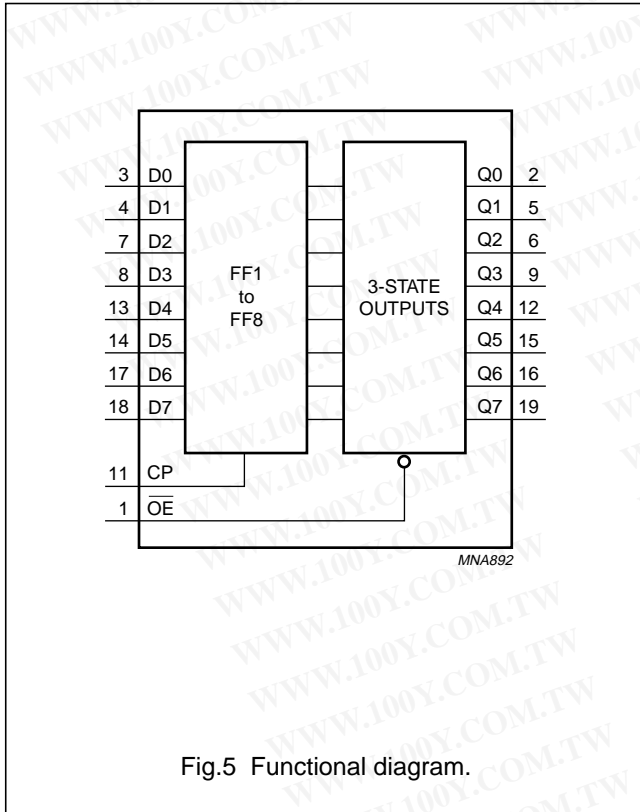

Octal D-type flip-flop with 5 V tolerant inputs/outputs;
positive edge-trigger; 3-state

74LVC374A

RECOMMENDED OPERATING CONDITIONS

SYMBOL	PARAMETER	CONDITIONS	MIN.	MAX.	UNIT
V _{CC}	supply voltage	for maximum speed performance	2.7	3.6	V
		for low-voltage applications	1.2	3.6	V
V _I	input voltage		0	5.5	V
V _O	output voltage	output HIGH or LOW state	0	V _{CC}	V
		output 3-state	0	5.5	V
T _{amb}	operating ambient temperature	in free air	-40	+125	°C
t _r , t _f	input rise and fall times	V _{CC} = 1.2 to 2.7 V	0	20	ns/V
		V _{CC} = 2.7 to 3.6 V	0	10	ns/V

LIMITING VALUES

In accordance with the Absolute Maximum Rating System (IEC 60134); voltages are referenced to GND (ground = 0 V).

SYMBOL	PARAMETER	CONDITIONS	MIN.	MAX.	UNIT
V _{CC}	supply voltage		-0.5	+6.5	V
I _{IK}	input diode current	V _I < 0	-	-50	mA
V _I	input voltage	note 1	-0.5	+6.5	V
I _{OK}	output diode current	V _O > V _{CC} or V _O < 0	-	±50	mA
V _O	output voltage	output HIGH or LOW state; note 1	-0.5	V _{CC} + 0.5	V
		output 3-state; note 1	-0.5	+6.5	V
I _O	output source or sink current	V _O = 0 to V _{CC}	-	±50	mA
I _{CC} , I _{GND}	V _{CC} or GND current		-	±100	mA
T _{stg}	storage temperature		-65	+150	°C
P _{tot}	power dissipation	T _{amb} = -40 to +125 °C; note 2	-	500	mW

Notes

- The input and output voltage ratings may be exceeded if the input and output current ratings are observed.
- For SO20 packages: above 70 °C derate linearly with 8 mW/K.
For SSOP20 and TSSOP20 packages: above 60 °C derate linearly with 5.5 mW/K.
For DHVQFN20 packages: above 60 °C derate linearly with 4.5 mW/K.

勝特力材料 886-3-5753170
 勝特力电子(上海) 86-21-54151736
 勝特力电子(深圳) 86-755-83298787
[Http://www.100y.com.tw](http://www.100y.com.tw)

Octal D-type flip-flop with 5 V tolerant inputs/outputs; positive edge-trigger; 3-state

74LVC374A

DC CHARACTERISTICS

At recommended operating conditions; voltages are referenced to GND (ground = 0 V).

SYMBOL	PARAMETER	TEST CONDITIONS		MIN.	TYP.	MAX.	UNIT
		OTHER	V _{CC} (V)				
T_{amb} = -40 to +85 °C; note 1							
V _{IH}	HIGH-level input voltage		1.2	V _{CC}	–	–	V
			2.7 to 3.6	2.0	–	–	V
V _{IL}	LOW-level input voltage		1.2	–	–	GND	V
			2.7 to 3.6	–	–	0.8	V
V _{OH}	HIGH-level output voltage	V _I = V _{IH} or V _{IL}	2.7 to 3.6	V _{CC} – 0.2	–	–	V
		I _O = –100 μA	2.7	V _{CC} – 0.5	–	–	V
		I _O = –12 mA	3.0	V _{CC} – 0.6	–	–	V
		I _O = –24 mA	3.0	V _{CC} – 0.8	–	–	V
V _{OL}	LOW-level output voltage	V _I = V _{IH} or V _{IL}	2.7 to 3.6	–	–	0.20	V
		I _O = 100 μA	2.7	–	–	0.40	V
		I _O = 24 mA	3.0	–	–	0.55	V
I _{LI}	input leakage current	V _I = 5.5 V or GND	3.6	–	±0.1	±5	μA
I _{OZ}	3-state output OFF-state current	V _I = V _{IH} or V _{IL} ; V _O = 5.5 V or GND	3.6	–	±0.1	±5	μA
I _{off}	power-off leakage supply	V _I or V _O = 5.5 V	0.0	–	±0.1	±10	μA
I _{CC}	quiescent supply current	V _I = V _{CC} or GND; I _O = 0	3.6	–	0.1	10	μA
ΔI _{CC}	additional quiescent supply current per input pin	V _I = V _{CC} – 0.6 V; I _O = 0	2.7 to 3.6	–	5	500	μA

勝特力材料 886-3-5753170
 勝特力电子(上海) 86-21-54151736
 勝特力电子(深圳) 86-755-83298787
[Http://www.100y.com.tw](http://www.100y.com.tw)

Octal D-type flip-flop with 5 V tolerant inputs/outputs;
positive edge-trigger; 3-state

74LVC374A

SYMBOL	PARAMETER	TEST CONDITIONS		MIN.	TYP.	MAX.	UNIT
		OTHER	V _{CC} (V)				
T_{amb} = -40 to +125 °C							
V _{IH}	HIGH-level input voltage		1.2	V _{CC}	-	-	V
			2.7 to 3.6	2.0	-	-	V
V _{IL}	LOW-level input voltage		1.2	-	-	GND	V
			2.7 to 3.6	-	-	0.8	V
V _{OH}	HIGH-level output voltage	V _I = V _{IH} or V _{IL}	2.7 to 3.6	V _{CC} - 0.3	-	-	V
		I _O = -100 μA	2.7	V _{CC} - 0.65	-	-	V
		I _O = -12 mA	3.0	V _{CC} - 0.75	-	-	V
		I _O = -18 mA	3.0	V _{CC} - 1	-	-	V
V _{OL}	LOW-level output voltage	V _I = V _{IH} or V _{IL}	2.7 to 3.6	-	-	0.3	V
		I _O = 100 μA	2.7	-	-	0.6	V
		I _O = 12 mA	3.0	-	-	0.8	V
		I _O = 24 mA	3.0	-	-	0.8	V
I _{LI}	input leakage current	V _I = 5.5 V or GND	3.6	-	-	±20	μA
I _{OZ}	3-state output OFF-state current	V _I = V _{IH} or V _{IL} ; V _O = 5.5 V or GND	3.6	-	-	±20	μA
I _{off}	power-off leakage supply	V _I or V _O = 5.5 V	0.0	-	-	±20	μA
I _{CC}	quiescent supply current	V _I = V _{CC} or GND; I _O = 0	3.6	-	-	40	μA
ΔI _{CC}	additional quiescent supply current per input pin	V _I = V _{CC} - 0.6 V; I _O = 0	2.7 to 3.6	-	-	5000	μA

Note

1. All typical values are measured at V_{CC} = 3.3 V and T_{amb} = 25 °C.

勝特力材料 886-3-5753170
 勝特力电子(上海) 86-21-54151736
 勝特力电子(深圳) 86-755-83298787
[Http://www.100y.com.tw](http://www.100y.com.tw)

Octal D-type flip-flop with 5 V tolerant inputs/outputs; positive edge-trigger; 3-state

74LVC374A

AC CHARACTERISTICSGND = 0 V; $t_r = t_f \leq 2.5$ ns; $C_L = 50$ pF; $R_L = 500$ Ω .

SYMBOL	PARAMETER	TEST CONDITIONS		MIN.	TYP.	MAX.	UNIT
		WAVEFORM	V _{CC} (V)				
T_{amb} = -40 to +85 °C; note1							
t _{PHL} /t _{PLH}	propagation delay CP to Qn	Figs 7 and 10	1.2	–	16	–	ns
			2.7	1.5	2.9	8.0	ns
			3.0 to 3.6	1.5	2.7	7.0	ns
t _{PZH} /t _{PZL}	3-state output enable time OE to Qn	Figs 8 and 10	1.2	–	19	–	ns
			2.7	1.5	4.1	8.5	ns
			3.0 to 3.6	1.5	3.4	7.5	ns
t _{PHZ} /t _{PLZ}	3-state output disable time OE to Qn	Figs 8 and 10	1.2	–	8.0	–	ns
			2.7	1.5	2.7	7.0	ns
			3.0 to 3.6	1.5	2.4	6.0	ns
t _w	clock pulse width HIGH or LOW	Fig.7	1.2	–	–	–	ns
			2.7	3.0	–	–	ns
			3.0 to 3.6	3.0	1.5	–	ns
t _{su}	set-up time Dn to CP	Fig.9	1.2	–	–	–	ns
			2.7	2.0	–	–	ns
			3.0 to 3.6	2.0	0	–	ns
t _h	hold time Dn to CP	Fig.9	1.2	–	–	–	ns
			2.7	1.5	–	–	ns
			3.0 to 3.6	1.5	0.6	–	ns
f _{max}	maximum clock frequency	Fig.7	1.2	–	–	–	MHz
			2.7	80	–	–	MHz
			3.0 to 3.6	100	–	–	MHz
t _{sk(0)}	skew	note 2	3.0 to 3.6	–	–	1.0	ns

勝特力材料 886-3-5753170
 勝特力电子(上海) 86-21-54151736
 勝特力电子(深圳) 86-755-83298787
[Http://www.100y.com.tw](http://www.100y.com.tw)

Octal D-type flip-flop with 5 V tolerant inputs/outputs;
positive edge-trigger; 3-state

74LVC374A

SYMBOL	PARAMETER	TEST CONDITIONS		MIN.	TYP.	MAX.	UNIT
		WAVEFORM	V _{CC} (V)				
T_{amb} = -40 to +125 °C							
t _{PHL} /t _{PLH}	propagation delay CP to Qn	Figs 7 and 10	1.2	–	–	–	ns
			2.7	1.5	–	10.0	ns
			3.0 to 3.6	1.5	–	9.0	ns
t _{PZH} /t _{PZL}	3-state output enable time OE to Qn	Figs 8 and 10	1.2	–	–	–	ns
			2.7	1.5	–	11.0	ns
			3.0 to 3.6	1.5	–	9.5	ns
t _{PHZ} /t _{PLZ}	3-state output disable time OE to Qn	Figs 8 and 10	1.2	–	–	–	ns
			2.7	1.5	–	9.0	ns
			3.0 to 3.6	1.5	–	7.5	ns
t _w	clock pulse width HIGH or LOW	Fig.7	1.2	–	–	–	ns
			2.7	4.5	–	–	ns
			3.0 to 3.6	4.5	–	–	ns
t _{su}	set-up time Dn to CP	Fig.9	1.2	–	–	–	ns
			2.7	2.0	–	–	ns
			3.0 to 3.6	2.0	–	–	ns
t _h	hold time Dn to CP	Fig.9	1.2	–	–	–	ns
			2.7	1.5	–	–	ns
			3.0 to 3.6	1.5	–	–	ns
f _{max}	maximum clock frequency	Fig.7	1.2	–	–	–	MHz
			2.7	64	–	–	MHz
			3.0 to 3.6	80	–	–	MHz
t _{sk(0)}	skew	note 2	3.0 to 3.6	–	–	1.5	ns

Notes

- All typical values are measured at V_{CC} = 3.3 V and T_{amb} = 25 °C.
- Skew between any two outputs of the same package switching in the same direction. This parameter is guaranteed by design.

勝特力材料 886-3-5753170
 勝特力电子(上海) 86-21-54151736
 勝特力电子(深圳) 86-755-83298787
[Http://www.100y.com.tw](http://www.100y.com.tw)

Octal D-type flip-flop with 5 V tolerant inputs/outputs;
positive edge-trigger; 3-state

74LVC374A

AC WAVEFORMS

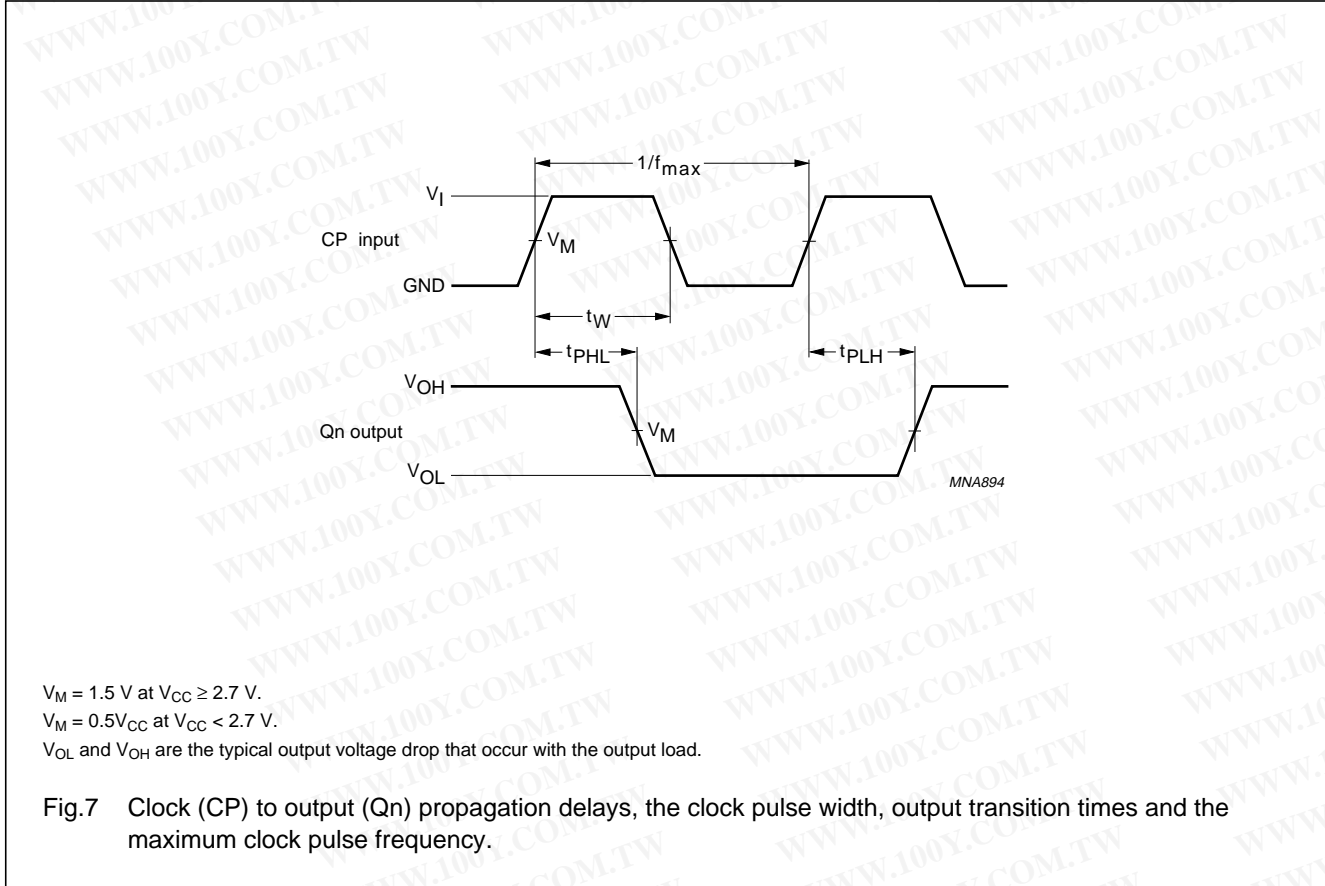

勝特力材料 886-3-5753170
 勝特力电子(上海) 86-21-54151736
 勝特力电子(深圳) 86-755-83298787
[Http://www.100y.com.tw](http://www.100y.com.tw)

Octal D-type flip-flop with 5 V tolerant inputs/outputs;
positive edge-trigger; 3-state

74LVC374A

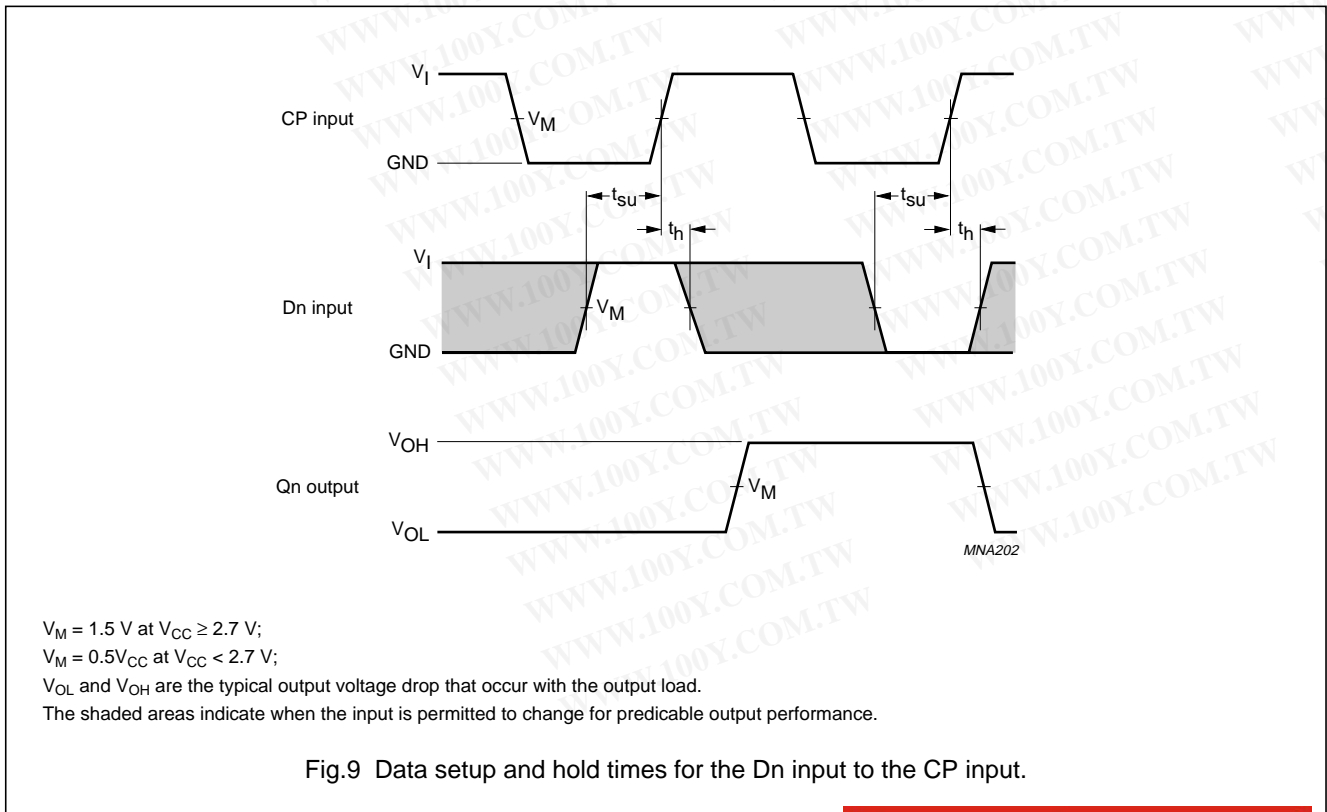
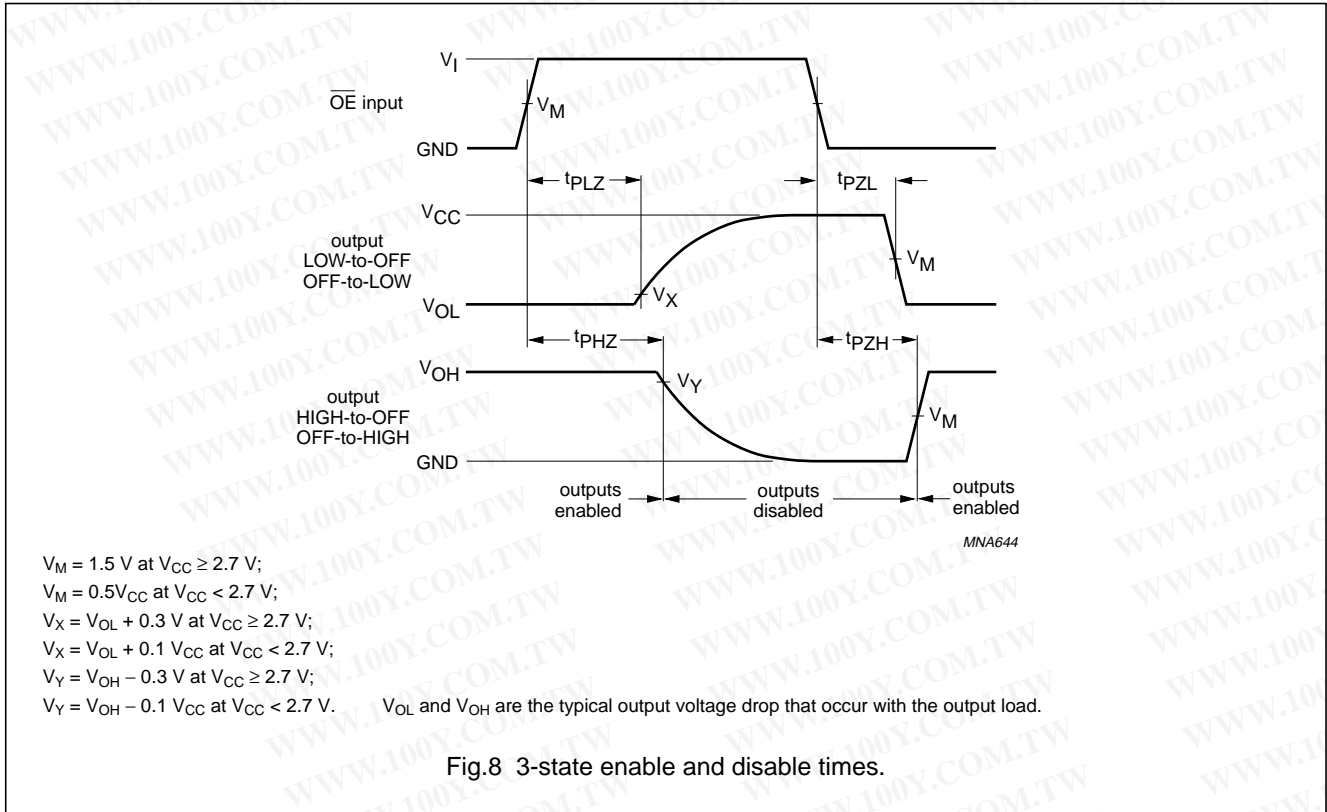

勝特力材料 886-3-5753170
 勝特力电子(上海) 86-21-54151736
 勝特力电子(深圳) 86-755-83298787
[Http://www.100y.com.tw](http://www.100y.com.tw)

Octal D-type flip-flop with 5 V tolerant inputs/outputs;
positive edge-trigger; 3-state

74LVC374A

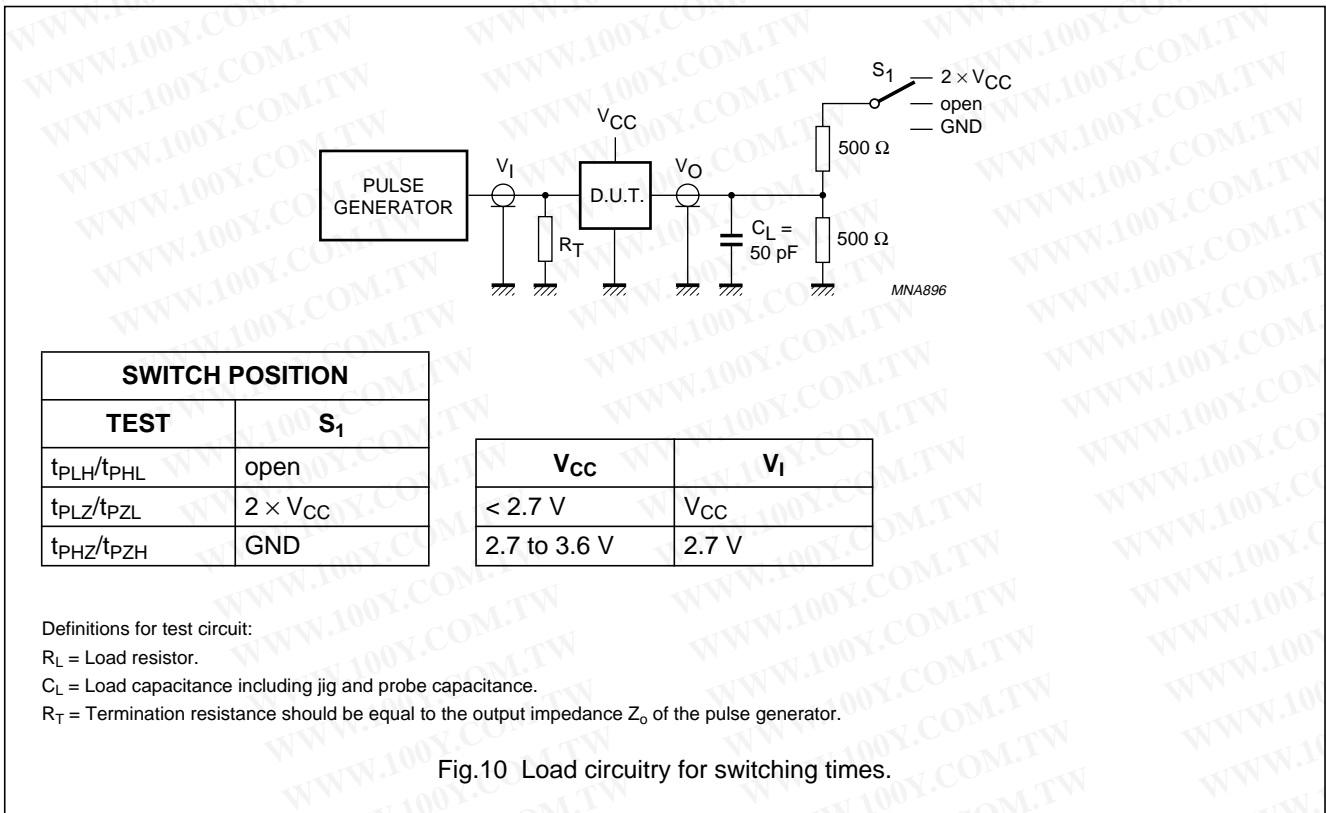

勝特力材料 886-3-5753170
 勝特力电子(上海) 86-21-54151736
 勝特力电子(深圳) 86-755-83298787
[Http://www.100y.com.tw](http://www.100y.com.tw)

Octal D-type flip-flop with 5 V tolerant inputs/outputs;
positive edge-trigger; 3-state

74LVC374A

PACKAGE OUTLINES

S020: plastic small outline package; 20 leads; body width 7.5 mm

SOT163-1

勝特力材料 886-3-5753170
 勝特力电子(上海) 86-21-54151736
 勝特力电子(深圳) 86-755-83298787
[Http://www.100y.com.tw](http://www.100y.com.tw)

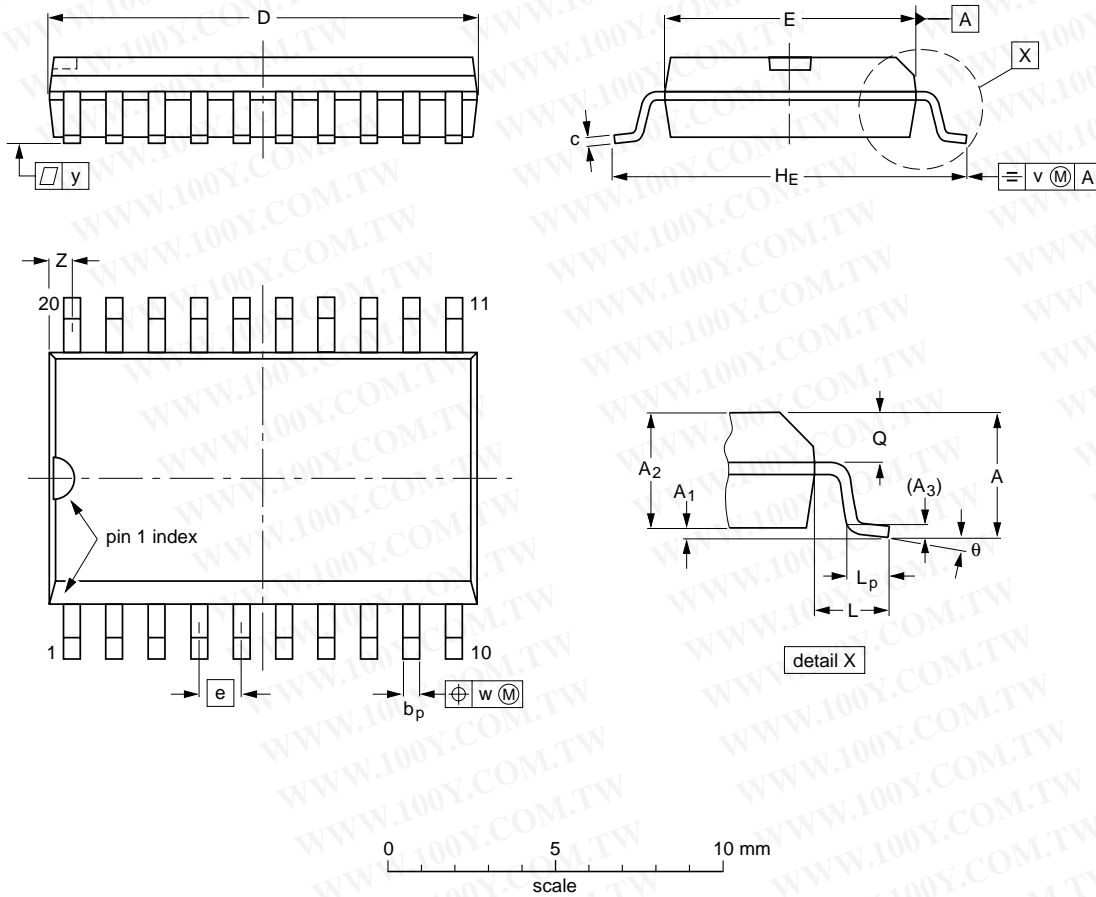

DIMENSIONS (inch dimensions are derived from the original mm dimensions)

UNIT	A max.	A ₁	A ₂	A ₃	b _p	c	D ⁽¹⁾	E ⁽¹⁾	e	H _E	L	L _p	Q	v	w	y	Z ⁽¹⁾	θ
mm	2.65	0.3 0.1	2.45 2.25	0.25	0.49 0.36	0.32 0.23	13.0 12.6	7.6 7.4	1.27	10.65 10.00	1.4	1.1 0.4	1.1 1.0	0.25	0.25	0.1	0.9 0.4	8° 0°
inches	0.1	0.012 0.004	0.096 0.089	0.01	0.019 0.014	0.013 0.009	0.51 0.49	0.30 0.29	0.05	0.419 0.394	0.055	0.043 0.016	0.043 0.039	0.01	0.01	0.004	0.035 0.016	

Note

1. Plastic or metal protrusions of 0.15 mm (0.006 inch) maximum per side are not included.

OUTLINE VERSION	REFERENCES			EUROPEAN PROJECTION	ISSUE DATE
	IEC	JEDEC	JEITA		
SOT163-1	075E04	MS-013			99-12-27 03-02-19

Octal D-type flip-flop with 5 V tolerant inputs/outputs;
positive edge-trigger; 3-state

74LVC374A

SSOP20: plastic shrink small outline package; 20 leads; body width 5.3 mm

SOT339-1

勝特力材料 886-3-5753170
 勝特力电子(上海) 86-21-54151736
 勝特力电子(深圳) 86-755-83298787
[Http://www.100y.com.tw](http://www.100y.com.tw)

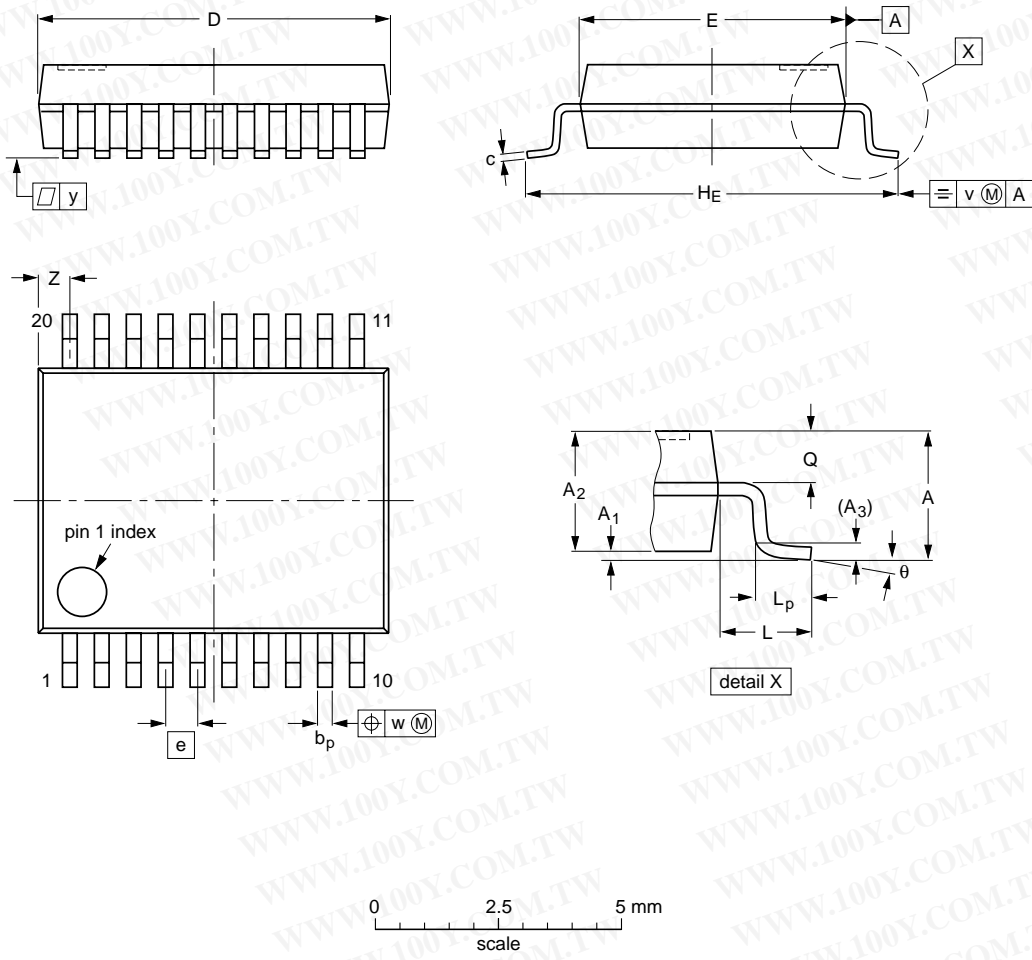

DIMENSIONS (mm are the original dimensions)

UNIT	A max.	A ₁	A ₂	A ₃	b _p	c	D ⁽¹⁾	E ⁽¹⁾	e	H _E	L	L _p	Q	v	w	y	Z ⁽¹⁾	θ
mm	2	0.21 0.05	1.80 1.65	0.25	0.38 0.25	0.20 0.09	7.4 7.0	5.4 5.2	0.65	7.9 7.6	1.25	1.03 0.63	0.9 0.7	0.2	0.13	0.1	0.9 0.5	8° 0°

Note

1. Plastic or metal protrusions of 0.2 mm maximum per side are not included.

OUTLINE VERSION	REFERENCES			EUROPEAN PROJECTION	ISSUE DATE
	IEC	JEDEC	JEITA		
SOT339-1		MO-150			99-12-27 03-02-19

Octal D-type flip-flop with 5 V tolerant inputs/outputs;
positive edge-trigger; 3-state

74LVC374A

TSSOP20: plastic thin shrink small outline package; 20 leads; body width 4.4 mm

SOT360-1

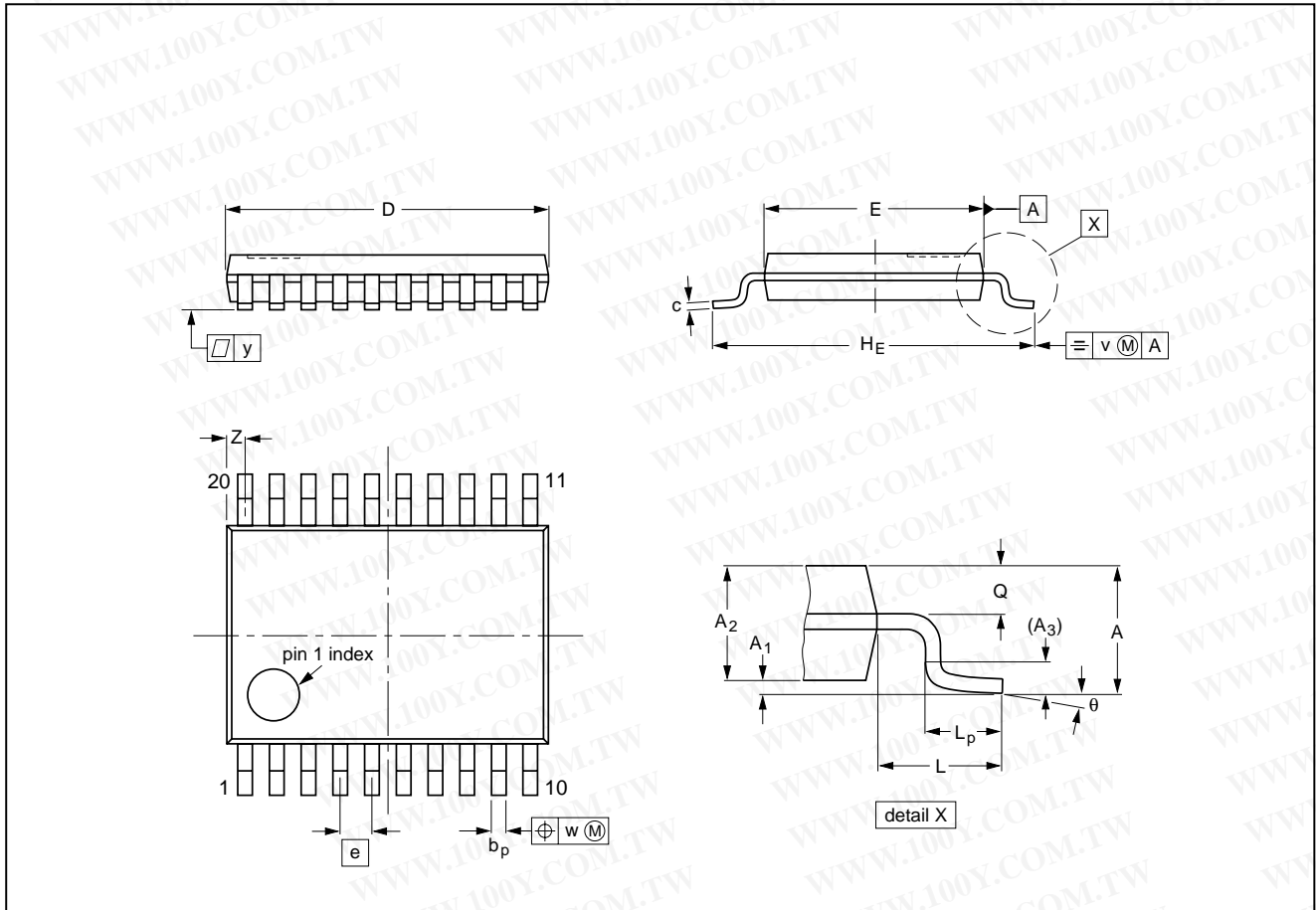

勝特力材料 886-3-5753170
 勝特力电子(上海) 86-21-54151736
 勝特力电子(深圳) 86-755-83298787
[Http://www.100y.com.tw](http://www.100y.com.tw)

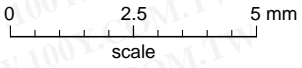

DIMENSIONS (mm are the original dimensions)

UNIT	A max.	A ₁	A ₂	A ₃	b _p	c	D ⁽¹⁾	E ⁽²⁾	e	H _E	L	L _p	Q	v	w	y	z ⁽¹⁾	θ
mm	1.1	0.15 0.05	0.95 0.80	0.25	0.30 0.19	0.2 0.1	6.6 6.4	4.5 4.3	0.65	6.6 6.2	1	0.75 0.50	0.4 0.3	0.2	0.13	0.1	0.5 0.2	8° 0°

Notes

1. Plastic or metal protrusions of 0.15 mm maximum per side are not included.
2. Plastic interlead protrusions of 0.25 mm maximum per side are not included.

OUTLINE VERSION	REFERENCES			EUROPEAN PROJECTION	ISSUE DATE
	IEC	JEDEC	JEITA		
SOT360-1		MO-153			99-12-27 03-02-19

Octal D-type flip-flop with 5 V tolerant inputs/outputs;
positive edge-trigger; 3-state

74LVC374A

DHVQFN20: plastic dual in-line compatible thermal enhanced very thin quad flat package; no leads;
20 terminals; body 2.5 x 4.5 x 0.85 mm

SOT764-1

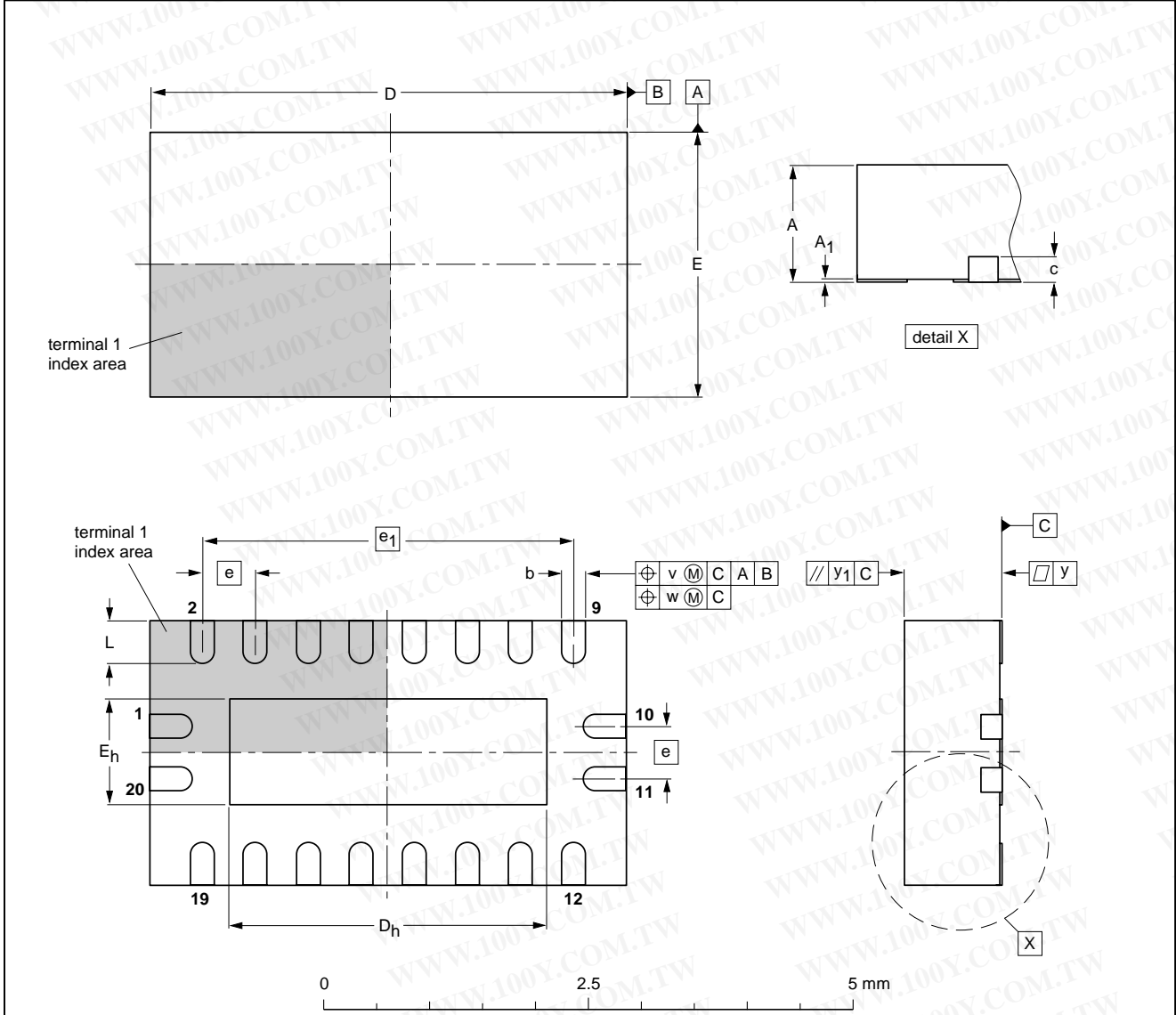

DIMENSIONS (mm are the original dimensions)

UNIT	A ⁽¹⁾ max.	A ₁	b	c	D ⁽¹⁾	D _h	E ⁽¹⁾	E _h	e	e ₁	L	v	w	y	y ₁
mm	1	0.05 0.00	0.30 0.18	0.2	4.6 4.4	3.15 2.85	2.6 2.4	1.15 0.85	0.5	3.5	0.5 0.3	0.1	0.05	0.05	0.1

Note

1. Plastic or metal protrusions of 0.075 mm maximum per side are not included.

OUTLINE VERSION	REFERENCES			EUROPEAN PROJECTION	ISSUE DATE
	IEC	JEDEC	JEITA		
SOT764-1	---	MO-241	---		02-10-17 03-01-27

勝特力材料 886-3-5753170
 勝特力电子(上海) 86-21-54151736
 勝特力电子(深圳) 86-755-83298787
[Http://www.100y.com.tw](http://www.100y.com.tw)

Octal D-type flip-flop with 5 V tolerant inputs/outputs; positive edge-trigger; 3-state

74LVC374A

SOLDERING

Introduction to soldering surface mount packages

This text gives a very brief insight to a complex technology. A more in-depth account of soldering ICs can be found in our "Data Handbook IC26; Integrated Circuit Packages" (document order number 9398 652 90011).

There is no soldering method that is ideal for all surface mount IC packages. Wave soldering can still be used for certain surface mount ICs, but it is not suitable for fine pitch SMDs. In these situations reflow soldering is recommended.

Reflow soldering

Reflow soldering requires solder paste (a suspension of fine solder particles, flux and binding agent) to be applied to the printed-circuit board by screen printing, stencilling or pressure-syringe dispensing before package placement.

Several methods exist for reflowing; for example, convection or convection/infrared heating in a conveyor type oven. Throughput times (preheating, soldering and cooling) vary between 100 and 200 seconds depending on heating method.

Typical reflow peak temperatures range from 215 to 250 °C. The top-surface temperature of the packages should preferably be kept:

- below 220 °C for all the BGA packages and packages with a thickness ≥ 2.5 mm and packages with a thickness < 2.5 mm and a volume ≥ 350 mm³ so called thick/large packages
- below 235 °C for packages with a thickness < 2.5 mm and a volume < 350 mm³ so called small/thin packages.

Wave soldering

Conventional single wave soldering is not recommended for surface mount devices (SMDs) or printed-circuit boards with a high component density, as solder bridging and non-wetting can present major problems.

To overcome these problems the double-wave soldering method was specifically developed.

If wave soldering is used the following conditions must be observed for optimal results:

- Use a double-wave soldering method comprising a turbulent wave with high upward pressure followed by a smooth laminar wave.
- For packages with leads on two sides and a pitch (e):
 - larger than or equal to 1.27 mm, the footprint longitudinal axis is **preferred** to be parallel to the transport direction of the printed-circuit board;
 - smaller than 1.27 mm, the footprint longitudinal axis **must** be parallel to the transport direction of the printed-circuit board.

The footprint must incorporate solder thieves at the downstream end.

- For packages with leads on four sides, the footprint must be placed at a 45° angle to the transport direction of the printed-circuit board. The footprint must incorporate solder thieves downstream and at the side corners.

During placement and before soldering, the package must be fixed with a droplet of adhesive. The adhesive can be applied by screen printing, pin transfer or syringe dispensing. The package can be soldered after the adhesive is cured.

Typical dwell time is 4 seconds at 250 °C.

A mildly-activated flux will eliminate the need for removal of corrosive residues in most applications.

Manual soldering

Fix the component by first soldering two diagonally-opposite end leads. Use a low voltage (24 V or less) soldering iron applied to the flat part of the lead. Contact time must be limited to 10 seconds at up to 300 °C.

When using a dedicated tool, all other leads can be soldered in one operation within 2 to 5 seconds between 270 and 320 °C.

勝特力材料 886-3-5753170
 勝特力电子(上海) 86-21-54151736
 勝特力电子(深圳) 86-755-83298787
[Http://www.100y.com.tw](http://www.100y.com.tw)

Octal D-type flip-flop with 5 V tolerant inputs/outputs; positive edge-trigger; 3-state

74LVC374A

Suitability of surface mount IC packages for wave and reflow soldering methods

PACKAGE ⁽¹⁾	SOLDERING METHOD	
	WAVE	REFLOW ⁽²⁾
BGA, LBGA, LFBGA, SQFP, TFBGA, VFBGA	not suitable	suitable
DHVQFN, HBCC, HBGA, HLQFP, HSQFP, HSOP, HTQFP, HTSSOP, HVQFN, HVSON, SMS	not suitable ⁽³⁾	suitable
PLCC ⁽⁴⁾ , SO, SOJ	suitable	suitable
LQFP, QFP, TQFP	not recommended ⁽⁴⁾⁽⁵⁾	suitable
SSOP, TSSOP, VSO, VSSOP	not recommended ⁽⁶⁾	suitable

Notes

- For more detailed information on the BGA packages refer to the “(LF)BGA Application Note” (AN01026); order a copy from your Philips Semiconductors sales office.
- All surface mount (SMD) packages are moisture sensitive. Depending upon the moisture content, the maximum temperature (with respect to time) and body size of the package, there is a risk that internal or external package cracks may occur due to vaporization of the moisture in them (the so called popcorn effect). For details, refer to the Drypack information in the “Data Handbook IC26; Integrated Circuit Packages; Section: Packing Methods”.
- These packages are not suitable for wave soldering. On versions with the heatsink on the bottom side, the solder cannot penetrate between the printed-circuit board and the heatsink. On versions with the heatsink on the top side, the solder might be deposited on the heatsink surface.
- If wave soldering is considered, then the package must be placed at a 45° angle to the solder wave direction. The package footprint must incorporate solder thieves downstream and at the side corners.
- Wave soldering is suitable for LQFP, TQFP and QFP packages with a pitch (e) larger than 0.8 mm; it is definitely not suitable for packages with a pitch (e) equal to or smaller than 0.65 mm.
- Wave soldering is suitable for SSOP, TSSOP, VSO and VSSOP packages with a pitch (e) equal to or larger than 0.65 mm; it is definitely not suitable for packages with a pitch (e) equal to or smaller than 0.5 mm.

勝特力材料 886-3-5753170
 勝特力电子(上海) 86-21-54151736
 勝特力电子(深圳) 86-755-83298787
[Http://www.100y.com.tw](http://www.100y.com.tw)

Octal D-type flip-flop with 5 V tolerant inputs/outputs; positive edge-trigger; 3-state

74LVC374A

DATA SHEET STATUS

LEVEL	DATA SHEET STATUS ⁽¹⁾	PRODUCT STATUS ⁽²⁾⁽³⁾	DEFINITION
I	Objective data	Development	This data sheet contains data from the objective specification for product development. Philips Semiconductors reserves the right to change the specification in any manner without notice.
II	Preliminary data	Qualification	This data sheet contains data from the preliminary specification. Supplementary data will be published at a later date. Philips Semiconductors reserves the right to change the specification without notice, in order to improve the design and supply the best possible product.
III	Product data	Production	This data sheet contains data from the product specification. Philips Semiconductors reserves the right to make changes at any time in order to improve the design, manufacturing and supply. Relevant changes will be communicated via a Customer Product/Process Change Notification (CPCN).

Notes

1. Please consult the most recently issued data sheet before initiating or completing a design.
2. The product status of the device(s) described in this data sheet may have changed since this data sheet was published. The latest information is available on the Internet at URL <http://www.semiconductors.philips.com>.
3. For data sheets describing multiple type numbers, the highest-level product status determines the data sheet status.

DEFINITIONS

Short-form specification — The data in a short-form specification is extracted from a full data sheet with the same type number and title. For detailed information see the relevant data sheet or data handbook.

Limiting values definition — Limiting values given are in accordance with the Absolute Maximum Rating System (IEC 60134). Stress above one or more of the limiting values may cause permanent damage to the device. These are stress ratings only and operation of the device at these or at any other conditions above those given in the Characteristics sections of the specification is not implied. Exposure to limiting values for extended periods may affect device reliability.

Application information — Applications that are described herein for any of these products are for illustrative purposes only. Philips Semiconductors make no representation or warranty that such applications will be suitable for the specified use without further testing or modification.

DISCLAIMERS

Life support applications — These products are not designed for use in life support appliances, devices, or systems where malfunction of these products can reasonably be expected to result in personal injury. Philips Semiconductors customers using or selling these products for use in such applications do so at their own risk and agree to fully indemnify Philips Semiconductors for any damages resulting from such application.

Right to make changes — Philips Semiconductors reserves the right to make changes in the products - including circuits, standard cells, and/or software - described or contained herein in order to improve design and/or performance. When the product is in full production (status 'Production'), relevant changes will be communicated via a Customer Product/Process Change Notification (CPCN). Philips Semiconductors assumes no responsibility or liability for the use of any of these products, conveys no licence or title under any patent, copyright, or mask work right to these products, and makes no representations or warranties that these products are free from patent, copyright, or mask work right infringement, unless otherwise specified.

勝特力材料 886-3-5753170
 勝特力电子(上海) 86-21-54151736
 勝特力电子(深圳) 86-755-83298787
[Http://www.100y.com.tw](http://www.100y.com.tw)