

# Hi-Reliability NPN Silicon Phototransistor

## Types OP803TX/TXV, OP804TX/TXV, OP805TX/TXV

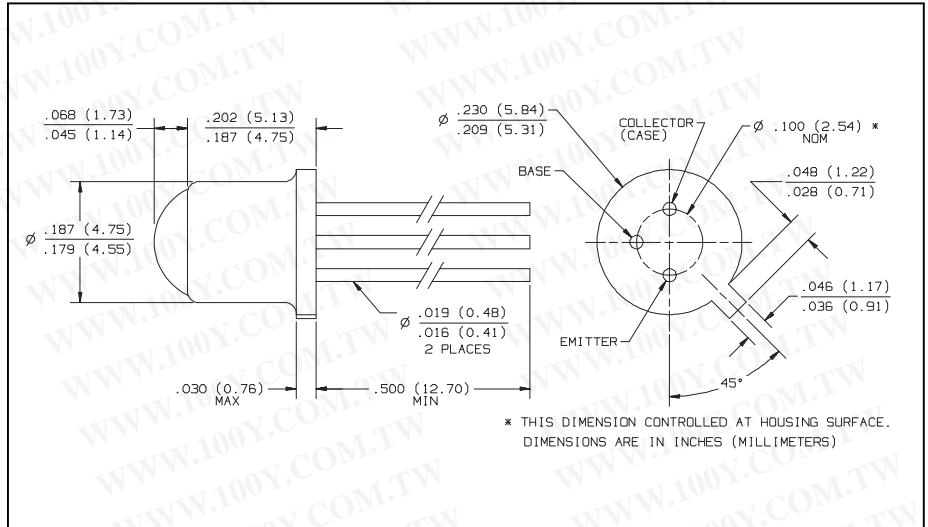

### Features

- High reliability screening patterned after MIL-PRF-19500
- Each lot subjected to Group A & B Lot Acceptance
- Lensed for high sensitivity
- Mechanically and spectrally matched to the OP235TX/TXV and OP236TX/TXV series IREDs

### Description

Each device in the OP803, OP804 and OP805TX/TXV series consists of a high reliability NPN phototransistor mounted in a lensed, hermetically sealed, TO-18 package. All devices are 100% screened per Table II of MIL-PRF-19500. Typical screening and lot acceptance tests are provided on page 13-4.

The OP803, OP804 and OP805 TX/TXV series lensing creates an acceptance half angle of  $12^{\circ}$  measured from the optical axis to the half power point. The series can be matched with either a solid state infrared source, such as the OP235 and OP236 TX/TXV series IREDs, or can be used to sense infrared content in a visible light source, such as a tungsten bulb or sunlight for automatic brightness control.

### Absolute Maximum Ratings ( $T_A = 25^{\circ} \text{C}$ unless otherwise noted)

Storage Temperature Range	-65 $^{\circ}$ C to +150 $^{\circ}$ C
Operating Temperature Range	-55 $^{\circ}$ C to +125 $^{\circ}$ C
Lead Soldering Temperature [1/16 inch (1.6 mm) from case for 5 sec. with soldering iron]	240 $^{\circ}$ C <sup>(1)</sup>
Collector-Emitter Voltage	30 V
Collector-Base Voltage	30 V
Emitter-Base Voltage	5.0 V
Emitter-Collector Voltage	5.0 V
Power Dissipation	250 mW <sup>(2)</sup>

#### Notes:

- (1) RMA flux is recommended. Duration can be extended to 10 sec. max. when flow soldering.  
 (2) Derate linearly 2.5 mW/ $^{\circ}$  C above 25 $^{\circ}$  C.

# Types OP803TX/TXV, OP804TX/TXV, OP805TX/TXV

Electrical Characteristics ( $T_A = 25^\circ\text{C}$  unless otherwise noted)

Symbol	Parameter	Min	Typ	Max	Units	Test Conditions
$I_{C(on)}$	On-State Collector Current					
	OP803TX, TXV	4.0		8.0	mA	$V_{CE} = 5.0\text{ V}, E_e = 5.0\text{ mW/cm}^{2(3)}$
	OP804TX, TXV	7.0		22.0	mA	$V_{CE} = 5.0\text{ V}, E_e = 5.0\text{ mW/cm}^{2(3)}$
	OP805TX, TXV	15.0			mA	$V_{CE} = 5.0\text{ V}, E_e = 5.0\text{ mW/cm}^{2(3)}$
$I_{CEO}$	Collector-Emitter Dark Current			100 100	nA $\mu\text{A}$	$V_{CE} = 10.0\text{ V}, E_e = 0$ $V_{CE} = 10.0\text{ V}, E_e = 0, T_A = 100^\circ\text{C}$
$V_{(BR)CBO}$	Collector-Base Breakdown Voltage	30			V	$I_C = 100\text{ }\mu\text{A}, I_E = 0, E_e = 0$
$V_{(BR)CEO}$	Collector-Emitter Breakdown Voltage	30			V	$I_C = 100\text{ }\mu\text{A}, I_B = 0, E_e = 0$
$V_{(BR)EBO}$	Emitter-Base Breakdown Voltage	5.0			V	$I_E = 100\text{ }\mu\text{A}, I_C = 0, E_e = 0$
$V_{CE(SAT)}$	Collector-Emitter Saturation Voltage			0.40	V	$I_C = 0.4\text{ mA}, E_e = 5.0\text{ mW/cm}^{2(3)}$
$t_r$	Rise Time OP804TX, TXV OP805TX, TXV			10.0 15.0	$\mu\text{s}$	$V_{CC} = 30\text{ V}, I_C = 1.00\text{ mA},$ $R_L = 100\text{ }\Omega$
				10.0 15.0		
$t_f$	Fall Time OP804TX, TXV OP805TX, TXV			10.0 15.0	$\mu\text{s}$	
				10.0 15.0		

(3) Light source is an unfiltered tungsten lamp operated at a temperature of 2870 K.

HI-RELIABLE OPTO COMPONENTS

**勝特力材料 886-3-5753170**  
**勝特力电子(上海) 86-21-54151736**  
**勝特力电子(深圳) 86-755-83298787**  
[Http://www.100y.com.tw](http://www.100y.com.tw)

@TOPICS =

Optek reserves the right to make changes at any time in order to improve design and to supply the best product possible