

Plastic Point Source Infrared Emitting Diode Type OP265WPS

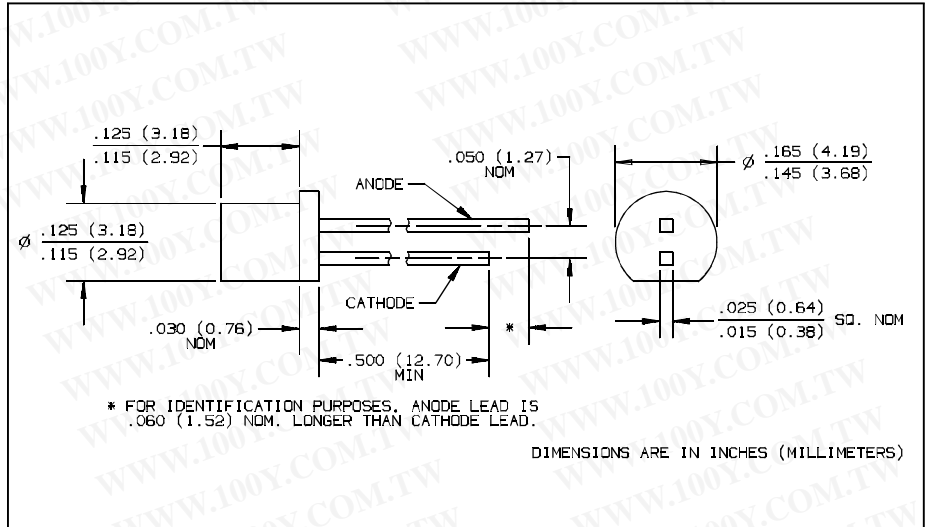

150

Features

- Point source irradiance pattern
- Small package size for space limited applications
- T-1 package style

Description

The OP265WPS is an 850 nm high intensity gallium aluminum arsenide infrared emitting diode molded in an IR transmissive amber-tinted epoxy package. The broad radiation pattern provides relatively even illumination over a large area. The point source GaAlAs IRED emits photons from a 0.004" diameter area centered within the package for precision optical designs. This package is a T-1 style in all respects except for the length of the plastic package.

The stable V_F vs. Temperature characteristic make them ideal for applications where voltage is limited (such as battery operation).

The low t_r/t_f make them ideal for high speed operation.

Absolute Maximum Ratings ($T_A = 25^\circ\text{C}$ unless otherwise noted)

Reverse Voltage	2.0 V
Continuous Forward Current	50 mA
Peak Forward Current (2 μs pulse width, 0.1% duty cycle)	1.0 A
Storage and Operating Temperature Range	-40° C to +100° C
Lead Soldering Temperature [1/16 inch (1.6 mm) from case for 5 sec. with soldering iron]	260° C ⁽¹⁾
Power Dissipation	100 mW ⁽²⁾

NOTES:

- (1) RMA flux is recommended. Duration can be extended to 10 seconds maximum when flow soldering. A maximum of 20 grams force may be applied to the leads when soldering.
- (2) Derate linearly 1.33 mW/ $^\circ\text{C}$ above 25° C.
- (3) $E_{e(\text{APT})}$ is a measurement of the average apertured radiant incidence upon a sensing area 0.081" (2.06 mm) in diameter, perpendicular to and centered on the mechanical axis of the lens, and 0.590" (14.99 mm) from the measurement surface. $E_{e(\text{APT})}$ is not necessarily uniform within the measured area.

Type OP265WPS

Electrical Characteristics ($T_A = 25^\circ\text{C}$ unless otherwise noted)

SYMBOL	PARAMETER	MIN	TYP	MAX	UNITS	TEST CONDITIONS
$E_{e(\text{APT})}$	Apertured Irradiance	.055		.55	mW/cm^2	$I_F = 20\text{ mA}^{(3)}$
V_F	Forward Voltage			1.80	V	$I_F = 20\text{ mA}$
I_R	Reverse Current			20	μA	$V_R = 2\text{ V}$
λ_p	Wavelength at Peak Emission		850		nm	$I_F = 20\text{ mA}$
B	Spectral Bandwidth Between Half Power Points		50		nm	$I_F = 20\text{ mA}$
θ_{HP}	Emission Angle at Half Power		$\pm 60^\circ$		Deg.	$I_F = 20\text{ mA}$
t_r	Rise Time		10		ns	$I_{F(\text{PK})} = 20\text{ mA}$
t_f	Fall Time		10		ns	$\text{PW} = 10\ \mu\text{s}, \text{D.C.} = 10\%$

INFRARED
EMITTING
DIODES

勝特力材料 886-3-5753170
勝特力电子(上海) 86-21-54151736
勝特力电子(深圳) 86-755-83298787
[Http://www.100y.com.tw](http://www.100y.com.tw)