

# SN74LS240 SN74LS244

## Octal Buffer/Line Driver with 3-State Outputs

The SN74LS240 and SN74LS244 are Octal Buffers and Line Drivers designed to be employed as memory address drivers, clock drivers and bus-oriented transmitters/receivers which provide improved PC board density.

- Hysteresis at Inputs to Improve Noise Margins
- 3-State Outputs Drive Bus Lines or Buffer Memory Address Registers
- Input Clamp Diodes Limit High-Speed Termination Effects

### GUARANTEED OPERATING RANGES

Symbol	Parameter	Min	Typ	Max	Unit
V <sub>CC</sub>	Supply Voltage	4.75	5.0	5.25	V
T <sub>A</sub>	Operating Ambient Temperature Range	0	25	70	°C
I <sub>OH</sub>	Output Current – High			–3.0	mA
				–15	mA
I <sub>OL</sub>	Output Current – Low			24	mA

勝特力材料 886-3-5753170  
勝特力电子(上海) 86-21-54151736  
勝特力电子(深圳) 86-755-83298787  
[Http://www.100y.com.tw](http://www.100y.com.tw)



**ON Semiconductor**  
Formerly a Division of Motorola  
<http://onsemi.com>

**LOW  
POWER  
SCHOTTKY**

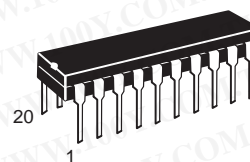

**PLASTIC  
N SUFFIX  
CASE 738**

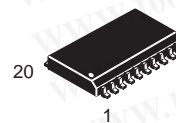

**SOIC  
DW SUFFIX  
CASE 751D**

### ORDERING INFORMATION

Device	Package	Shipping
SN74LS240N	16 Pin DIP	1440 Units/Box
SN74LS240DW	16 Pin	2500/Tape & Reel
SN74LS244N	16 Pin DIP	1440 Units/Box
SN74LS244DW	16 Pin	2500/Tape & Reel

# SN74LS240 SN74LS244

## LOGIC AND CONNECTION DIAGRAMS DIP (TOP VIEW)

### SN74LS240

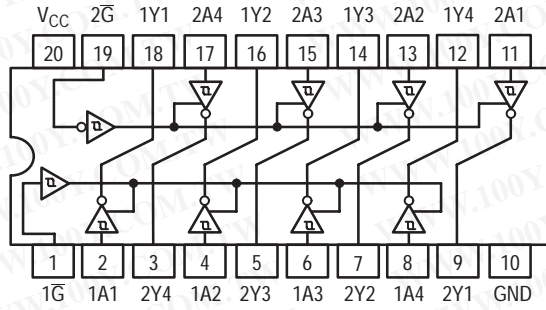

### SN74LS244

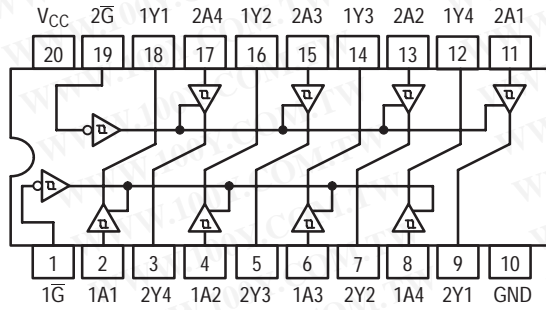

## TRUTH TABLES

### SN74LS240

INPUTS		OUTPUT
1G, 2G	D	
L	L	H
L	H	L
H	X	(Z)

### SN74LS244

INPUTS		OUTPUT
1G, 2G	D	
L	L	L
L	H	H
H	X	(Z)

H = HIGH Voltage Level  
 L = LOW Voltage Level  
 X = Immaterial  
 Z = HIGH Impedance

勝特力材料 886-3-5753170  
 勝特力电子(上海) 86-21-54151736  
 勝特力电子(深圳) 86-755-83298787  
[Http://www.100y.com.tw](http://www.100y.com.tw)

# SN74LS240 SN74LS244

## DC CHARACTERISTICS OVER OPERATING TEMPERATURE RANGE (unless otherwise specified)

Symbol	Parameter	Limits			Unit	Test Conditions
		Min	Typ	Max		
V <sub>IH</sub>	Input HIGH Voltage	2.0			V	Guaranteed Input HIGH Voltage for All Inputs
V <sub>IL</sub>	Input LOW Voltage			0.8	V	Guaranteed Input LOW Voltage for All Inputs
V <sub>T+</sub> -V <sub>T-</sub>	Hysteresis	0.2	0.4		V	V <sub>CC</sub> = MIN
V <sub>IK</sub>	Input Clamp Diode Voltage		-0.65	-1.5	V	V <sub>CC</sub> = MIN, I <sub>IN</sub> = -18 mA
V <sub>OH</sub>	Output HIGH Voltage	2.4	3.4		V	V <sub>CC</sub> = MIN, I <sub>OH</sub> = -3.0 mA
		2.0			V	V <sub>CC</sub> = MIN, I <sub>OH</sub> = MAX
V <sub>OL</sub>	Output LOW Voltage		0.25	0.4	V	I <sub>OL</sub> = 12 mA
			0.35	0.5	V	I <sub>OL</sub> = 24 mA
I <sub>OZH</sub>	Output Off Current HIGH			20	μA	V <sub>CC</sub> = MAX, V <sub>OUT</sub> = 2.7 V
I <sub>OZL</sub>	Output Off Current LOW			-20	μA	V <sub>CC</sub> = MAX, V <sub>OUT</sub> = 0.4 V
I <sub>IH</sub>	Input HIGH Current			20	μA	V <sub>CC</sub> = MAX, V <sub>IN</sub> = 2.7 V
				0.1	mA	V <sub>CC</sub> = MAX, V <sub>IN</sub> = 7.0 V
I <sub>IL</sub>	Input LOW Current			-0.2	mA	V <sub>CC</sub> = MAX, V <sub>IN</sub> = 0.4 V
I <sub>OS</sub>	Output Short Circuit Current (Note 1)	-40		-225	mA	V <sub>CC</sub> = MAX
I <sub>CC</sub>	Power Supply Current Total, Output HIGH			27	mA	V <sub>CC</sub> = MAX
	Total, Output LOW	LS240		44		
		LS244		46		
	Total at HIGH Z	LS240		50		
		LS244		54		

Note 1: Not more than one output should be shorted at a time, nor for more than 1 second.

## AC CHARACTERISTICS (T<sub>A</sub> = 25°C, V<sub>CC</sub> = 5.0 V)

Symbol	Parameter	Limits			Unit	Test Conditions
		Min	Typ	Max		
t <sub>PLH</sub> t <sub>PHL</sub>	Propagation Delay, Data to Output LS240		9.0 12	14 18	ns	C <sub>L</sub> = 45 pF, R <sub>L</sub> = 667 Ω
t <sub>PLH</sub> t <sub>PHL</sub>	Propagation Delay, Data to Output LS244		12 12	18 18	ns	
t <sub>PZH</sub>	Output Enable Time to HIGH Level		15	23	ns	
t <sub>PZL</sub>	Output Enable Time to LOW Level		20	30	ns	
t <sub>PLZ</sub>	Output Disable Time from LOW Level		15	25	ns	C <sub>L</sub> = 5.0 pF, R <sub>L</sub> = 667 Ω
t <sub>PHZ</sub>	Output Disable Time from HIGH Level		10	18	ns	

勝特力材料 886-3-5753170  
 勝特力电子(上海) 86-21-54151736  
 勝特力电子(深圳) 86-755-83298787  
[Http://www.100y.com.tw](http://www.100y.com.tw)

# SN74LS240 SN74LS244

## AC WAVEFORMS

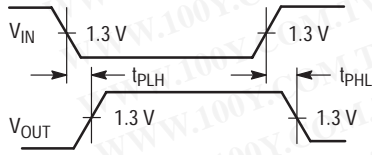

Figure 1.

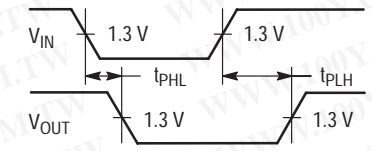

Figure 2.

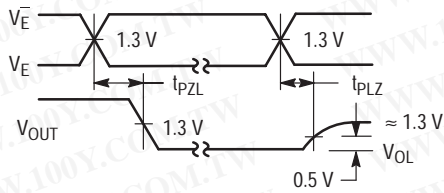

Figure 3.

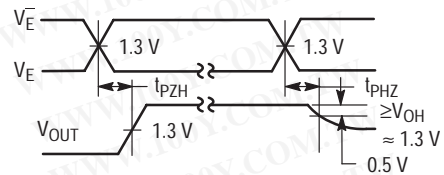
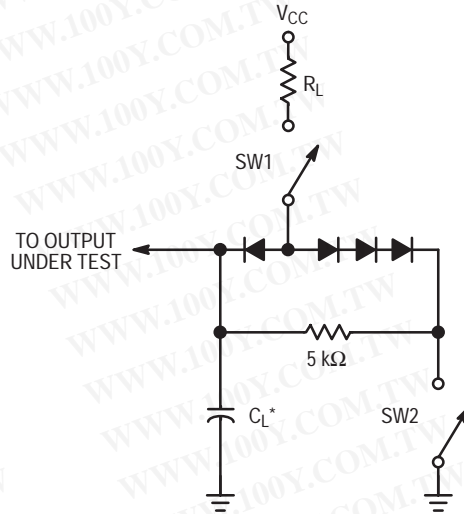

Figure 4.



### SWITCH POSITIONS

SYMBOL	SW1	SW2
$t_{PZH}$	Open	Closed
$t_{PZL}$	Closed	Open
$t_{PLZ}$	Closed	Closed
$t_{PHZ}$	Closed	Closed

Figure 5.

勝特力材料 886-3-5753170  
 勝特力电子(上海) 86-21-54151736  
 勝特力电子(深圳) 86-755-83298787  
[Http://www.100y.com.tw](http://www.100y.com.tw)

# SN74LS240 SN74LS244

## PACKAGE DIMENSIONS

**N SUFFIX**  
**PLASTIC PACKAGE**  
**CASE 738-03**  
**ISSUE E**

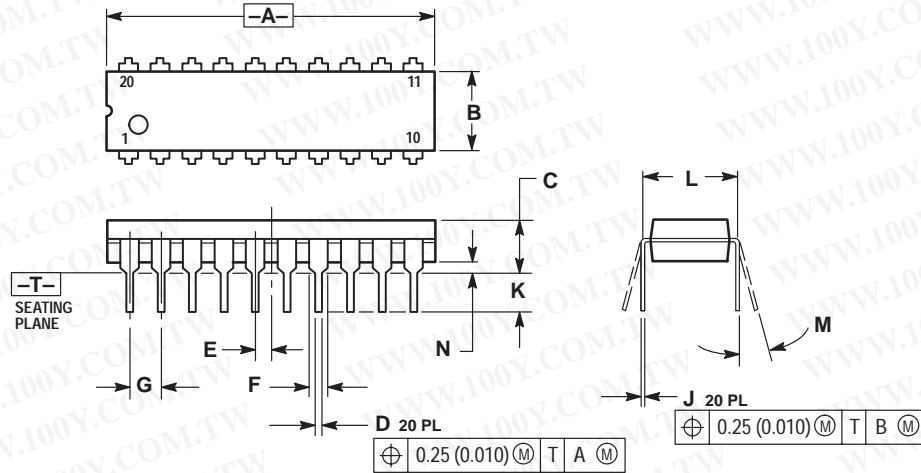

**NOTES:**

1. DIMENSIONING AND TOLERANCING PER ANSI Y14.5M, 1982.
2. CONTROLLING DIMENSION: INCH.
3. DIMENSION L TO CENTER OF LEAD WHEN FORMED PARALLEL.
4. DIMENSION B DOES NOT INCLUDE MOLD FLASH.

DIM	INCHES		MILLIMETERS	
	MIN	MAX	MIN	MAX
A	1.010	1.070	25.66	27.17
B	0.240	0.260	6.10	6.60
C	0.150	0.180	3.81	4.57
D	0.015	0.022	0.39	0.55
E	0.050 BSC		1.27 BSC	
F	0.050	0.070	1.27	1.77
G	0.100 BSC		2.54 BSC	
J	0.008	0.015	0.21	0.38
K	0.110	0.140	2.80	3.55
L	0.300 BSC		7.62 BSC	
M	0°	15°	0°	15°
N	0.020	0.040	0.51	1.01

勝特力材料 886-3-5753170  
 勝特力电子(上海) 86-21-54151736  
 勝特力电子(深圳) 86-755-83298787  
[Http://www.100y.com.tw](http://www.100y.com.tw)

# SN74LS240 SN74LS244

## D SUFFIX PLASTIC SOIC PACKAGE CASE 751D-05 ISSUE F

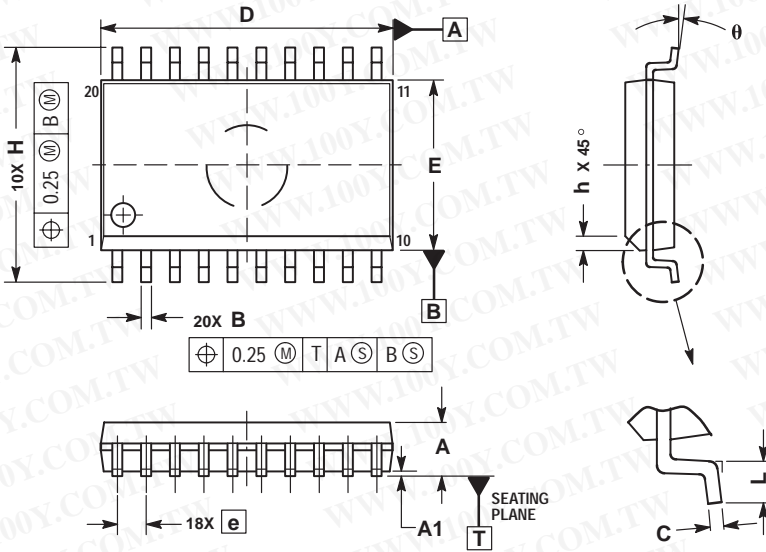

NOTES:

1. DIMENSIONS ARE IN MILLIMETERS.
2. INTERPRET DIMENSIONS AND TOLERANCES PER ASME Y14.5M, 1994.
3. DIMENSIONS D AND E DO NOT INCLUDE MOLD PROTRUSION.
4. MAXIMUM MOLD PROTRUSION 0.15 PER SIDE.
5. DIMENSION B DOES NOT INCLUDE DAMBAR PROTRUSION. ALLOWABLE PROTRUSION SHALL BE 0.13 TOTAL IN EXCESS OF B DIMENSION AT MAXIMUM MATERIAL CONDITION.

MILLIMETERS		
DIM	MIN	MAX
A	2.35	2.65
A1	0.10	0.25
B	0.35	0.49
C	0.23	0.32
D	12.65	12.95
E	7.40	7.60
e	1.27 BSC	
H	10.05	10.55
h	0.25	0.75
L	0.50	0.90
θ	0°	7°

勝特力材料 886-3-5753170  
 勝特力电子(上海) 86-21-54151736  
 勝特力电子(深圳) 86-755-83298787  
[Http://www.100y.com.tw](http://www.100y.com.tw)