

# MC14551B

## Quad 2-Channel Analog Multiplexer/Demultiplexer

The MC14551B is a digitally-controlled analog switch. This device implements a 4PDT solid state switch with low ON impedance and very low OFF Leakage current. Control of analog signals up to the complete supply voltage range can be achieved.

- Triple Diode Protection on All Control Inputs
- Supply Voltage Range = 3.0 Vdc to 18 Vdc
- Analog Voltage Range ( $V_{DD} - V_{EE}$ ) = 3.0 to 18 V  
Note:  $V_{EE}$  must be  $\leq V_{SS}$
- Linearized Transfer Characteristics
- Low Noise —  $12 \text{ nV}/\sqrt{\text{Cycle}}$ ,  $f \geq 1.0 \text{ kHz}$  typical
- For Low  $R_{ON}$ , Use The HC4051, HC4052, or HC4053 High-Speed CMOS Devices
- Switch Function is Break Before Make

### MAXIMUM RATINGS (2.)

Symbol	Parameter	Value	Unit
$V_{DD}$	DC Supply Voltage Range (Referenced to $V_{EE}$ , $V_{SS} \geq V_{EE}$ )	- 0.5 to + 18.0	V
$V_{in}$ , $V_{out}$	Input or Output Voltage (DC or Transient) (Referenced to $V_{SS}$ for Control Input & $V_{EE}$ for Switch I/O)	- 0.5 to $V_{DD} + 0.5$	V
$I_{in}$	Input Current (DC or Transient), per Control Pin	$\pm 10$	mA
$I_{sw}$	Switch Through Current	$\pm 25$	mA
$P_D$	Power Dissipation, per Package (3.)	500	mW
$T_A$	Ambient Temperature Range	- 55 to + 125	$^{\circ}\text{C}$
$T_{stg}$	Storage Temperature Range	- 65 to + 150	$^{\circ}\text{C}$
$T_L$	Lead Temperature (8-Second Soldering)	260	$^{\circ}\text{C}$

2. Maximum Ratings are those values beyond which damage to the device may occur.
3. Temperature Derating:  
Plastic "P and D/DW" Packages: - 7.0 mW/ $^{\circ}\text{C}$  From 65 $^{\circ}\text{C}$  To 125 $^{\circ}\text{C}$

This device contains protection circuitry to guard against damage due to high static voltages or electric fields. However, precautions must be taken to avoid applications of any voltage higher than maximum rated voltages to this high-impedance circuit. For proper operation,  $V_{in}$  and  $V_{out}$  should be constrained to the range  $V_{SS} \leq (V_{in} \text{ or } V_{out}) \leq V_{DD}$  for control inputs and  $V_{EE} \leq (V_{in} \text{ or } V_{out}) \leq V_{DD}$  for Switch I/O.

Unused inputs must always be tied to an appropriate logic voltage level (e.g., either  $V_{SS}$ ,  $V_{EE}$  or  $V_{DD}$ ). Unused outputs must be left open.



ON Semiconductor

<http://onsemi.com>

### MARKING DIAGRAMS

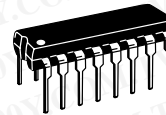

PDIP-16  
P SUFFIX  
CASE 648

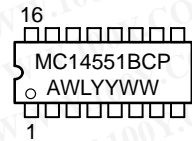

SOIC-16  
D SUFFIX  
CASE 751B

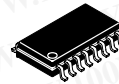
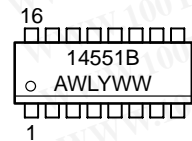

SOEIAJ-16  
F SUFFIX  
CASE 966

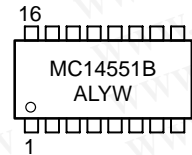

A = Assembly Location  
WL, L = Wafer Lot  
YY, Y = Year  
WW, W = Work Week

### ORDERING INFORMATION

Device	Package	Shipping
MC14551BCP	PDIP-16	2000/Box
MC14551BD	SOIC-16	48/Rail
MC14551BDR2	SOIC-16	2500/Tape & Reel
MC14551BF	SOEIAJ-16	See Note 1.

1. For ordering information on the EIAJ version of the SOIC packages, please contact your local ON Semiconductor representative.

勝特力材料 886-3-5753170  
勝特力电子(上海) 86-21-54151736  
勝特力电子(深圳) 86-755-83298787  
[Http://www.100y.com.tw](http://www.100y.com.tw)

# MC14551B

勝特力材料 886-3-5753170  
 勝特力电子(上海) 86-21-54151736  
 勝特力电子(深圳) 86-755-83298787  
[Http://www.100y.com.tw](http://www.100y.com.tw)

## PIN ASSIGNMENT

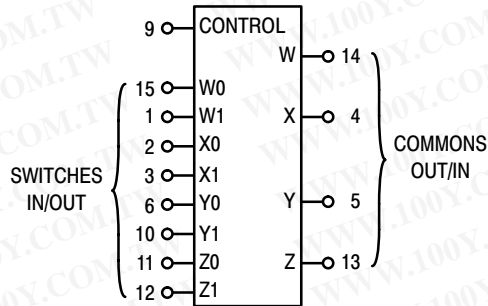
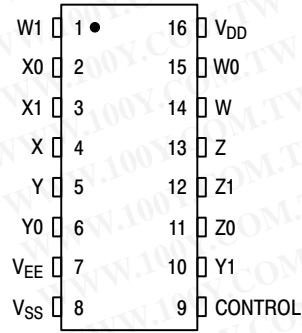

V<sub>DD</sub> = Pin 16  
 V<sub>SS</sub> = Pin 8  
 V<sub>EE</sub> = Pin 7

Control	ON
0	W0 X0 Y0 Z0
1	W1 X1 Y1 Z1

NOTE: Control Input referenced to V<sub>SS</sub>. Analog Inputs and Outputs reference to V<sub>EE</sub>. V<sub>EE</sub> must be ≤ V<sub>SS</sub>.

# MC14551B

勝特力材料 886-3-5753170  
 勝特力电子(上海) 86-21-54151736  
 勝特力电子(深圳) 86-755-83298787  
[Http://www.100y.com.tw](http://www.100y.com.tw)

## ELECTRICAL CHARACTERISTICS

Characteristic	Symbol	V <sub>DD</sub>	Test Conditions	- 55°C		25°C			125°C		Unit
				Min	Max	Min	Typ (4.)	Max	Min	Max	

### SUPPLY REQUIREMENTS (Voltages Referenced to V<sub>EE</sub>)

Power Supply Voltage Range	V <sub>DD</sub>	—	V <sub>DD</sub> - 3.0 ≥ V <sub>SS</sub> ≥ V <sub>EE</sub>	3.0	18	3.0	—	18	3.0	18	V
Quiescent Current Per Package	I <sub>DD</sub>	5.0 10 15	Control Inputs: V <sub>in</sub> = V <sub>SS</sub> or V <sub>DD</sub> , Switch I/O: V <sub>EE</sub> ≤ V <sub>I/O</sub> ≤ V <sub>DD</sub> , and ΔV <sub>switch</sub> ≤ 500 mV (5.)	— — —	5.0 10 20	— — —	0.005 0.010 0.015	5.0 10 20	— — —	150 300 600	μA
Total Supply Current (Dynamic Plus Quiescent, Per Package)	I <sub>D(AV)</sub>	5.0 10 15	T <sub>A</sub> = 25°C only (The channel component, (V <sub>in</sub> - V <sub>out</sub> )/R <sub>on</sub> , is not included.)	Typical (0.07 μA/kHz) f + I <sub>DD</sub> (0.20 μA/kHz) f + I <sub>DD</sub> (0.36 μA/kHz) f + I <sub>DD</sub>							μA

### CONTROL INPUT (Voltages Referenced to V<sub>SS</sub>)

Low-Level Input Voltage	V <sub>IL</sub>	5.0 10 15	R <sub>on</sub> = per spec, I <sub>off</sub> = per spec	— — —	1.5 3.0 4.0	— — —	2.25 4.50 6.75	1.5 3.0 4.0	— — —	1.5 3.0 4.0	V
High-Level Input Voltage	V <sub>IH</sub>	5.0 10 15	R <sub>on</sub> = per spec, I <sub>off</sub> = per spec	3.5 7.0 11	— — —	3.5 7.0 11	2.75 5.50 8.25	— — —	3.5 7.0 11	— — —	V
Input Leakage Current	I <sub>in</sub>	15	V <sub>in</sub> = 0 or V <sub>DD</sub>	—	±0.1	—	±0.00001	±0.1	—	±1.0	μA
Input Capacitance	C <sub>in</sub>	—	—	—	—	—	5.0	7.5	—	—	pF

### SWITCHES IN/OUT AND COMMONS OUT/IN — W, X, Y, Z (Voltages Referenced to V<sub>EE</sub>)

Recommended Peak-to-Peak Voltage Into or Out of the Switch	V <sub>I/O</sub>	—	Channel On or Off	0	V <sub>DD</sub>	0	—	V <sub>DD</sub>	0	V <sub>DD</sub>	V <sub>p-p</sub>
Recommended Static or Dynamic Voltage Across the Switch (5.) (Figure 3)	ΔV <sub>switch</sub>	—	Channel On	0	600	0	—	600	0	300	mV
Output Offset Voltage	V <sub>OO</sub>	—	V <sub>in</sub> = 0 V, No Load	—	—	—	10	—	—	—	μV
ON Resistance	R <sub>on</sub>	5.0 10 15	ΔV <sub>switch</sub> ≤ 500 mV (5.), V <sub>in</sub> = V <sub>IL</sub> or V <sub>IH</sub> (Control), and V <sub>in</sub> = 0 to V <sub>DD</sub> (Switch)	— — —	800 400 220	— — —	250 120 80	1050 500 280	— — —	1200 520 300	Ω
ΔON Resistance Between Any Two Channels in the Same Package	ΔR <sub>on</sub>	5.0 10 15	—	— — —	70 50 45	— — —	25 10 10	70 50 45	— — —	135 95 65	Ω
Off-Channel Leakage Current (Figure 8)	I <sub>off</sub>	15	V <sub>in</sub> = V <sub>IL</sub> or V <sub>IH</sub> (Control) Channel to Channel or Any One Channel	—	±100	—	±0.05	±100	—	±1000	nA
Capacitance, Switch I/O	C <sub>I/O</sub>	—	Switch Off	—	—	—	10	—	—	—	pF
Capacitance, Common O/I	C <sub>O/I</sub>	—	—	—	—	—	17	—	—	—	pF
Capacitance, Feedthrough (Channel Off)	C <sub>I/O</sub>	—	Pins Not Adjacent Pins Adjacent	— —	— —	— —	0.15 0.47	— —	— —	— —	pF

- Data labeled "Typ" is not to be used for design purposes, but is intended as an indication of the IC's potential performance.
- For voltage drops across the switch (ΔV<sub>switch</sub>) > 600 mV (> 300 mV at high temperature), excessive V<sub>DD</sub> current may be drawn; i.e. the current out of the switch may contain both V<sub>DD</sub> and switch input components. The reliability of the device will be unaffected unless the Maximum Ratings are exceeded. (See first page of this data sheet.)

# MC14551B

勝特力材料 886-3-5753170  
 勝特力电子(上海) 86-21-54151736  
 勝特力电子(深圳) 86-755-83298787  
[Http://www.100y.com.tw](http://www.100y.com.tw)

## ELECTRICAL CHARACTERISTICS ( $C_L = 50 \text{ pF}$ , $T_A = 25^\circ\text{C}$ , $V_{EE} \leq V_{SS}$ )

Characteristic	Symbol	$V_{DD} - V_{EE}$ Vdc	Min	Typ (6.)	Max	Unit
Propagation Delay Times Switch Input to Switch Output ( $R_L = 10 \text{ k}\Omega$ ) $t_{PLH}$ , $t_{PHL} = (0.17 \text{ ns/pF}) C_L + 26.5 \text{ ns}$ $t_{PLH}$ , $t_{PHL} = (0.08 \text{ ns/pF}) C_L + 11 \text{ ns}$ $t_{PLH}$ , $t_{PHL} = (0.06 \text{ ns/pF}) C_L + 9.0 \text{ ns}$	$t_{PLH}$ , $t_{PHL}$	5.0 10 15	— — —	35 15 12	90 40 30	ns
Control Input to Output ( $R_L = 10 \text{ k}\Omega$ ) $V_{EE} = V_{SS}$ (Figure 4)	$t_{PLH}$ , $t_{PHL}$	5.0 10 15	— — —	350 140 100	875 350 250	ns
Second Harmonic Distortion $R_L = 10 \text{ k}\Omega$ , $f = 1 \text{ kHz}$ , $V_{in} = 5 V_{p-p}$	—	10	—	0.07	—	%
Bandwidth (Figure 5) $R_L = 1 \text{ k}\Omega$ , $V_{in} = 1/2 (V_{DD} - V_{EE})_{p-p}$ , $20 \text{ Log} (V_{out}/V_{in}) = -3 \text{ dB}$ , $C_L = 50 \text{ pF}$	BW	10	—	17	—	MHz
Off Channel Feedthrough Attenuation, Figure 5 $R_L = 1 \text{ k}\Omega$ , $V_{in} = 1/2 (V_{DD} - V_{EE})_{p-p}$ , $f_{in} = 55 \text{ MHz}$	—	10	—	-50	—	dB
Channel Separation (Figure 6) $R_L = 1 \text{ k}\Omega$ , $V_{in} = 1/2 (V_{DD} - V_{EE})_{p-p}$ , $f_{in} = 3 \text{ MHz}$	—	10	—	-50	—	dB
Crosstalk, Control Input to Common O/I, Figure 7 $R_1 = 1 \text{ k}\Omega$ , $R_L = 10 \text{ k}\Omega$ , Control $t_r = t_f = 20 \text{ ns}$	—	10	—	75	—	mV

6. Data labelled "Typ" is not to be used for design purposes but is intended as an indication of the IC's potential performance.

# MC14551B

勝特力材料 886-3-5753170  
 勝特力电子(上海) 86-21-54151736  
 勝特力电子(深圳) 86-755-83298787  
[Http://www.100y.com.tw](http://www.100y.com.tw)

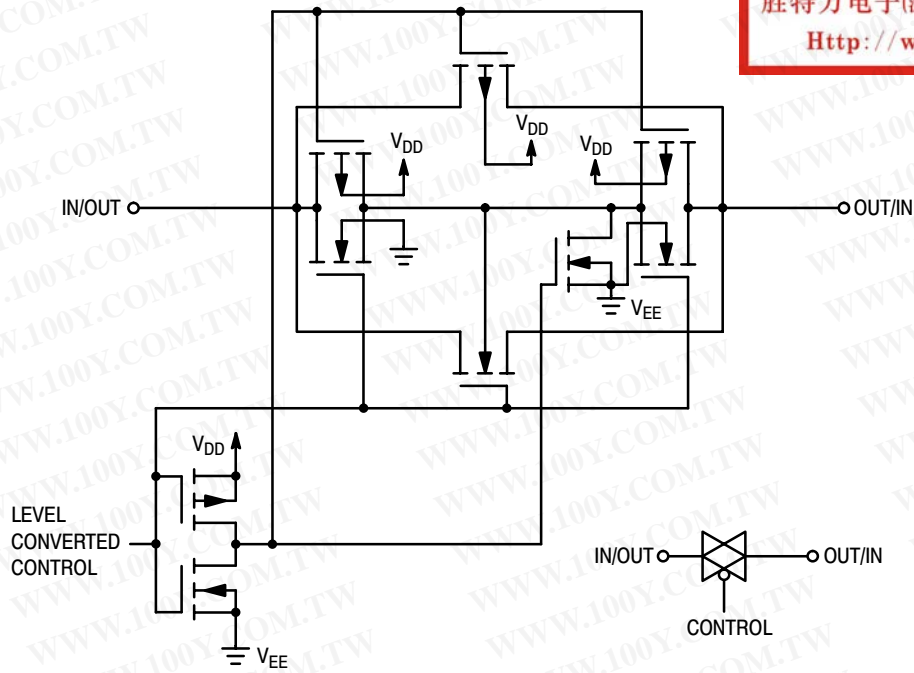

Figure 1. Switch Circuit Schematic

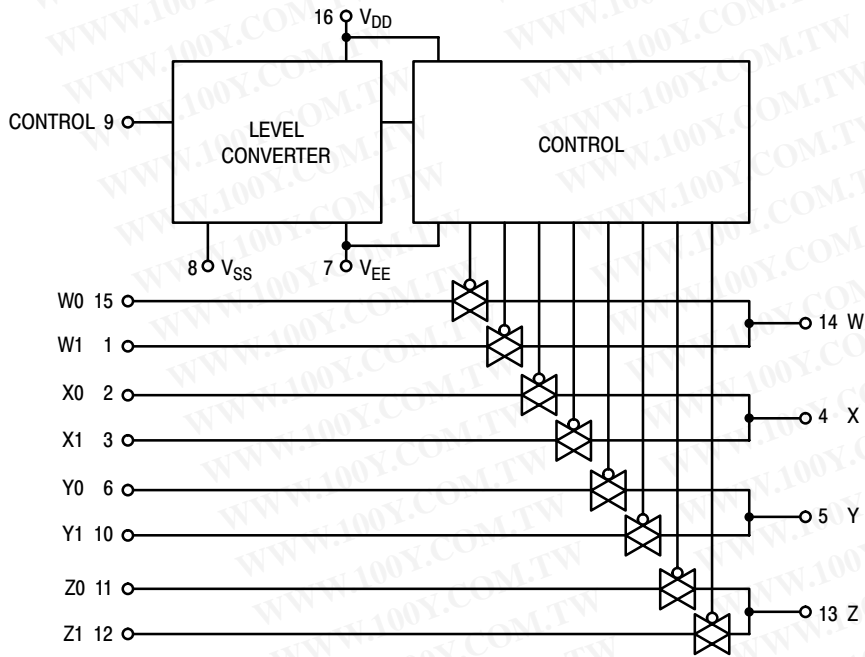

Figure 2. MC14551B Functional Diagram

# MC14551B

## TEST CIRCUITS

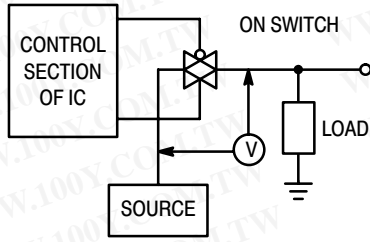

Figure 3.  $\Delta V$  Across Switch

Control input used to turn ON or OFF the switch under test.

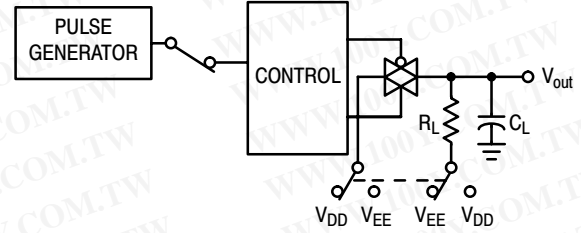

Figure 4. Propagation Delay Times, Control to Output

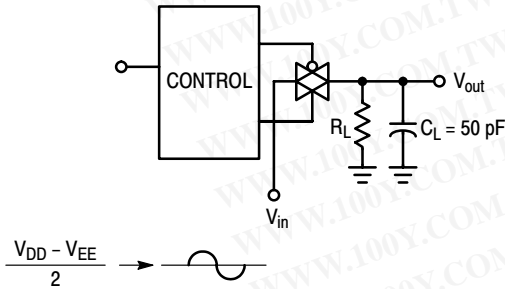

Figure 5. Bandwidth and Off-Channel Feedthrough Attenuation

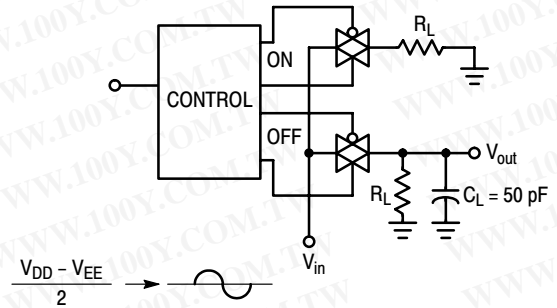

Figure 6. Channel Separation (Adjacent Channels Used for Setup)

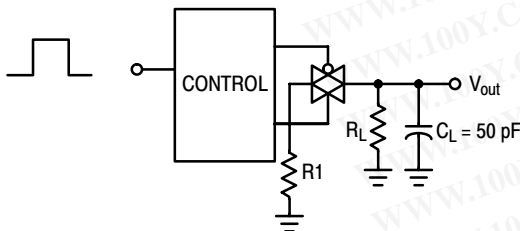

Figure 7. Crosstalk, Control Input to Common O/I

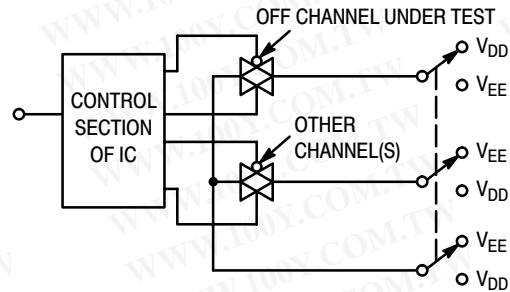

Figure 8. Off Channel Leakage

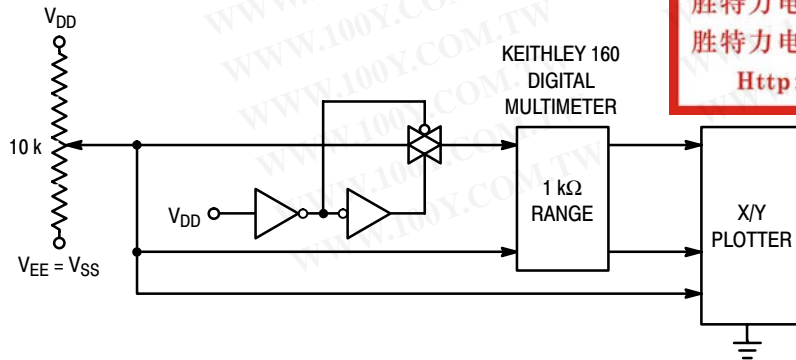

Figure 9. Channel Resistance ( $R_{ON}$ ) Test Circuit

勝特力材料 886-3-5753170  
 勝特力电子(上海) 86-21-54151736  
 勝特力电子(深圳) 86-755-83298787  
[Http://www.100y.com.tw](http://www.100y.com.tw)

TYPICAL RESISTANCE CHARACTERISTICS

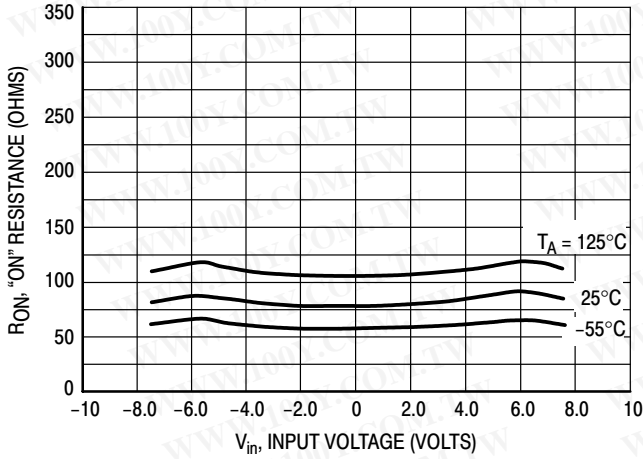

Figure 10.  $V_{DD}$  @ 7.5 V,  $V_{EE}$  @ -7.5 V

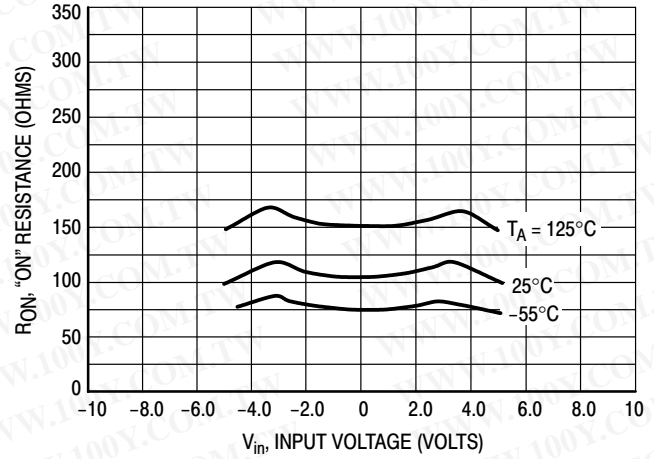

Figure 11.  $V_{DD}$  @ 5.0 V,  $V_{EE}$  @ -5.0 V

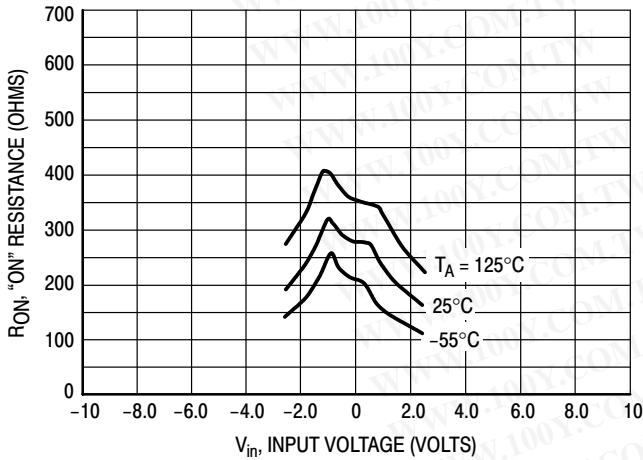

Figure 12.  $V_{DD}$  @ 2.5 V,  $V_{EE}$  @ -2.5 V

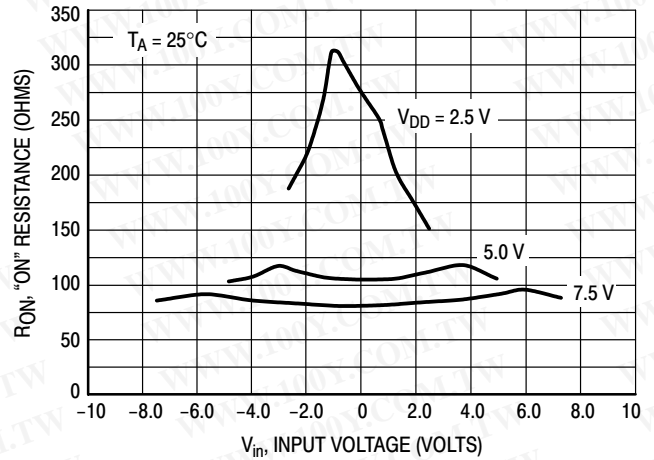

Figure 13. Comparison at  $25^\circ\text{C}$ ,  $V_{DD}$  @ -  $V_{EE}$

# MC14551B

## APPLICATIONS INFORMATION

Figure A illustrates use of the on-chip level converter detailed in Figure 2. The 0-to-5 volt Digital Control signal is used to directly control a 9 V<sub>p-p</sub> analog signal.

The digital control logic levels are determined by V<sub>DD</sub> and V<sub>SS</sub>. The V<sub>DD</sub> voltage is the logic high voltage; the V<sub>SS</sub> voltage is logic low. For the example, V<sub>DD</sub> = +5 V = logic high at the control inputs; V<sub>SS</sub> = GND = 0 V = logic low.

The maximum analog signal level is determined by V<sub>DD</sub> and V<sub>EE</sub>. The V<sub>DD</sub> voltage determines the maximum recommended peak above V<sub>SS</sub>. The V<sub>EE</sub> voltage determines the maximum swing below V<sub>SS</sub>. For the example, V<sub>DD</sub> - V<sub>SS</sub> = 5 volt maximum swing above V<sub>SS</sub>; V<sub>SS</sub> - V<sub>EE</sub> = 5 volt maximum swing below V<sub>SS</sub>. The example shows a ± 4.5 volt signal which allows a 1/2 volt

margin at each peak. If voltage transients above V<sub>DD</sub> and/or below V<sub>EE</sub> are anticipated on the analog channels, external diodes (D<sub>x</sub>) are recommended as shown in Figure B. These diodes should be small signal types able to absorb the maximum anticipated current surges during clipping.

The absolute maximum potential difference between V<sub>DD</sub> and V<sub>EE</sub> is 18.0 volts. Most parameters are specified up to 15 volts which is the recommended maximum difference between V<sub>DD</sub> and V<sub>EE</sub>.

Balanced supplies are not required. However, V<sub>SS</sub> must be greater than or equal to V<sub>EE</sub>. For example, V<sub>DD</sub> = +10 volts, V<sub>SS</sub> = +5 volts, and V<sub>EE</sub> = -3 volts is acceptable. See the table below.

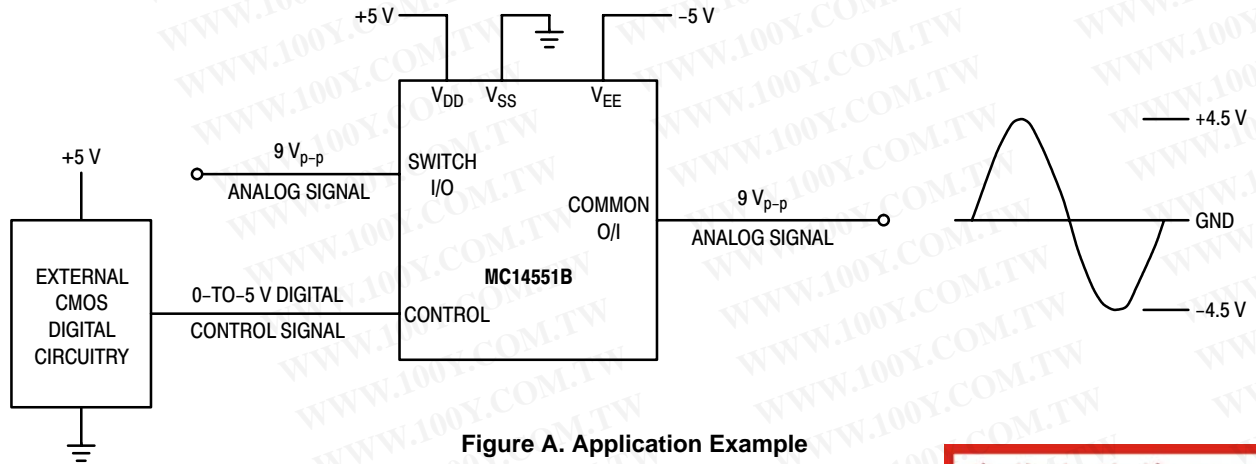

Figure A. Application Example

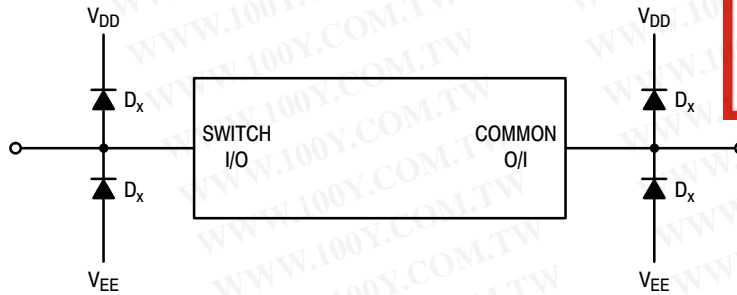

Figure B. External Schottky or Germanium Clipping Diodes

勝特力材料 886-3-5753170  
 勝特力电子(上海) 86-21-54151736  
 勝特力电子(深圳) 86-755-83298787  
[Http://www.100y.com.tw](http://www.100y.com.tw)

### POSSIBLE SUPPLY CONNECTIONS

V <sub>DD</sub> In Volts	V <sub>SS</sub> In Volts	V <sub>EE</sub> In Volts	Control Inputs Logic High/Logic Low In Volts	Maximum Analog Signal Range In Volts
+ 8	0	- 8	+ 8/0	+ 8 to - 8 = 16 V <sub>p-p</sub>
+ 5	0	- 12	+ 5/0	+ 5 to - 12 = 17 V <sub>p-p</sub>
+ 5	0	0	+ 5/0	+ 5 to 0 = 5 V <sub>p-p</sub>
+ 5	0	- 5	+ 5/0	+ 5 to - 5 = 10 V <sub>p-p</sub>
+ 10		- 5	+ 10/ + 5	+ 10 to - 5 = 15 V <sub>p-p</sub>

# MC14551B

## PACKAGE DIMENSIONS

PDIP-16  
P SUFFIX  
CASE 648-08  
ISSUE R

勝特力材料 886-3-5753170  
 勝特力电子(上海) 86-21-54151736  
 勝特力电子(深圳) 86-755-83298787  
[Http://www.100y.com.tw](http://www.100y.com.tw)

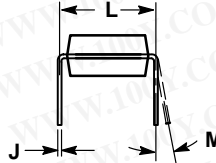
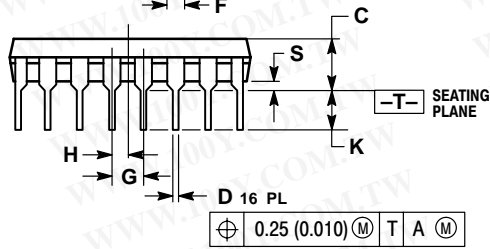
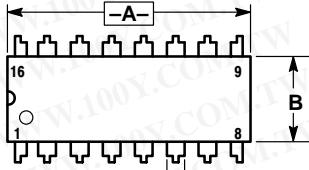

NOTES:

1. DIMENSIONING AND TOLERANCING PER ANSI Y14.5M, 1982.
2. CONTROLLING DIMENSION: INCH.
3. DIMENSION L TO CENTER OF LEADS WHEN FORMED PARALLEL.
4. DIMENSION B DOES NOT INCLUDE MOLD FLASH.
5. ROUNDED CORNERS OPTIONAL.

DIM	INCHES		MILLIMETERS	
	MIN	MAX	MIN	MAX
A	0.740	0.770	18.80	19.55
B	0.250	0.270	6.35	6.85
C	0.145	0.175	3.69	4.44
D	0.015	0.021	0.39	0.53
F	0.040	0.70	1.02	1.77
G	0.100 BSC		2.54 BSC	
H	0.050 BSC		1.27 BSC	
J	0.008	0.015	0.21	0.38
K	0.110	0.130	2.80	3.30
L	0.295	0.305	7.50	7.74
M	0°	10°	0°	10°
S	0.020	0.040	0.51	1.01

⊕	0.25 (0.010)	Ⓜ	T	A	Ⓜ
---	--------------	---	---	---	---

# MC14551B

## PACKAGE DIMENSIONS

SOIC-16  
D SUFFIX  
CASE 751B-05  
ISSUE J

勝特力材料 886-3-5753170  
勝特力电子(上海) 86-21-54151736  
勝特力电子(深圳) 86-755-83298787  
Http://www.100y.com.tw

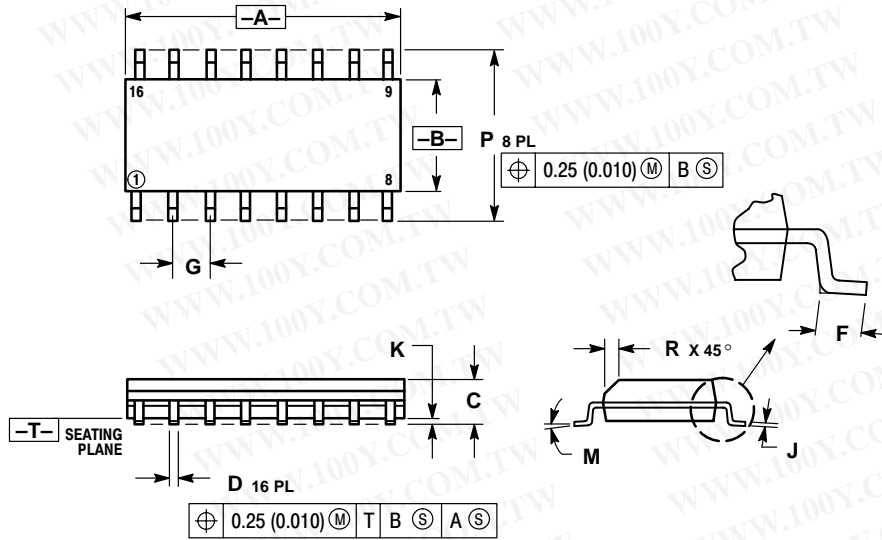

### NOTES:

1. DIMENSIONING AND TOLERANCING PER ANSI Y14.5M, 1982.
2. CONTROLLING DIMENSION: MILLIMETER.
3. DIMENSIONS A AND B DO NOT INCLUDE MOLD PROTRUSION.
4. MAXIMUM MOLD PROTRUSION 0.15 (0.006) PER SIDE.
5. DIMENSION D DOES NOT INCLUDE DAMBAR PROTRUSION. ALLOWABLE DAMBAR PROTRUSION SHALL BE 0.127 (0.005) TOTAL IN EXCESS OF THE D DIMENSION AT MAXIMUM MATERIAL CONDITION.

DIM	MILLIMETERS		INCHES	
	MIN	MAX	MIN	MAX
A	9.80	10.00	0.386	0.393
B	3.80	4.00	0.150	0.157
C	1.35	1.75	0.054	0.068
D	0.35	0.49	0.014	0.019
F	0.40	1.25	0.016	0.049
G	1.27 BSC		0.050 BSC	
J	0.19	0.25	0.008	0.009
K	0.10	0.25	0.004	0.009
M	0°	7°	0°	7°
P	5.80	6.20	0.229	0.244
R	0.25	0.50	0.010	0.019

# MC14551B

## PACKAGE DIMENSIONS

SOEIAJ-16  
F SUFFIX  
PLASTIC EIAJ SOIC PACKAGE  
CASE 966-01  
ISSUE O

勝特力材料 886-3-5753170  
勝特力电子(上海) 86-21-54151736  
勝特力电子(深圳) 86-755-83298787  
Http://www.100y.com.tw

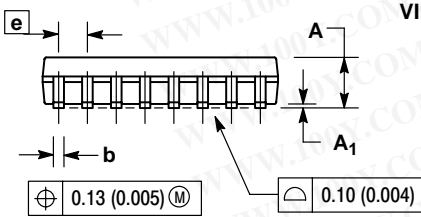
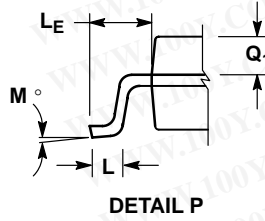
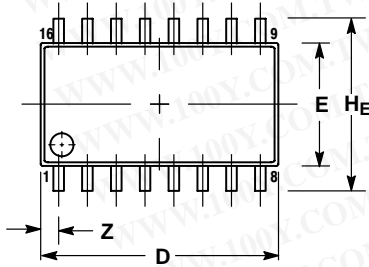

VIEW P

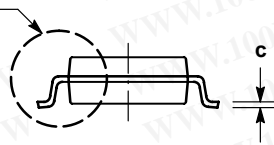

NOTES:

1. DIMENSIONING AND TOLERANCING PER ANSI Y14.5M, 1982.
2. CONTROLLING DIMENSION: MILLIMETER.
3. DIMENSIONS D AND E DO NOT INCLUDE MOLD FLASH OR PROTRUSIONS AND ARE MEASURED AT THE PARTING LINE. MOLD FLASH OR PROTRUSIONS SHALL NOT EXCEED 0.15 (0.006) PER SIDE.
4. TERMINAL NUMBERS ARE SHOWN FOR REFERENCE ONLY.
5. THE LEAD WIDTH DIMENSION (b) DOES NOT INCLUDE DAMBAR PROTRUSION. ALLOWABLE DAMBAR PROTRUSION SHALL BE 0.08 (0.003) TOTAL IN EXCESS OF THE LEAD WIDTH DIMENSION AT MAXIMUM MATERIAL CONDITION. DAMBAR CANNOT BE LOCATED ON THE LOWER RADIUS OR THE FOOT. MINIMUM SPACE BETWEEN PROTRUSIONS AND ADJACENT LEAD TO BE 0.46 (0.018).

DIM	MILLIMETERS		INCHES	
	MIN	MAX	MIN	MAX
A	---	2.05	---	0.081
A <sub>1</sub>	0.05	0.20	0.002	0.008
b	0.35	0.50	0.014	0.020
c	0.18	0.27	0.007	0.011
D	9.90	10.50	0.390	0.413
E	5.10	5.45	0.201	0.215
e	1.27 BSC		0.050 BSC	
HE	7.40	8.20	0.291	0.323
L	0.50	0.85	0.020	0.033
LE	1.10	1.50	0.043	0.059
M	0° 10°		0° 10°	
Q <sub>1</sub>	0.70	0.90	0.028	0.035
Z	---	0.78	---	0.031

MC14551B

勝特力材料 886-3-5753170  
勝特力电子(上海) 86-21-54151736  
勝特力电子(深圳) 86-755-83298787  
[Http://www.100y.com.tw](http://www.100y.com.tw)

**ON Semiconductor** and  are trademarks of Semiconductor Components Industries, LLC (SCILLC). SCILLC reserves the right to make changes without further notice to any products herein. SCILLC makes no warranty, representation or guarantee regarding the suitability of its products for any particular purpose, nor does SCILLC assume any liability arising out of the application or use of any product or circuit, and specifically disclaims any and all liability, including without limitation special, consequential or incidental damages. "Typical" parameters which may be provided in SCILLC data sheets and/or specifications can and do vary in different applications and actual performance may vary over time. All operating parameters, including "Typicals" must be validated for each customer application by customer's technical experts. SCILLC does not convey any license under its patent rights nor the rights of others. SCILLC products are not designed, intended, or authorized for use as components in systems intended for surgical implant into the body, or other applications intended to support or sustain life, or for any other application in which the failure of the SCILLC product could create a situation where personal injury or death may occur. Should Buyer purchase or use SCILLC products for any such unintended or unauthorized application, Buyer shall indemnify and hold SCILLC and its officers, employees, subsidiaries, affiliates, and distributors harmless against all claims, costs, damages, and expenses, and reasonable attorney fees arising out of, directly or indirectly, any claim of personal injury or death associated with such unintended or unauthorized use, even if such claim alleges that SCILLC was negligent regarding the design or manufacture of the part. SCILLC is an Equal Opportunity/Affirmative Action Employer.