

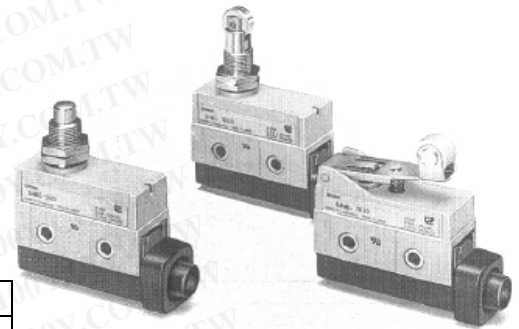







成本低、實用性高的密封開關

- 1,000 萬次以上的長壽命，內藏微動開關，反覆精度高。
- 面板安裝式的動作位置和 Z 型相符。
- 比微動開關更要求強度、防塵性和防滲性的用途最廣泛。
- 也可將端子用樹脂封口之模壓端子型。



種類

傳動軸種類	型式	取得規格	
		CL	CSA
 面板安裝 柱塞型	D4MC-5000 型	●	●
 面板安裝 滾輪柱塞型	D4MC-5020 型	●	●
 面板安裝 叉狀滾輪 柱塞型	D4MC-5040 型	●	●
 樞軸 短手柄型	D4MC-1020 型	●	●
 樞軸 手柄型	D4MC-1000 型	●	●
 樞軸滾輪 手柄型	D4MC-2000 型	●	●
 樞軸 滾輪短手柄型	D4MC-2020 型	●	●
 單向動作 樞軸滾輪 短手柄型	D4MC-2030 型	●	●

註：1. 在塵埃、油滴和濕氣過多的場所請使用模壓端子型。
備有右側引出、左側引出、下側引出三種類型。
2. 備有微小負載型，關於型號例如下。
(例) D4MC-5020 型 → D4MC-5020-C 型

構造

電線線的出線方向利用變更端子保護罩即可由左右任何一方配線

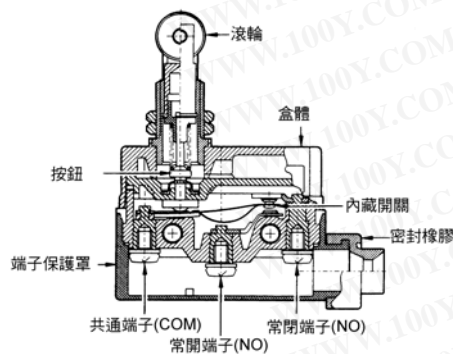

接觸型式

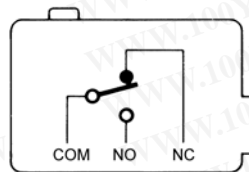

型式基準

D4MC-

① 傳動軸種類

- 5000：面板安裝柱塞型
- 5020：面板安裝滾輪柱塞型
- 5040：面板安裝叉狀滾輪柱塞型
- 1020：樞軸短手柄型
- 1000：樞軸手柄型
- 2000：樞軸滾輪手柄型
- 2020：樞軸滾輪短手柄型
- 3030：單向樞軸滾輪短手柄型

勝特力材料 886-3-5753170
 勝特力电子(上海) 86-21-54151736
 勝特力电子(深圳) 86-755-83298787
[Http://www.100y.com.tw](http://www.100y.com.tw)

■ 額定

額定電壓	非電感性負載 (A)				電感性負載 (A)			
	阻抗負載		顯示燈負載		電感性負載		電動機負載	
	常時閉路 (NC)	常時開路 (NO)	常時閉路 (NC)	常時開路 (NO)	常時閉路 (NC)	常時開路 (NO)	常時閉路 (NC)	常時開路 (NO)
AC 125	10		3	1.5	10		5	2.5
250	10		2.5	1.25	10		3	1.5
480	3		1.5	0.75	2.5		1.5	0.75
DC 8	10		3	1.5	6		5	2.5
14	10		3	1.5	6		5	2.5
30	6		3	1.5	5		5	2.5
125	0.5		0.4	0.4	0.05		0.05	0.05
250	0.25		0.2	0.2	0.03		0.03	0.03

突波	常時閉路	最大 30A
	常時開路	最大 15A

- 註：1. 以上數值為額定電流。
 2. 電感性負載係指功率 0.4 以上（交流）、額定時間 7ms 以下（直流）。
 3. 顯示燈負載是有 10 倍突波的負載。
 4. 電動機負載是有 6 倍突波的負載。
 5. 上表額定在 JISC4508 基準下所做的試驗。
 (1) 環境溫度：20±2°C
 (2) 環境濕度：65±5%RH
 (3) 操作頻率：20 次/min

■ 安全規格認證額定

UL/CSA
 A300

額定電壓	過電電流	電流 (A)		(VA)	
		投入	切斷	投入	切斷
120VAC	10A	60	6	7,200	720
240VAC		30	3		

UL/CSA
 微小負載

0.1A 125VAC
0.1A 30V DC

EN60947-5-1 適合

■ 性能

保護構造	IP67	
壽命	機械性	1,000 萬次以上
	電氣性	50 萬次以上
公差操作速度	0.05mm~0.5m/s * 1	
公差動作頻率	機械性	120 次/分
	電氣性	20 次/分
額定脈波數	50/60Hz	
絕緣阻抗	100MΩ 以上 (DC500V)	
接觸阻抗	15mΩ 以下 (初期值)	
耐電壓	鉗極端弓之間	AC1,000V 50/60Hz 1min
	孔電氣接觸部與接地間	AC2,000V 50/60Hz 1min
	鉗極弓與非電氣接觸部	AC2,000V 50/60Hz 1min
額定絕緣電流 (Ui)	1,000VAC	
污染度 (使用環境)	3(IEC947-5-1)	
觸電保護等級	Class II	
PTI	175	
開關類別	D(IEC335)	
額定動作電流 (Ie)	10A	
額定動作電壓 (Ue)	AC250V	
振動	誤動作	10~55Hz 複振幅 1.5mm * 2
	耐久	最大 1,000m/s ² {100G}
衝擊	誤動作	最大 100m/s ² {10G} * 1 * 2
	耐久	
使用環境溫度	-10~+80°C (但不結冰)	
使用環境濕度	35~95%RH	
重量	約 71g (面板安裝柱塞型時)	

- * 1. 為柱塞型。
 * 2. 自由狀態動作限度位置為 1ms 以內。

■ 特性曲線

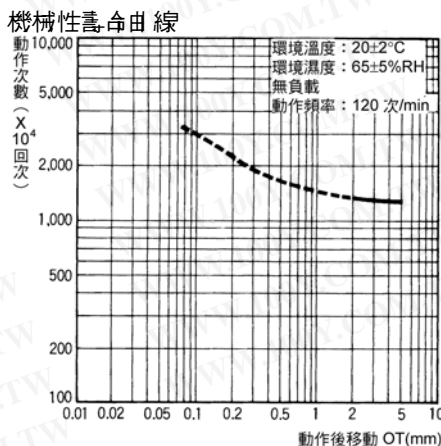
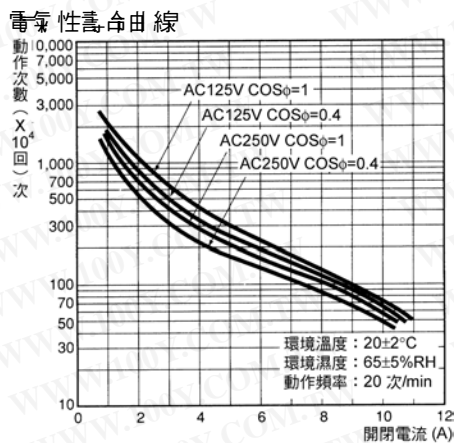

■ 外觀尺寸 / 動作特性

面板安裝柱塞型
D4MC-5000 型

CAD 檔 D4MC_06

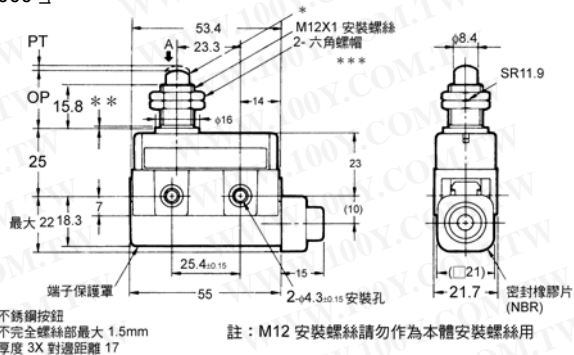

面板安裝滾柱塞型
D4MC-5020 型

CAD 檔 D4MC_07

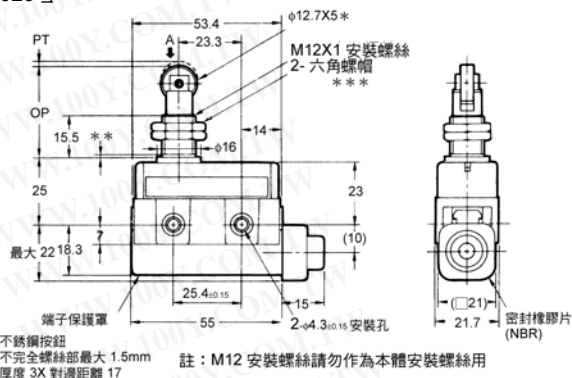

面板安裝叉狀滾柱塞型
D4MC-5040 型

CAD 檔 D4MC_08

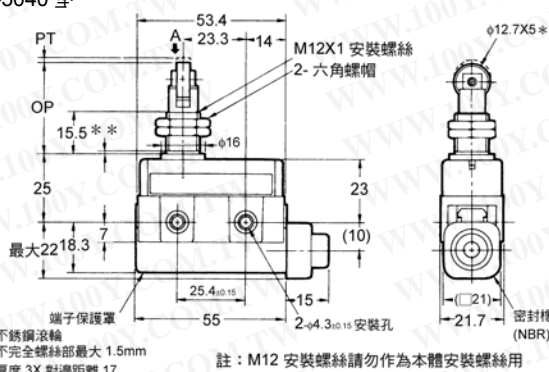

框轉按鈕型
D4MC-1020 型

CAD 檔 D4MC_02

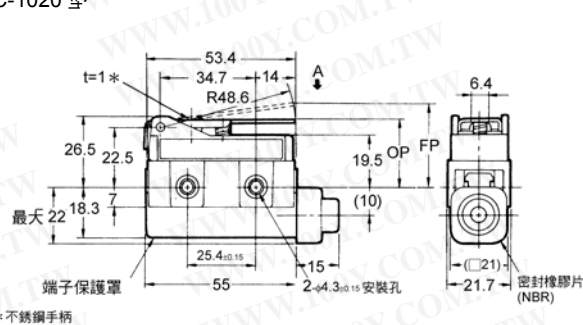

框轉十字型
D4MC-1000 型

CAD 檔 D4MC_01

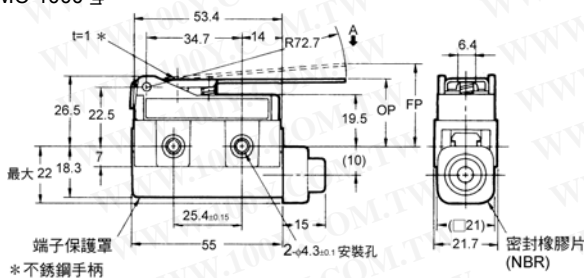

框轉滾輪十字型
D4MC-2000 型

CAD 檔 D4MC_03

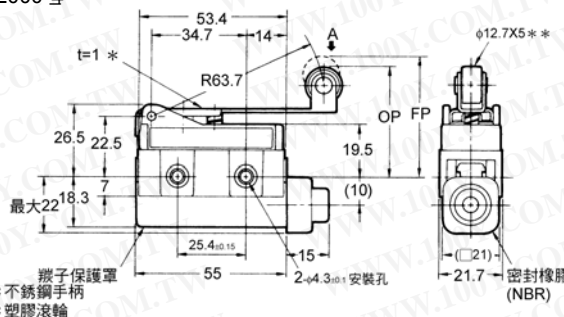

框轉滾輪十字型
D4MC-2020 型

CAD 檔 D4MC_04

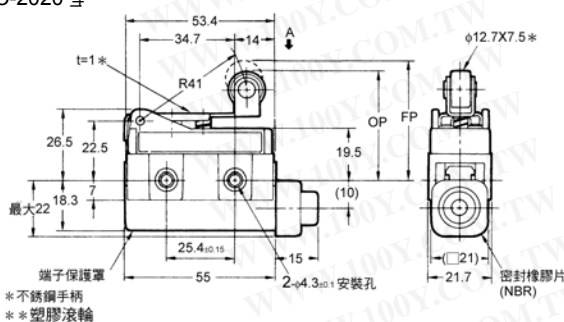

單止動作框轉十字型
D4MC-3030 型

CAD 檔 D4MC_05

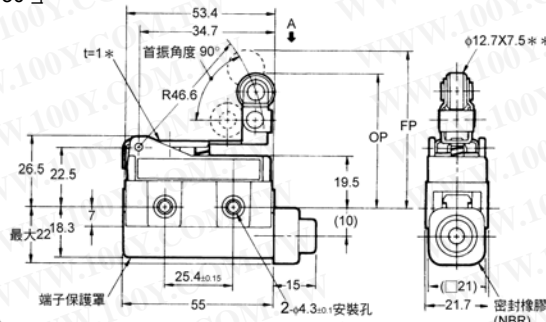

註: 1. 上列各機種之外觀尺寸圖中, 未指定部份之尺寸公差是 ±0.4mm。

2. 動作特性是由 A 方向來的動作所測定的值。

3. OT 請勿超過規格值。

動作特性	型式	D4MC-5000 型	D4MC-5020 型	D4MC-5040 型	D4MC-1020 型	D4MC-1000 型	D4MC-2000 型	D4MC-2020 型	D4MC-3030 型
動作電力量	OF 最大	5.88N {600gf}	5.88N {600gf}	5.88N {600gf}	2.55N {260gf}	1.67N {170gf}	1.96N {200gf}	2.94N {300gf}	2.94N {300gf}
	RF 最小	0.98N {100gf}	0.98N {100gf}	0.98N {100gf}	0.34N {35gf}	0.25N {25gf}	0.39N {40gf}	0.39N {40gf}	0.39N {40gf}
動作前移動	PT 最大	1.6mm	1.6mm	1.6mm	—	—	—	—	—
	OT 最小	5mm	5mm	5mm	2.5mm	4mm	5mm	2mm	2mm
動作後移動	OT 最大	—	—	—	—	—	—	—	—
	MD 最大	0.2mm	0.2mm	0.2mm	1.7mm	3mm	3mm	1.5mm	1.5mm
自由位置	FP 最大	—	—	—	33mm	36mm	51mm	47mm	57.2mm
	OP 最大	21.8±1.2mm	33.4±1.2mm	33.4±1.2mm	25±1mm	25±1mm	40±1mm	40±1mm	50±1mm

Enclosed Switch

D4MC

Economical, High Utility Enclosed Switch

- High precision and long life (10,000,000 mechanical operations) through employment of the moving spring used in OMRON Z Basic Switch.
- Sealed with gasket diaphragm to provide high sealing property without use of any adhesive or pin.
- Suitable for applications demanding higher mechanical strength, dustproof and drip-proof properties than those on basic switches.
- Panel mount versions have the same operating position as Z Basic Switch.
- Resin molded terminal versions are available.



Ordering Information

■ Model Number Legend









D4MC-

1

1. Actuator

- 5000: Panel mount plunger
- 5020: Panel mount roller plunger
- 5040: Panel mount crossroller plunger
- 1020: Short hinge lever
- 1000: Hinge lever
- 2000: Hinge roller lever
- 2020: Short hinge roller lever
- 3030: One-way action short hinge roller lever

■ List of Models

Actuator	Model
Panel mount plunger 	D4MC-5000
Panel mount roller plunger 	D4MC-5020
Panel mount crossroller plunger 	D4MC-5040
Short hinge lever 	D4MC-1020
Hinge lever 	D4MC-1000
Hinge roller lever 	D4MC-2000
Short hinge roller lever 	D4MC-2020
One-way action short hinge roller lever 	D4MC-3030

- Note:**
1. Use molded terminal models (refer to page 209) when using the Switch under one of the following conditions:
 - a) dusty, b) high amount of dripping oil, or c) high humidity
 2. Micro-load models are available.

e.g. Standard model	Micro-load model
D4MC-5020	D4MC-5020-C

Specifications

■ Ratings

Rated voltage	Non-inductive load				Inductive load			
	Resistive load		Lamp load		Inductive load		Motor load	
	NC	NO	NC	NO	NC	NO	NC	NO
125 VAC	10 A		3 A	1.5 A	10 A		5 A	2.5 A
250 VAC	10 A		2.5 A	1.25 A	10 A		3 A	1.5 A
480 VAC	3 A		1.5 A	0.75 A	2.5 A		1.5 A	0.75 A
8 VDC	10 A		3 A	1.5 A	6 A		5 A	2.5 A
14 VDC	10 A		3 A	1.5 A	6 A		5 A	2.5 A
30 VDC	6 A		3 A	1.5 A	5 A		5 A	2.5 A
125 VDC	0.5 A		0.4 A		0.05 A		0.05 A	
250 VDC	0.25 A		0.2 A		0.03 A		0.03 A	

Inrush current	NC	30 A max.
	NO	15 A max.

- Note:**
- The above figures are for steady-state currents.
 - Inductive loads have a power factor of 0.4 min. (AC) and a time constant of 7 ms max. (DC).
 - Lamp load has an inrush current of 10 times the steady-state current.
 - Motor load has an inrush current of 6 times the steady-state current.
 - The above ratings were tested under the following conditions according to JIS C4508.
 - Ambient temperature: 20±2°C
 - Ambient humidity: 65±5%
 - Operating frequency: 20 operations/min

■ Approved Standard Ratings

UL/CSA

A300

Rated voltage	Carry current	Current		Volt-amperes	
		Make	Break	Make	Break
120 VAC	10 A	60 A	6 A	7,200 VA	720 VA
240 VAC		30 A	3 A		

Micro load: 0.1 A, 125 VAC
0.1 A, 30 VDC

EN60947-1 and EN60947-5-1

250 V, 10 A (AC-12)

■ Characteristics

Degree of protection	IP67 (NEMA250: 6.6P)
Life expectancy	Mechanical: 10,000,000 operations min. Electrical: 500,000 operations min.
Operating speed	0.05 mm/s to 0.5 m/s (at panel mount plunger)
Operating frequency	Mechanical: 120 operations/min Electrical: 20 operations/min
Insulation resistance	100 MΩ min. (at 500 VDC)
Contact resistance	15 mΩ max. (initial value)
Dielectric strength	1,000 VAC, 50/60 Hz for 1 min between terminals of the same polarity 2,000 VAC, 50/60 Hz for 1 min between current-carrying metal parts and ground, and between each terminal and non-current-carrying part
Rated insulation voltage (U _i)	1,000 VAC
Pollution degree (operating environment)	3 (IEC947-5-1)
Protection against electric shock	Class II
PTI (tracking characteristics)	175
Switch category	D (IEC335)
Rated operating current (I _e)	10 A
Rated operating voltage (U _e)	250 VAC
Vibration resistance	Malfunction: 10 to 55 Hz, 1.5-mm double amplitude (see note)
Shock resistance	Destruction: 1,000 m/s ² min. Malfunction: 100 m/s ² min. (in case of plunger) (see note)
Ambient temperature	Operating: -10°C to 80°C (with no icing)
Ambient humidity	Operating: 35% to 95%
Weight	Approx. 71 g (at panel mount plunger)

Note: Less than 1 ms under a free state at the operating limits.

■ Approved Standards (Except Molded Terminal Models)

UL (File No. E76675)/CSA (File No. E45258)

■ Operating Characteristics

Model	D4MC-5000	D4MC-5020	D4MC-5040	D4MC-1020	D4MC-1000	D4MC-2000	D4MC-2020	D4MC-3030
OF max.	5.88 N	5.88 N		2.55 N	1.67 N	1.96 N	2.94 N	2.94 N
RF min.	0.98 N	0.98 N		0.34 N	0.25 N	0.39 N	0.39 N	0.39 N
PT max.	1.6 mm	1.6 mm		---	---	---	---	---
OT min.	5 mm	5 mm		2.5 mm	4 mm	5 mm	2 mm	2 mm
MD max.	0.2 mm	0.2 mm		1.7 mm	3 mm	3 mm	1.5 mm	1.5 mm
OP	21.8± 1.2 mm	33.4±1.2 mm		25±1 mm	25±1 mm	40±1 mm	40±1 mm	50±1 mm
FP max.	---	---		33 mm	36 mm	51 mm	47 mm	57.2 mm

Engineering Data (Reference Data)

Mechanical Life Expectancy (D4MC-5000)

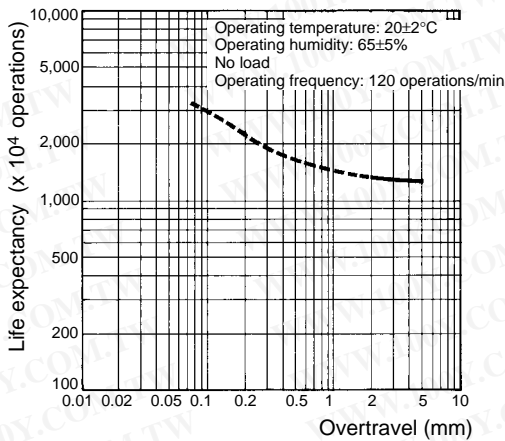

Electrical Life Expectancy

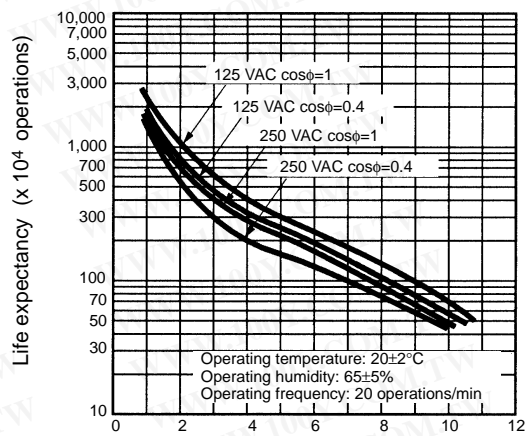

Operation

Contact Form

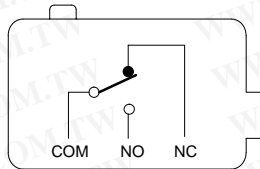

Dimensions

- Note:**
- All units are in millimeters unless otherwise indicated.
 - Unless otherwise specified, a tolerance of ±0.4 mm applies to all dimensions.

Panel Mount Plunger D4MC-5000

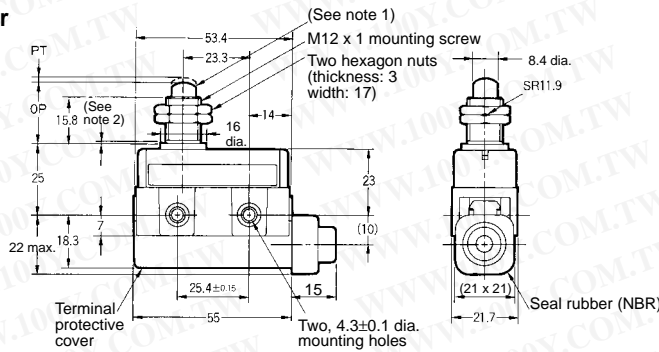

- Note:**
- Stainless steel plunger
 - The length of the imperfect threads is 1.5 mm maximum.

Panel Mount Roller Plunger D4MC-5020

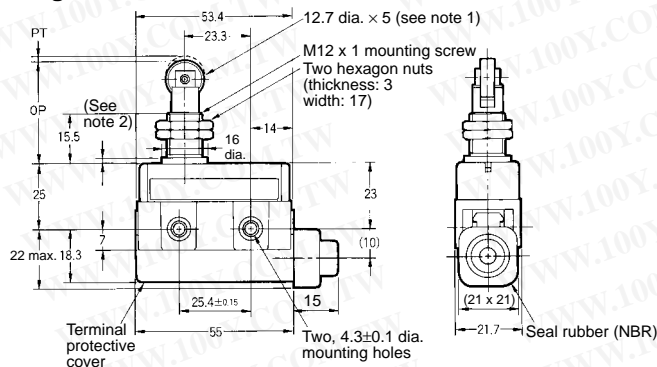

- Note:**
- Stainless steel roller
 - The length of the imperfect threads is 1.5 mm maximum.

**Panel Mount Crossroller Plunger
D4MC-5040**

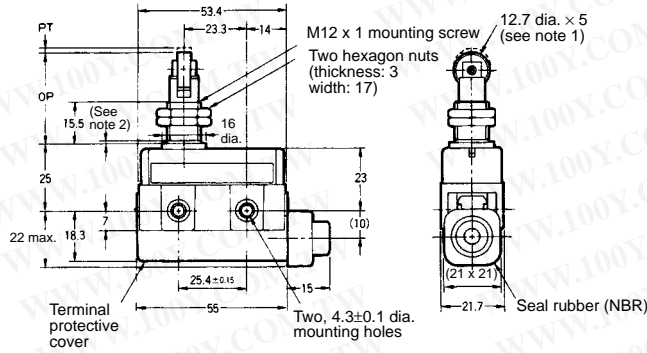

- Note:**
1. Stainless steel roller
 2. The length of the imperfect threads is 1.5 mm maximum.

**Short Hinge Lever
D4MC-1020**

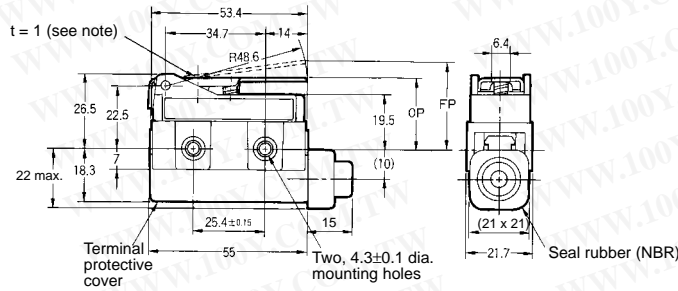

- Note:** Stainless steel lever

**Hinge Lever
D4MC-1000**

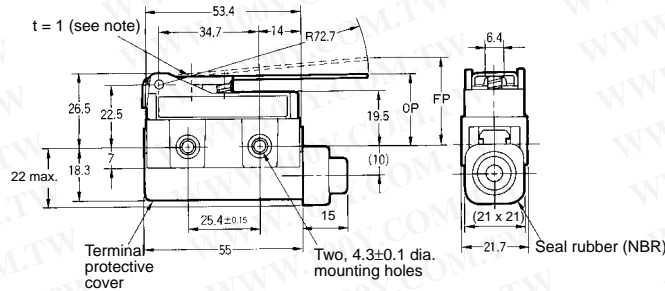

- Note:** Stainless steel lever

**Hinge Roller Lever
D4MC-2000**

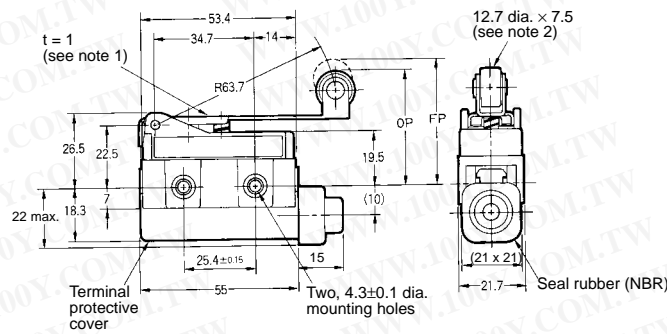

- Note:**
1. Stainless steel lever
 2. Plastic roller

**Short Hinge Roller Lever
D4MC-2020**

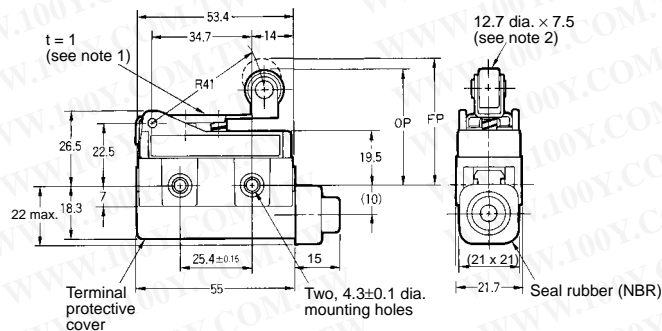

- Note:**
1. Stainless steel lever
 2. Plastic roller

**One-way Action Short Hinge Roller Lever
D4MC-3030**

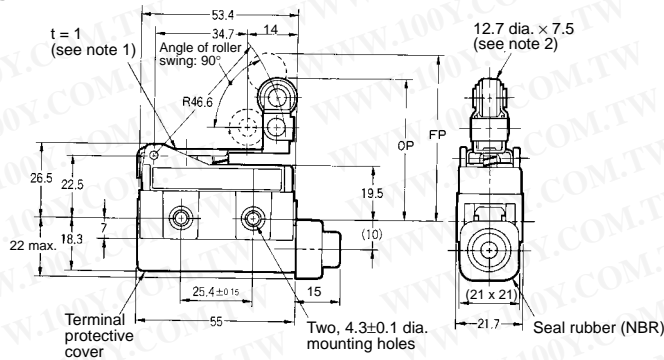

Mounting Holes

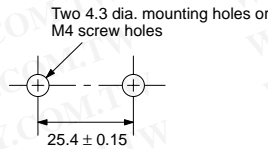

Molded Terminal Models

■ **Molded Terminal Models**

The molded terminal model is available with right-hand, left-hand and underside leads and is recommended for use where the Switch is exposed to dust, oil, or moisture.

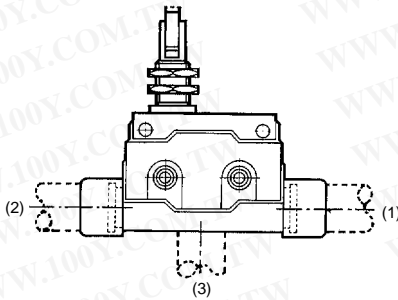

When placing your order for the Switch specify the required length of V.C.T. cable in addition to the model number of the Switch

Example:

Standard type: D4MC-5040
 Location of lead outlet: Underside
 Length of lead: 1 m (V.C.T. lead)
 When placing your order for the above Switch specify the model number as D4MC-5043 (V.C.T 1 m)

Suffix by Location of Lead Outlet

Location of lead outlet	Model
	COM, NC, and NO
Right-hand	D4MC-□□□1
Left-hand	D4MC-□□□2
Underside	D4MC-□□□3

Leads Supplied

Leads	Nominal cross-sectional area	Finished outside diameter	Terminal connections	Standard length
V.C.T. (Vinyl cabtire cable)	1.25 mm ²	Triple conductor: 10.5 mm dia.	Black: COM White: NO Red: NC	1, 3, 5 m

■ **Terminal Protective Cover**

ZC55 Terminal Cover (ZC55-0002H):
 The following three parts are supplied as a set.

ZC Seal Rubber (SC-1404C)

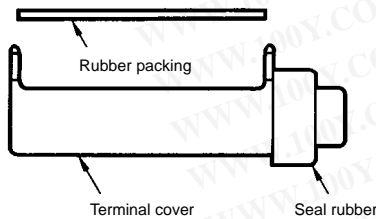

Precautions

■ Correct Use

Operating Method

Excessive dog angle, operating speed, or overtravel (OT) may damage the actuator. Check that OT has a sufficient margin. The actual OT should be rated OT x 0.7 to 1.

Handling

- Do not expose the Switch to water exceeding 60°C or use it in steam.
- Do not use the Switch in oil or water.
- An 8.5- to 10.5-dia. cable can be applied as seal rubber for the lead wire outlet. (Use two- or three-core cable of VCT1.25 mm².)
- When detaching the Terminal Protective Cover, insert a screwdriver and apply a force in the opening direction. Do not use excess force to remove the cover. Doing so may cause deformation in the fitting section and reduce the holding force.

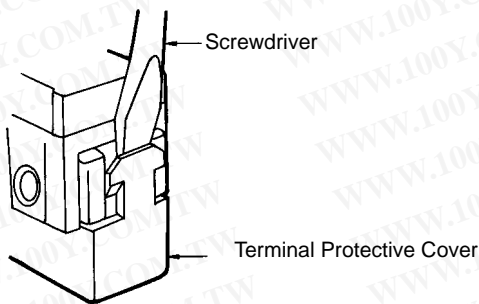

When mounting the Terminal Protective Cover to the case, align the cover on the case and then press the cover down to mount it firmly. If the cover is pressed down in an inclined position, rubber packing will deform and thus affect the sealing capability.

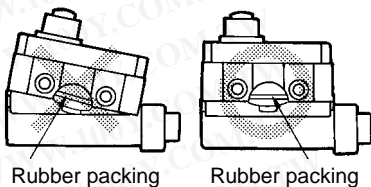

Mounting

When mounting the Switch with screws on a side surface, fasten the Switch with M4 screws and use washers, spring washers, etc., to ensure secure mounting.

Mounting Holes

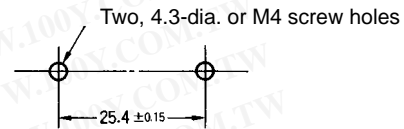

- When mounting the Panel Mount-type Switch (DCMC-5000, D4MC5020, or D4MC5040) with screws on a side surface, remove the hexagonal nuts from the actuator.
- When mounting the panel mount type on a panel, be careful not to tighten to an excessive torque. Tightening the screws to a torque exceeding 4.91 N • m will cause the plunger to fail.

Mounting Hole Dimensions

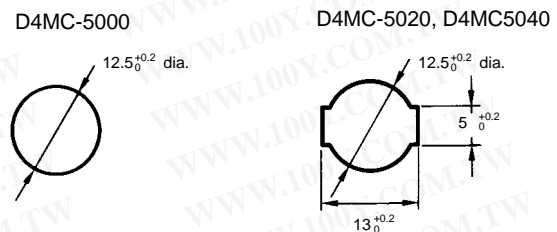

Correct Tightening Torque

A loose screw may cause malfunctions. Be sure to tighten each screw to the proper tightening torque as shown in the table.

No.	Type	Torque
1	Terminal screw	0.78 to 1.18 N • m
2	Panel mounting screw	2.94 to 4.92 N • m
3	Side mounting screw	1.18 to 1.47 N • m

ALL DIMENSIONS SHOWN ARE IN MILLIMETERS.

To convert millimeters into inches, multiply by 0.03937. To convert grams into ounces, multiply by 0.03527.