

勝特力材料 886-3-5753170
 勝特力电子(上海) 86-21-54151736
 勝特力电子(深圳) 86-755-83298787
[Http://www.100y.com.tw](http://www.100y.com.tw)

A. Material List		
NO.	ITEM	DESCRIPTION
1	TERMINAL	SQNB5-3.7
2	COATING RESIN	BLACK EPOXY
3	LEAD WIRE	UL 1430#22 TC (白色線)
B. Electrical Characteristic		
ITEM	VALUE	
R25	50 ±5%	
B25/50	3100K±5%	

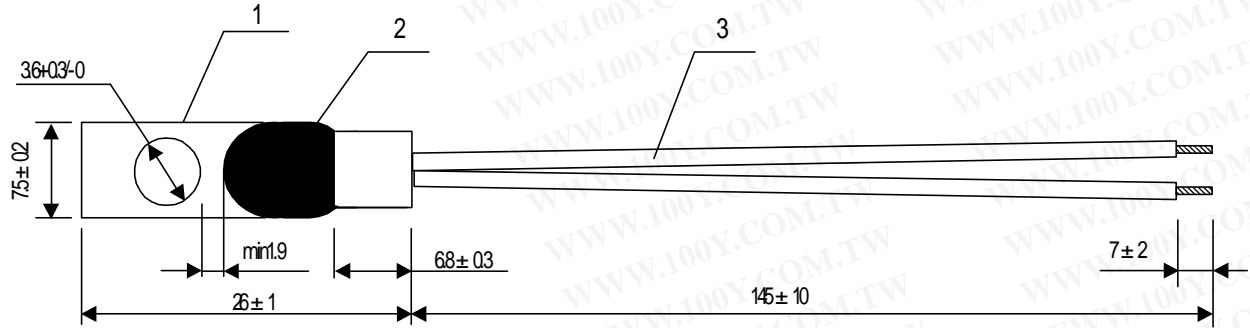

Specification of NTC Thermistor for Sensor

PART NO. NTSA0500JG001

CUSTOMER P/N. _____

勝特力材料 886-3-5753170
 勝特力电子(上海) 86-21-54151736
 勝特力电子(深圳) 86-755-83298787
[Http://www.100y.com.tw](http://www.100y.com.tw)

2. Electrical characteristics

	Parameter	Symbol	Test Conditions	Min.	Nor.	Max.	Unit.
a.	Resistance At 25	R ₂₅	Ta=25 ±0.1 I<0.5mA	0.048	0.05	0.053	KOHM
b.	Resistance At 50	R ₅₀	Ta=50 ±0.1 I<0.5mA	-----	3.497	-----	KOHM
c.	R ₂₅ / R ₅₀	K	-----	-----	2.859	-----	-----
d.	B Constant	B	(8876 Log K)	2945	3100	3255	K
e.	Thermal Dissipation Constant	C	Ta=25 ±0.1	-----	20	-----	mW/
f.	Thermal Time Constant	-----	Ta=25 ±0.1	-----	18	-----	Sec
g.	Hi-Pot Test	-----	1000V AC 3 sec	-----	----	10	mA

3. Maximum Ratings

	Parameter	Specification	Unit
a.	Operation Temperature Range	- 10 --- 105	
b.	Max' Permissible Current	470	mA
c.	Max' Operating Current	235	mA

4. Mechanical Characteristics

4-1 Leads Terminal Tensile Strength

Conditions	Test Result	
Fasten body with a Load Applied to each lead 1 kg for 5 sec.	No break out and damage	OK

5. Reliability Test

Item	Test Conditions	Variable
Temp. cycle test	-10 X 30min +25 X 5 min +105 X 30min +25 X 5 min } 10cycles	Within ± 5 %
Humidity test	45 95 % RH X 1000 HRS	Within ± 5 %
Life test	470 mAmp. X 1000 HRS	Within ± 5 %

