

# LM129/LM329

## Precision Reference

勝特力材料 886-3-5753170  
 勝特力电子(上海) 86-21-54151736  
 勝特力电子(深圳) 86-755-83298787  
[Http://www.100y.com.tw](http://www.100y.com.tw)

### General Description

The LM129 and LM329 family are precision multi-current temperature-compensated 6.9V zener references with dynamic impedances a factor of 10 to 100 less than discrete diodes. Constructed in a single silicon chip, the LM129 uses active circuitry to buffer the internal zener allowing the device to operate over a 0.5 mA to 15 mA range with virtually no change in performance. The LM129 and LM329 are available with selected temperature coefficients of 0.001, 0.002, 0.005 and 0.01%/°C. These references also have excellent long term stability and low noise.

A new subsurface breakdown zener used in the LM129 gives lower noise and better long-term stability than conventional IC zeners. Further the zener and temperature compensating transistor are made by a planar process so they are immune to problems that plague ordinary zeners. For example, there is virtually no voltage shift in zener voltage due to temperature cycling and the device is insensitive to stress on the leads.

The LM129 can be used in place of conventional zeners with improved performance. The low dynamic impedance simplifies biasing and the wide operating current allows the replacement of many zener types.

The LM129 is packaged in a 2-lead TO-46 package and is rated for operation over a -55°C to +125°C temperature range. The LM329 for operation over 0°C to 70°C is available in both a hermetic TO-46 package and a TO-92 epoxy package.

### Features

- 0.6 mA to 15 mA operating current
- 0.6Ω dynamic impedance at any current
- Available with temperature coefficients of 0.001%/°C
- 7μV wideband noise
- 5% initial tolerance
- 0.002% long term stability
- Low cost
- Subsurface zener

### Connection Diagrams

Metal Can Package (TO-46)

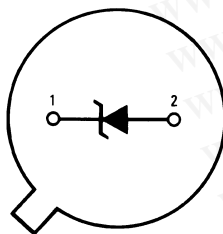

DS005714-6

Pin 2 is electrically connected to case

#### Bottom View

**Order Number LM129AH, LM129AH/883, LM129BH,**  
**LM129BH/883, LM129CH, LM329AH, LM329BH,**  
**LM329CH or LM329DH**  
**See NS Package H02A**

Plastic Package (TO-92)

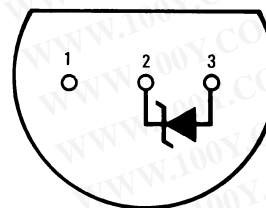

DS005714-4

#### Bottom View

**Order Number LM329BZ,**  
**LM329CZ or LM329DZ**  
**See NS Package Z03A**

## Typical Applications

### Simple Reference

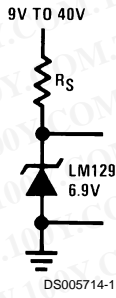

勝特力材料 886-3-5753170  
勝特力电子(上海) 86-21-54151736  
勝特力电子(深圳) 86-755-83298787  
[Http://www.100y.com.tw](http://www.100y.com.tw)

**Absolute Maximum Ratings** (Note 1)

If Military/Aerospace specified devices are required, please contact the National Semiconductor Sales Office/Distributors for availability and specifications.

(Note 3)

Reverse Breakdown Current	30 mA	Operating Temperature Range	LM129	-55°C to +125°C
Forward Current	2 mA		LM329	0°C to +70°C
		Storage Temperature Range		-55°C to +150°C
		Soldering Information		
		TO-92 package: 10 sec.		260°C
		TO-46 package: 10 sec.		300°C

**Electrical Characteristics** (Note 2)

Parameter	Conditions	LM129A, B, C			LM329A, B, C, D			Units
		Min	Typ	Max	Min	Typ	Max	
Reverse Breakdown Voltage	$T_A = 25^\circ\text{C}$ , $0.6\text{ mA} \leq I_R \leq 15\text{ mA}$	6.7	6.9	7.2	6.6	6.9	7.25	V
Reverse Breakdown Change with Current (Note 4)	$T_A = 25^\circ\text{C}$ , $0.6\text{ mA} \leq I_R \leq 15\text{ mA}$		9	14		9	20	mV
Reverse Dynamic Impedance (Note 4)	$T_A = 25^\circ\text{C}$ , $I_R = 1\text{ mA}$		0.6	1		0.8	2	$\Omega$
RMS Noise	$T_A = 25^\circ\text{C}$ , $10\text{ Hz} \leq F \leq 10\text{ kHz}$		7	20		7	100	$\mu\text{V}$
Long Term Stability (1000 hours)	$T_A = 45^\circ\text{C} \pm 0.1^\circ\text{C}$ , $I_R = 1\text{ mA} \pm 0.3\%$		20			20		ppm
Temperature Coefficient	$I_R = 1\text{ mA}$							
LM129A, LM329A			6	10		6	10	ppm/°C
LM129B, LM329B			15	20		15	20	ppm/°C
LM129C, LM329C			30	50		30	50	ppm/°C
LM329D						50	100	ppm/°C
Change In Reverse Breakdown Temperature Coefficient	$1\text{ mA} \leq I_R \leq 15\text{ mA}$		1			1		ppm/°C
Reverse Breakdown Change with Current	$1\text{ mA} \leq I_R \leq 15\text{ mA}$		12			12		mV
Reverse Dynamic Impedance	$1\text{ mA} \leq I_R \leq 15\text{ mA}$		0.8			1		$\Omega$

**Note 1:** "Absolute Maximum Ratings" indicate limits beyond which damage to the device may occur. Operating Ratings indicate conditions for which the device is functional, but do not guarantee specific performance limits.

**Note 2:** These specifications apply for  $-55^\circ\text{C} \leq T_A \leq +125^\circ\text{C}$  for the LM129 and  $0^\circ\text{C} \leq T_A \leq +70^\circ\text{C}$  for the LM329 unless otherwise specified. The maximum junction temperature for an LM129 is  $150^\circ\text{C}$  and LM329 is  $100^\circ\text{C}$ . For operating at elevated temperature, devices in TO-46 package must be derated based on a thermal resistance of  $440^\circ\text{C/W}$  junction to ambient or  $80^\circ\text{C/W}$  junction to case. For the TO-92 package, the derating is based on  $180^\circ\text{C/W}$  junction to ambient with 0.4" lead from a PC board and  $160^\circ\text{C/W}$  junction to ambient with 0.125" lead length to a PC board.

**Note 3:** Refer to RETS129H for LM129 family military specifications.

**Note 4:** These changes are tested on a pulsed basis with a low duty-cycle. For changes versus temperature, compute in terms of tempo.

勝特力材料 886-3-5753170  
 勝特力电子(上海) 86-21-54151736  
 勝特力电子(深圳) 86-755-83298787  
[Http://www.100y.com.tw](http://www.100y.com.tw)

## Typical Applications

### Low Cost 0–25V Regulator

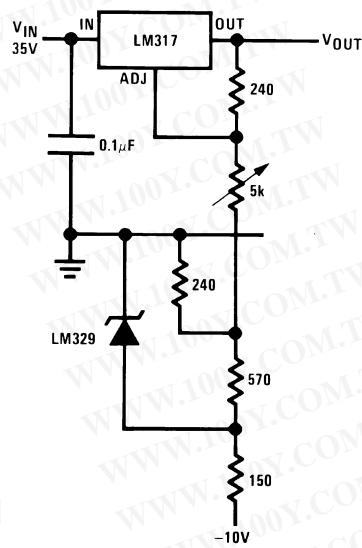

勝特力材料 886-3-5753170  
 勝特力电子(上海) 86-21-54151736  
 勝特力电子(深圳) 86-755-83298787  
[Http://www.100y.com.tw](http://www.100y.com.tw)

### Adjustable Bipolar Output Reference

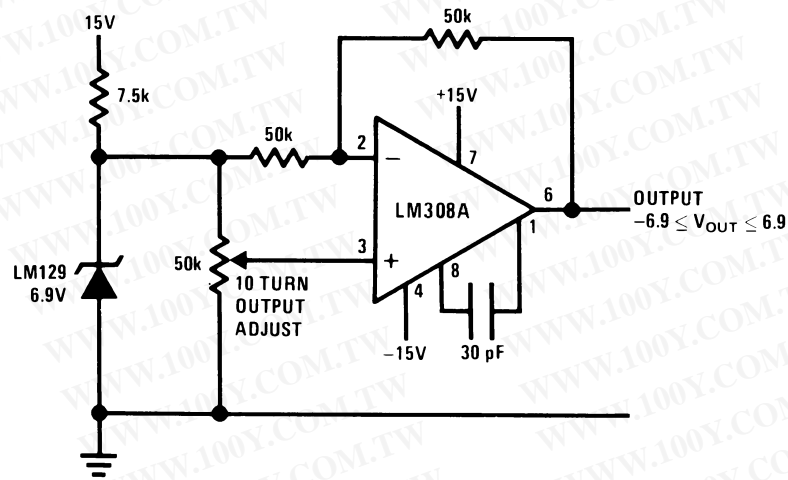

Typical Applications (Continued)

0V to 20V Power Reference

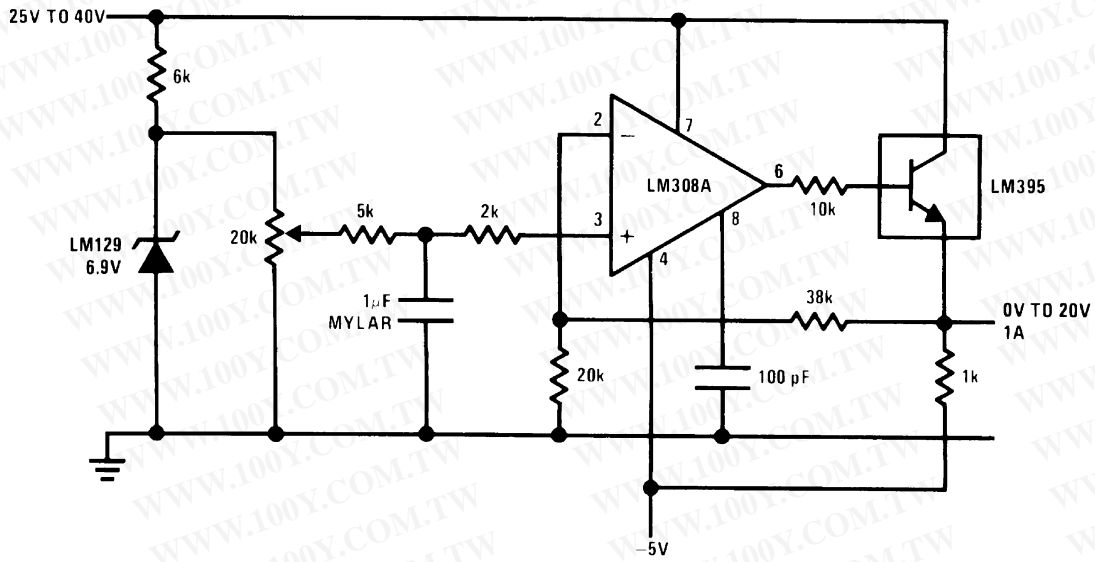

DS005714-9

External Reference for Temperature Transducer

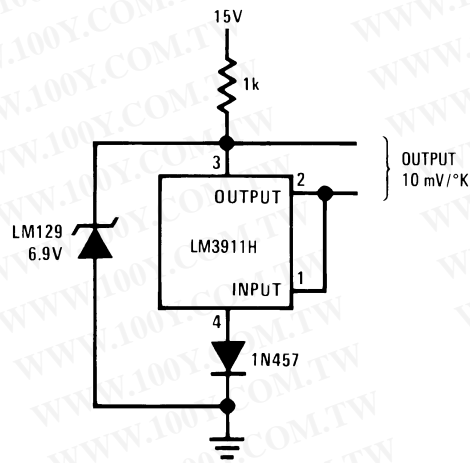

DS005714-2

勝特力材料 886-3-5753170  
 勝特力电子(上海) 86-21-54151736  
 勝特力电子(深圳) 86-755-83298787  
[Http://www.100y.com.tw](http://www.100y.com.tw)

## Typical Applications (Continued)

勝特力材料 886-3-5753170  
 勝特力电子(上海) 86-21-54151736  
 勝特力电子(深圳) 86-755-83298787  
[Http://www.100y.com.tw](http://www.100y.com.tw)

### Positive Current Source

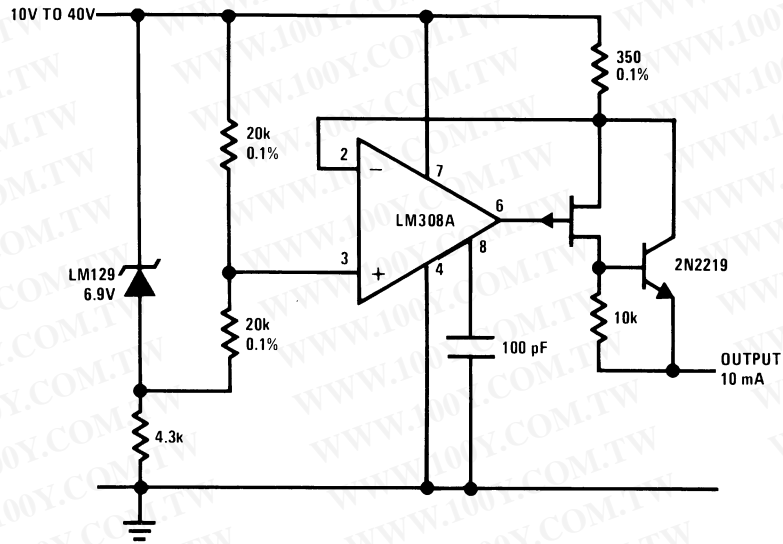

DS005714-11

### Buffered Reference with Single Supply

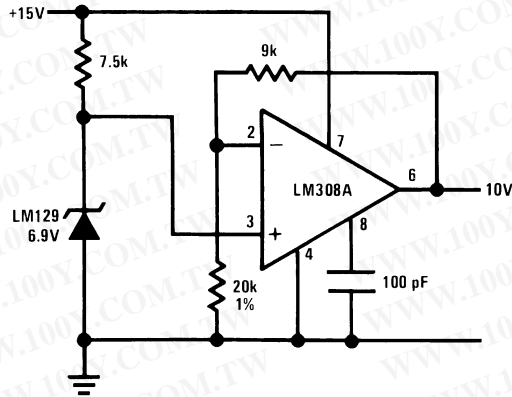

DS005714-3

### Schematic Diagram

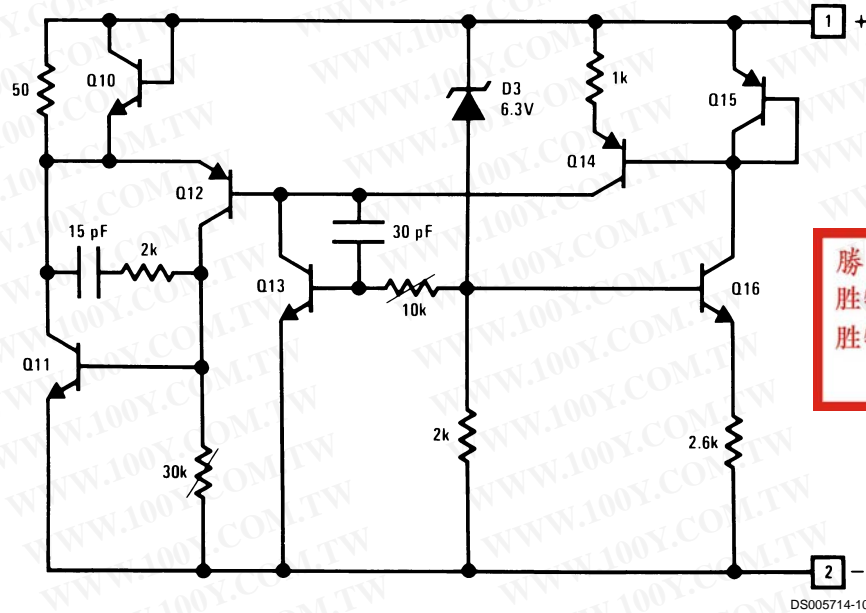

勝特力材料 886-3-5753170  
 勝特力电子(上海) 86-21-54151736  
 勝特力电子(深圳) 86-755-83298787  
[Http://www.100y.com.tw](http://www.100y.com.tw)

### Typical Performance Characteristics

Reverse Characteristics

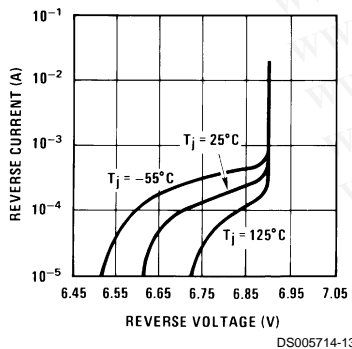

DS005714-13

Response Time

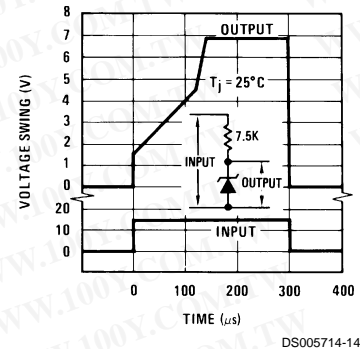

DS005714-14

Forward Characteristics

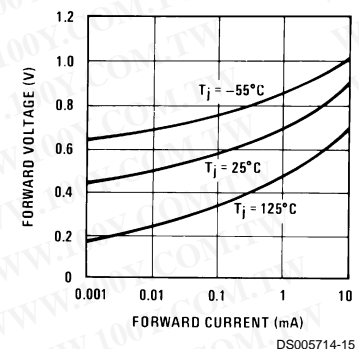

DS005714-15

Dynamic Impedance

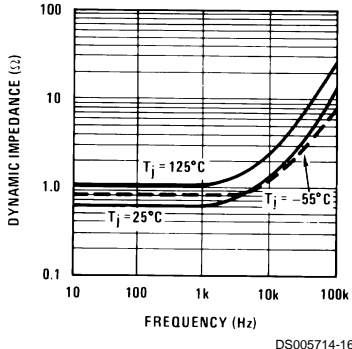

DS005714-16

Reverse Voltage Change

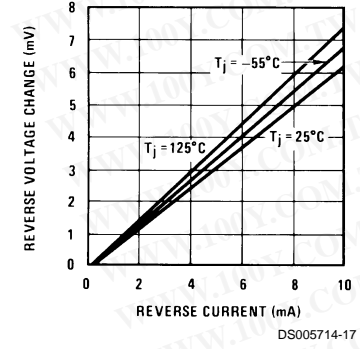

DS005714-17

Zener Noise Voltage

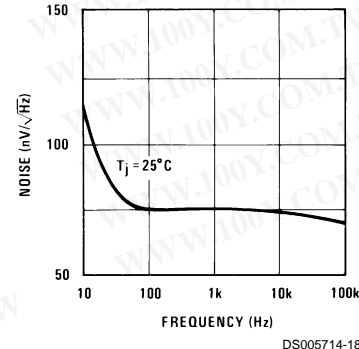

DS005714-18

## Typical Performance Characteristics (Continued)

### Low Frequency Noise Voltage

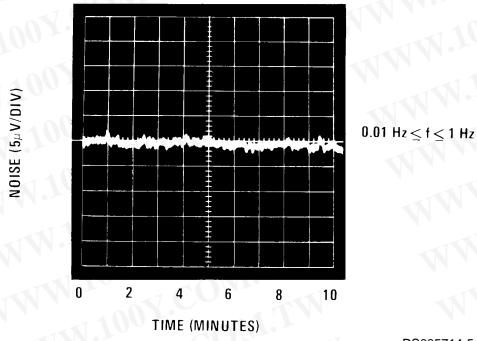

勝特力材料 886-3-5753170  
勝特力电子(上海) 86-21-54151736  
勝特力电子(深圳) 86-755-83298787  
[Http://www.100y.com.tw](http://www.100y.com.tw)

**Physical Dimensions** inches (millimeters) unless otherwise noted

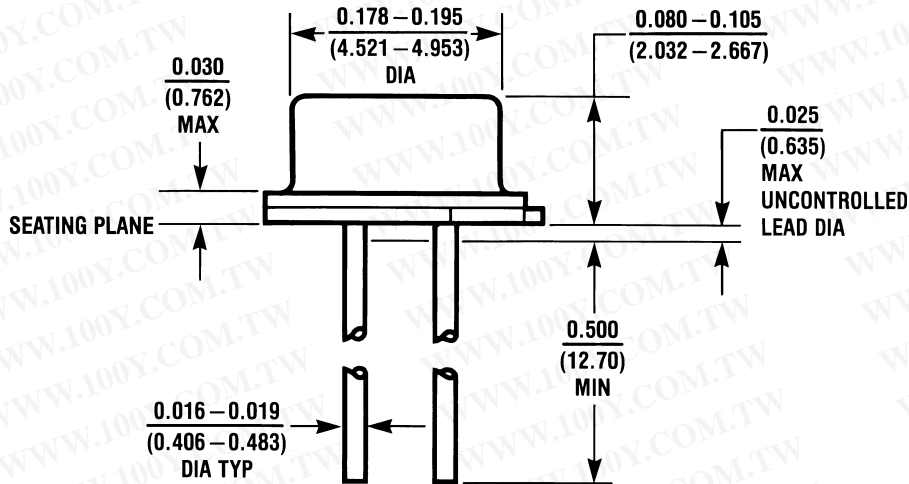

勝特力材料 886-3-5753170  
 勝特力电子(上海) 86-21-54151736  
 勝特力电子(深圳) 86-755-83298787  
[Http://www.100y.com.tw](http://www.100y.com.tw)

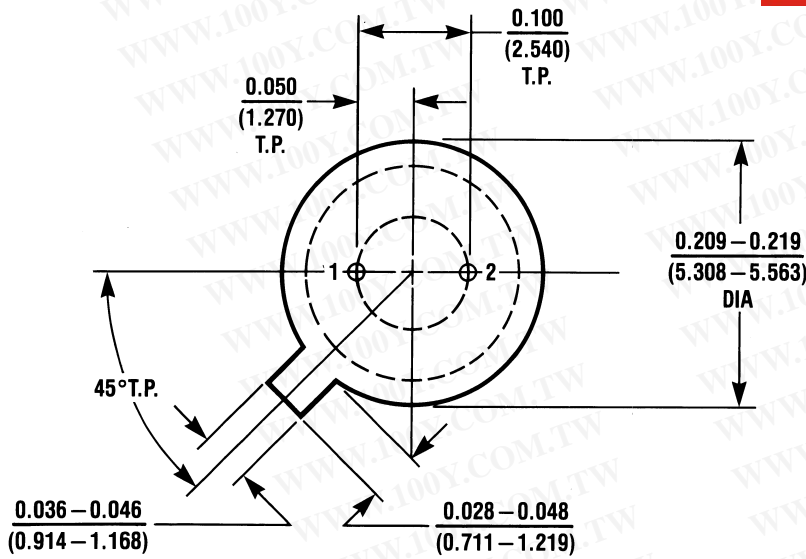

H02A (REV C)

**Metal Can Package**  
 Order Number LM129AH, LM129AH/883, LM129BH, LM129BH/883,  
 LM129CH, LM329AH, LM329BH, LM329CH, or LM329DH  
**NS Package H02A**

**Physical Dimensions** inches (millimeters) unless otherwise noted (Continued)

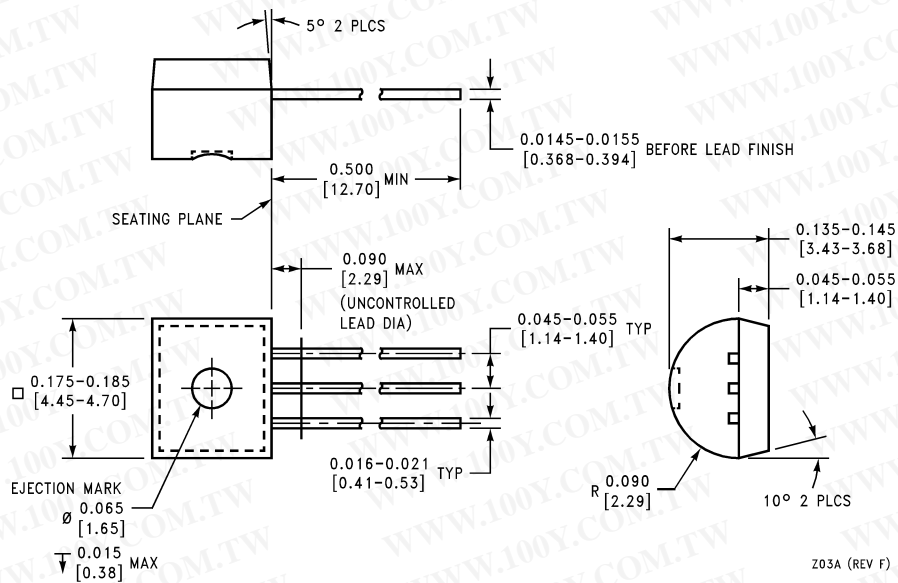

**Plastic Package**  
**Order Number LM329BZ, LM329CZ, or LM329DZ**  
**NS Package Z03A**

勝特力材料 86-3-5753170  
 勝特力电子(上海) 86-21-54151736  
 勝特力电子(深圳) 86-755-83298787  
[Http://www.100y.com.tw](http://www.100y.com.tw)