

FEATURES

- Two types available: Random type and Zero-cross type
Random type permits phase control and Zero-cross type suppresses occurrence of noise.
- Vertical type
The small-sized vertical type (43 mm long × 9 mm wide × 24 mm high) (1.693×.354×.945 inch) permits high density mounting to PC board.
- High dielectric strength: 1,500 V AC (between input and output)
4,000 V AC (between input and output)

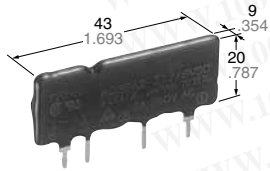

TYPICAL APPLICATIONS

- Copying equipment
- NC machines, sequencers, robots
- Air conditioners

RoHS Directive compatibility information
<http://www.mew.co.jp/ac/e/environment/>

勝特力材料 886-3-5753170
 勝特力电子(上海) 86-21-54151736
 勝特力电子(深圳) 86-755-83298787
[Http://www.100y.com.tw](http://www.100y.com.tw)

TYPES

Type	Load voltage	Input voltage	Standard type (1,500 V AC)	Reinforced type (4,000 V AC)
			Part No.	Part No.
Zero-cross 1 A	75 to 125 V AC	3 to 6 V DC	AQB1A1-ZT3/6VDC	—
		7 to 14 V DC	AQB1A1-ZT7/14VDC	—
		10 to 18 V DC	AQB1A1-ZT10/18VDC	—
		18 to 30 V DC	AQB1A1-ZT18/30VDC	—
	75 to 250 V AC	3 to 6 V DC	AQB1A2-ZT3/6VDC	AQB1A2-ZV3/6VDC
		7 to 14 V DC	AQB1A2-ZT7/14VDC	AQB1A2-ZV7/14VDC
		10 to 18 V DC	AQB1A2-ZT10/18VDC	AQB1A2-ZV10/18VDC
		18 to 30 V DC	AQB1A2-ZT18/30VDC	AQB1A2-ZV18/30VDC
Zero-cross 2 A	75 to 125 V AC	3 to 6 V DC	AQB2A1-ZT3/6VDC	—
		7 to 14 V DC	AQB2A1-ZT7/14VDC	—
		10 to 18 V DC	AQB2A1-ZT10/18VDC	—
		18 to 30 V DC	AQB2A1-ZT18/30VDC	—
	75 to 250 V AC	3 to 6 V DC	AQB2A2-ZT3/6VDC	AQB2A2-ZV3/6VDC
		7 to 14 V DC	AQB2A2-ZT7/14VDC	AQB2A2-ZV7/14VDC
		10 to 18 V DC	AQB2A2-ZT10/18VDC	AQB2A2-ZV10/18VDC
		18 to 30 V DC	AQB2A2-ZT18/30VDC	AQB2A2-ZV18/30VDC
Random 1 A	75 to 125 V AC	3 to 6 V DC	AQB1A1-T3/6VDC	—
		7 to 14 V DC	AQB1A1-T7/14VDC	—
		10 to 18 V DC	AQB1A1-T10/18VDC	—
		18 to 30 V DC	AQB1A1-T18/30VDC	—
	75 to 250 V AC	3 to 6 V DC	AQB1A2-T3/6VDC	AQB1A2-V3/6VDC
		7 to 14 V DC	AQB1A2-T7/14VDC	AQB1A2-V7/14VDC
		10 to 18 V DC	AQB1A2-T10/18VDC	AQB1A2-V10/18VDC
		18 to 30 V DC	AQB1A2-T18/30VDC	AQB1A2-V18/30VDC
Random 2 A	75 to 125 V AC	3 to 6 V DC	AQB2A1-T3/6VDC	—
		7 to 14 V DC	AQB2A1-T7/14VDC	—
		10 to 18 V DC	AQB2A1-T10/18VDC	—
		18 to 30 V DC	AQB2A1-T18/30VDC	—
	75 to 250 V AC	3 to 6 V DC	AQB2A2-T3/6VDC	AQB2A2-V3/6VDC
		7 to 14 V DC	AQB2A2-T7/14VDC	AQB2A2-V7/14VDC
		10 to 18 V DC	AQB2A2-T10/18VDC	AQB2A2-V10/18VDC
		18 to 30 V DC	AQB2A2-T18/30VDC	AQB2A2-V18/30VDC

ORDERING INFORMATION

Ex. AQB 1A 1 — ZT 3/6VDC

Load current	Load voltage	Type		Input voltage
1A 2A	1: 75 to 125 V AC 2: 75 to 250 V AC	ZT: Zero-cross type: 1,500 V T: Random type: 1,500 V	ZV: Zero-cross type: 4,000 V V: Random type: 4,000 V	3/6, 7/14, 10/18, 18/30 V DC

SPECIFICATIONS

Ratings (at 20°C 68°F, Input voltage ripple: 1% or less)

1. Zero-cross type

1 A type

Item	Part No.	AQB1A1-ZT	AQB1A1-ZT	AQB1A1-ZT	AQB1A1-ZT	AQB1A2-ZT	AQB1A2-ZT	AQB1A2-ZT	AQB1A2-ZT	Remarks	
		3/6VDC	7/14VDC	10/18VDC	18/30VDC	3/6VDC	7/14VDC	10/18VDC	18/30VDC		
Input side	Input voltage	3 to 6 V DC	7 to 14 V DC	10 to 18 V DC	18 to 30 V DC	3 to 6 V DC	7 to 14 V DC	10 to 18 V DC	18 to 30 V DC		
	Input impedance	Approx. 0.18 kΩ	Approx. 0.75 kΩ	Approx. 1.2 kΩ	Approx. 2.15 kΩ	Approx. 0.18 kΩ	Approx. 0.75 kΩ	Approx. 1.2 kΩ	Approx. 2.15 kΩ		
	Drop-out voltage, min.	1 V									
Load side	Max. load current	1 A									See "DATA 1"
	Load voltage	75 to 125 V AC				75 to 250 V AC					
	Frequency	45 to 65 Hz									
	Repetitive peak voltage, max.	400 V				600 V					
	Non-repetitive surge current	10A									In one cycle at 60 Hz
	"OFF-state" leakage current	0.6 mA/100 V applied				1.1 mA/200 V applied					at 60 Hz
	Max. "ON-state" voltage drop	1.6 V									at max. carrying current
	Min. load current	10 mA				20 mA					
	OFF state dV/dt	100 V/μs									

2 A type

Item	Part No.	AQB2A1-ZT	AQB2A1-ZT	AQB2A1-ZT	AQB2A1-ZT	AQB2A2-ZT	AQB2A2-ZT	AQB2A2-ZT	AQB2A2-ZT	Remarks	
		3/6VDC	7/14VDC	10/18VDC	18/30VDC	3/6VDC	7/14VDC	10/18VDC	18/30VDC		
Input side	Input voltage	3 to 6 V DC	7 to 14 V DC	10 to 18 V DC	18 to 30 V DC	3 to 6 V DC	7 to 14 V DC	10 to 18 V DC	18 to 30 V DC		
	Input impedance	Approx. 0.18 kΩ	Approx. 0.75 kΩ	Approx. 1.2 kΩ	Approx. 2.15 kΩ	Approx. 0.18 kΩ	Approx. 0.75 kΩ	Approx. 1.2 kΩ	Approx. 2.15 kΩ		
	Drop-out voltage, min.	1 V									
Load side	Max. load current	2 A									See "DATA 1"
	Load voltage	75 to 125 V AC				75 to 250 V AC					
	Frequency	45 to 65 Hz									
	Repetitive peak voltage, max.	400 V				600 V					
	Non-repetitive surge current	20A									In one cycle at 60 Hz
	"OFF-state" leakage current	0.6 mA/100 V applied				1.1 mA/200 V applied					at 60 Hz
	Max. "ON-state" voltage drop	1.6 V									at max. carrying current
	Min. load current	10 mA				20 mA					
	OFF state dV/dt	100 V/μs									

AQ-B

勝特力材料 886-3-5753170
 勝特力电子(上海) 86-21-54151736
 勝特力电子(深圳) 86-755-83298787
[Http://www.100y.com.tw](http://www.100y.com.tw)

2. Random type

1 A type

Item	Part No.	AQB1A1-T	AQB1A1-T	AQB1A1-T	AQB1A1-T	AQB1A2-T	AQB1A2-T	AQB1A2-T	AQB1A2-T	Remarks	
		3/6VDC	7/14VDC	10/18VDC	18/30VDC	3/6VDC	7/14VDC	10/18VDC	18/30VDC		
Input side	Input voltage	3 to 6 V DC	7 to 14 V DC	10 to 18 V DC	18 to 30 V DC	3 to 6 V DC	7 to 14 V DC	10 to 18 V DC	18 to 30 V DC		
	Input impedance	Approx. 0.18 kΩ	Approx. 0.75 kΩ	Approx. 1.2 kΩ	Approx. 2.15 kΩ	Approx. 0.18 kΩ	Approx. 0.75 kΩ	Approx. 1.2 kΩ	Approx. 2.15 kΩ		
Load side	Drop-out voltage, min.	1 V									
	Max.load current	1 A									See "DATA 1"
	Load voltage	75 to 125 V AC				75 to 250 V AC					
	Frequency	45 to 65 Hz									
	Repetitive peak voltage, max.	400 V				600 V					
	Non-repetitive surge current	10A									In one cycle at 60 Hz
	"OFF-state" leakage current	0.6 mA/100 V applied				1.1 mA/200 V applied					at 60 Hz
	Max. "ON-state" voltage drop	1.6 V									at max. carrying current
	Min. load current	10 mA				20 mA					
	OFF state dV/dt	100 V/μs									

2 A type

Item	Part No.	AQB2A1-T	AQB2A1-T	AQB2A1-T	AQB2A1-T	AQB2A2-T	AQB2A2-T	AQB2A2-T	AQB2A2-T	Remarks	
		3/6VDC	7/14VDC	10/18VDC	18/30VDC	3/6VDC	7/14VDC	10/18VDC	18/30VDC		
Input side	Input voltage	3 to 6 V DC	7 to 14 V DC	10 to 18 V DC	18 to 30 V DC	3 to 6 V DC	7 to 14 V DC	10 to 18 V DC	18 to 30 V DC		
	Input impedance	Approx. 0.18 kΩ	Approx. 0.75 kΩ	Approx. 1.2 kΩ	Approx. 2.15 kΩ	Approx. 0.18 kΩ	Approx. 0.75 kΩ	Approx. 1.2 kΩ	Approx. 2.15 kΩ		
Load side	Drop-out voltage, min.	1 V									
	Max.load current	2 A									See "DATA 1"
	Load voltage	75 to 125 V AC				75 to 250 V AC					
	Frequency	45 to 65 Hz									
	Repetitive peak voltage, max.	400 V				600 V					
	Non-repetitive surge current	20A									In one cycle at 60 Hz
	"OFF-state" leakage current	0.6 mA/100 V applied				1.1 mA/200 V applied					at 60 Hz
	Max. "ON-state" voltage drop	1.6 V									at max. carrying current
	Min. load current	10 mA				20 mA					
	OFF state dV/dt	100 V/μs									

Characteristics (at 20°C 68°F, Input voltage ripple: less than 1%)

Item	Zero-cross type		Random type		Remarks
	Standard type	Reinforced type	Standard type	Reinforced type	
Operate time, max.	(1/2 cycle of voltage sine wave) +1 ms		0.5 ms		
Release time, max.	(1/2 cycle of voltage sine wave) +1 ms				
Insulation resistance, min.	10 ⁹ Ω between input and output				
Breakdown voltage	1,500 V AC between input and output	4,000 V AC between input and output	1,500 V AC between input and output	4,000 V AC between input and output	For 1 minute
Vibration resistance	Functional	10 to 55 Hz at double amplitude of 3 mm			10 minutes for X, Y, Z axes
	Destructive	10 to 55 Hz at double amplitude of 3 mm			1 hour for X, Y, Z axes
Shock resistance	Functional	Min. 980 m/s ² {100 G}			4 times for X, Y, Z axes
	Destructive	Min. 980 m/s ² {100 G}			5 times for X, Y, Z axes
Ambient temperature	-20°C to +80°C -4°F to +176°F				
Storage temperature	-25°C to +85°C -13°F to +185°F				
Operational method	Zero-cross Turn-ON Zero-cross Turn-OFF		Random Turn-ON Zero-cross Turn-OFF		

OPERATING PRINCIPLE

Internal circuit
 Zero-cross type

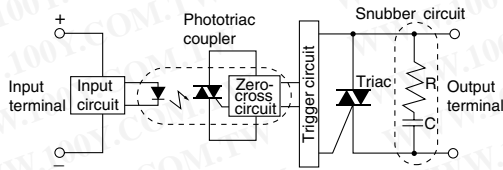

Random type

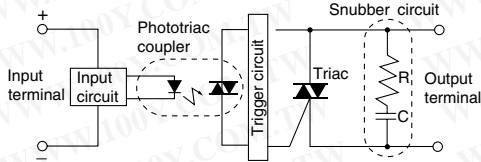

Wave form of input and output (Resistive load)

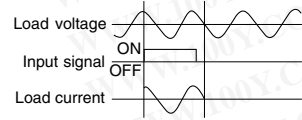
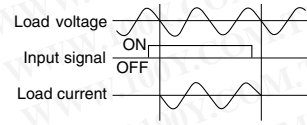

DIMENSIONS

(Common for zero-cross and Random type)

mm inch

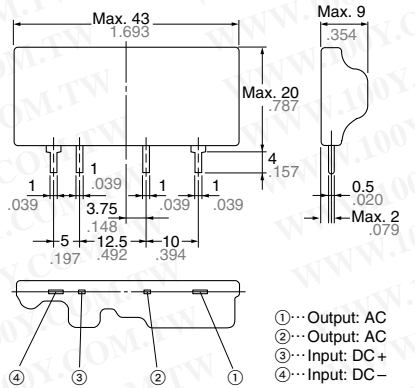
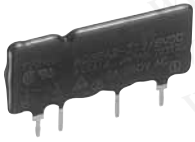

General tolerance: $\pm 0.5 \pm 0.20$

PC board pattern (BOTTOM VIEW)

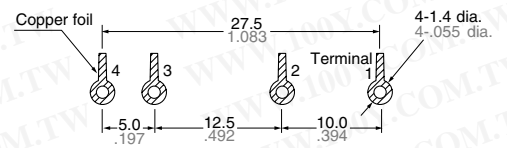

Terminal connection diagram

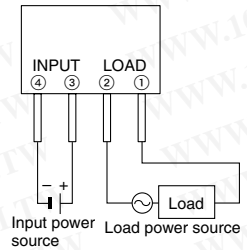

REFERENCE DATA

1. Load current vs. ambient temperature

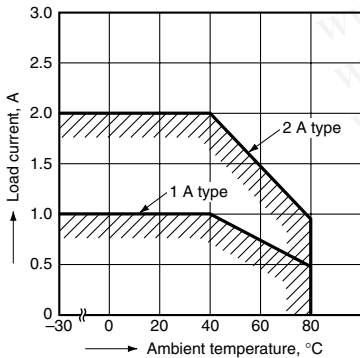

2-1. Non-repetitive surge current vs. carrying time (1 A type)

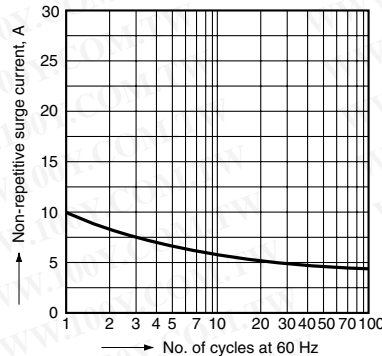

2-2. Non-repetitive surge current vs. carrying time (2 A type)

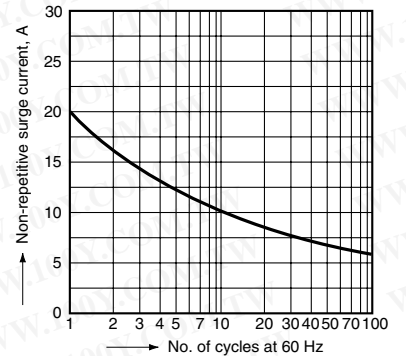

3. Input current vs. input voltage

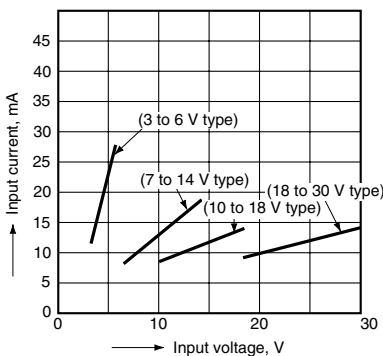

4. Load current vs. ambient temperature for adjacent mounting

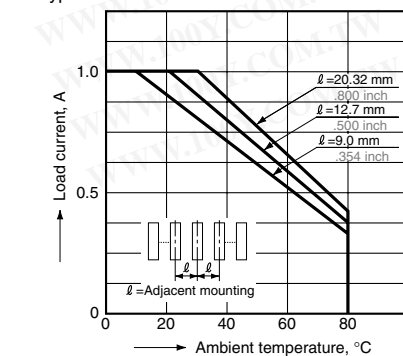

2 A type

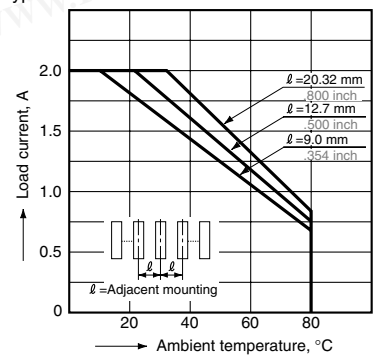

AQ-B

NOTE

When used for the load less than rated

In case of the load current less than rated, malfunction may result from the residual voltage across the both ends of the load even if the solid state relay is turned off.

Use a dummy resistor as a countermeasure.

The total of the current through the resistor and the load current must exceed the min. rated load current.

In case the dummy resistor is not used, keep in mind that the residual voltage becomes as follows:

Example:

For the inductive load by the 5 mA load current and the 200 V AC load voltage, the load impedance becomes 40 kΩ and $V_e/V = 16\%$ is estimated from the right above graph. Accordingly, the 32 V voltage remains across the both ends of the load when the solid state relay is turned off.

• Characteristics of residual voltage vs. load impedance

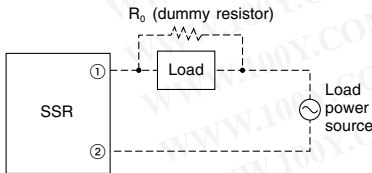
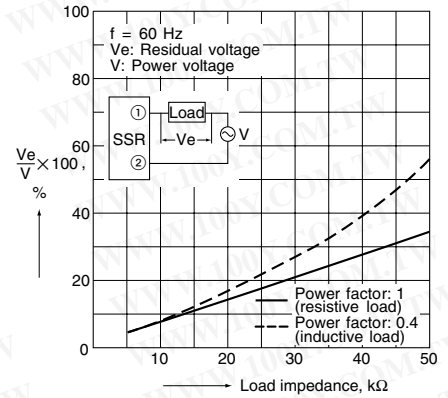

For Cautions for Use.

勝特力材料 886-3-5753170
勝特力电子(上海) 86-21-54151736
勝特力电子(深圳) 86-755-83298787
[Http://www.100y.com.tw](http://www.100y.com.tw)