



SC70, Single/Dual Low-Voltage, Low-Power μ P Reset Circuits

General Description

The MAX6381–MAX6390 microprocessor (μ P) supervisory circuits monitor power supply voltages from +1.8V to +5.0V while consuming only 3 μ A of supply current at +1.8V. Whenever V_{CC} falls below the factory-set reset thresholds, the reset output asserts and remains asserted for a minimum reset timeout period after V_{CC} rises above the reset threshold. Reset thresholds are available from +1.58V to +4.63V, in approximately 100mV increments. Seven minimum reset timeout delays ranging from 1ms to 1200ms are available.

The MAX6381/MAX6384/MAX6387 have a push-pull active-low reset output. The MAX6382/MAX6385/MAX6388 have a push-pull active-high reset output, and the MAX6383/MAX6386/MAX6389/MAX6390 have an open-drain active-low reset output. The MAX6384/MAX6385/MAX6386 also feature a debounced manual reset input (with internal pullup resistor). The MAX6387/MAX6388/MAX6389 have an auxiliary input for monitoring a second voltage. The MAX6390 offers a manual reset input with a longer V_{CC} reset timeout period (1120ms or 1200ms) and a shorter manual reset timeout (140ms or 150ms).

The MAX6381/MAX6382/MAX6383 are available in 3-pin SC70 packages and the MAX6384–MAX6390 are available in 4-pin SC70 packages.

Applications

Computers
 Controllers
 Intelligent Instruments
 Critical μ P and μ C Power Monitoring
 Portable/Battery-Powered Equipment
 Dual Voltage Systems

Pin Configurations

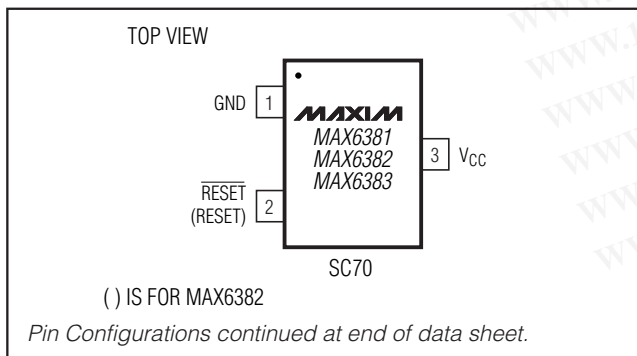

Features

- ◆ Factory-Set Reset Threshold Voltages Ranging from +1.58V to +4.63V in Approximately 100mV Increments
- ◆ $\pm 2.5\%$ Reset Threshold Accuracy Over Temperature (-40°C to $+125^{\circ}\text{C}$)
- ◆ Seven Reset Timeout Periods Available: 1ms, 20ms, 140ms, 280ms, 560ms, 1120ms, 1200ms (min)
- ◆ 3 Reset Output Options
 - Active-Low Push-Pull
 - Active-High Push-Pull
 - Active-Low Open-Drain
- ◆ Reset Output State Guaranteed Valid Down to $V_{CC} = 1\text{V}$
- ◆ Manual Reset Input (MAX6384/MAX6385/MAX6386)
- ◆ Auxiliary RESET IN (MAX6387/MAX6388/MAX6389)
- ◆ V_{CC} Reset Timeout (1120ms or 1200ms)/Manual Reset Timeout (140ms or 150ms) (MAX6390)
- ◆ Negative-Going V_{CC} Transient Immunity
- ◆ Low Power Consumption of 6 μA at +3.6V and 3 μA at +1.8V
- ◆ Pin Compatible with MAX809/MAX810/MAX803/MAX6326/MAX6327/MAX6328/MAX6346/MAX6347/MAX6348, and MAX6711/MAX6712/MAX6713
- ◆ Tiny 3-Pin SC70 and 4-Pin SC70 Packages

Ordering Information

PART	TEMP RANGE	PIN-PACKAGE
MAX6381XR_ _D_-T	-40°C to $+125^{\circ}\text{C}$	3 SC70-3
MAX6382XR_ _D_-T	-40°C to $+125^{\circ}\text{C}$	3 SC70-3
MAX6383XR_ _D_-T	-40°C to $+125^{\circ}\text{C}$	3 SC70-3

Note: Insert reset threshold suffix (see Reset Threshold table) after "XR" or "XS". Insert reset timeout delay (see Reset Timeout Delay table) after "D" to complete the part number. Sample stock is generally held on standard versions only (see Standard Versions table). Standard versions have an order increment requirement of 2500 pieces. Nonstandard versions have an order increment requirement of 10,000 pieces. Contact factory for availability of nonstandard versions.

Devices are available in both leaded and lead-free packaging. Specify lead-free by replacing "-T" with "+T" when ordering.

Ordering Information continued at end of data sheet.
 Typical Operating Circuit appears at end of data sheet.
 Selector Guide appears at end of data sheet.

SC70, Single/Dual Low-Voltage, Low-Power μ P Reset Circuits

勝特力材料 886-3-5753170
 勝特力电子(上海) 86-21-54151736
 勝特力电子(深圳) 86-755-83298787
[Http://www.100y.com.tw](http://www.100y.com.tw)

ABSOLUTE MAXIMUM RATINGS

V_{CC} to GND	-0.3V to +6.0V	Continuous Power Dissipation ($T_A = +70^\circ\text{C}$)	
RESET Open-Drain Output	-0.3V to +6.0V	3-Pin SC70 (derate 2.9mW/ $^\circ\text{C}$ above $+70^\circ\text{C}$)	235mW
RESET, RESET (push-pull output)	-0.3V to ($V_{CC} + 0.3\text{V}$)	4-Pin SC70 (derate 3.1mW/ $^\circ\text{C}$ above $+70^\circ\text{C}$)	245mW
MR, RESET IN	-0.3V to ($V_{CC} + 0.3\text{V}$)	Operating Temperature Range	-40°C to $+125^\circ\text{C}$
Input Current (V_{CC})	.20mA	Storage Temperature Range	-65°C to $+150^\circ\text{C}$
Output Current (all pins)	.20mA	Lead Temperature (soldering, 10s)	$+300^\circ\text{C}$

Stresses beyond those listed under "Absolute Maximum Ratings" may cause permanent damage to the device. These are stress ratings only, and functional operation of the device at these or any other conditions beyond those indicated in the operational sections of the specifications is not implied. Exposure to absolute maximum rating conditions for extended periods may affect device reliability.

ELECTRICAL CHARACTERISTICS

(V_{CC} = full range, $T_A = -40^\circ\text{C}$ to $+125^\circ\text{C}$, unless otherwise specified. Typical values are at $T_A = +25^\circ\text{C}$.) (Note 1)

PARAMETER	SYMBOL	CONDITIONS	MIN	TYP	MAX	UNITS
Operating Voltage Range	V_{CC}		1.0		5.5	V
V_{CC} Supply Current	I_{CC}	$V_{CC} = 5.5\text{V}$, no load		7	13	μA
		$V_{CC} = 3.6\text{V}$, no load		6	11	
		$V_{CC} = 2.5\text{V}$, no load		4	7	
		$V_{CC} = 1.8\text{V}$, no load		3	6	
V_{CC} Reset Threshold (See Reset Thresholds table)	V_{TH}	$T_A = +25^\circ\text{C}$	$V_{TH} - 1.5\%$	V_{TH}	$V_{TH} + 1.5\%$	V
		$T_A = -40^\circ\text{C}$ to $+125^\circ\text{C}$	$V_{TH} - 2.5\%$	V_{TH}	$V_{TH} + 2.5\%$	
Reset Threshold Tempco	$\Delta V_{TH}/^\circ\text{C}$			60		ppm/ $^\circ\text{C}$
V_{CC} to Reset Delay		V_{CC} falling at $10\text{mV}/\mu\text{s}$ from $V_{TH} + 100\text{mV}$ to $V_{TH} - 100\text{mV}$		35		μs
Reset Timeout Period MAX6381-MAX6389 (See Reset Timeout table)	t_{RP}	D1	1		2	ms
		D2	20		40	
		D3	140		280	
		D5	280		560	
		D6	560		1120	
		D4	1120		2240	
		D7	1200		2400	
Reset Timeout Period MAX6390	t_{RP}	MR timeout period	D4	140	280	ms
			D7	150	300	
		V_{CC} timeout period	D4	1120	2240	
			D7	1200	2400	
MR Input Voltage	V_{IL}	$V_{TH} < 4\text{V}$			$0.3 \times V_{CC}$	V
	V_{IH}			$0.7 \times V_{CC}$		
	V_{IL}	$V_{TH} > 4\text{V}$			0.8	
	V_{IH}			2.4		

勝特力材料 886-3-5753170
 勝特力电子(上海) 86-21-54151736
 勝特力电子(深圳) 86-755-83298787
[Http://www.100y.com.tw](http://www.100y.com.tw)

SC70, Single/Dual Low-Voltage, Low-Power μ P Reset Circuits

MAX6381-MAX6390

ELECTRICAL CHARACTERISTICS (continued)

(V_{CC} = full range, T_A = -40°C to $+125^{\circ}\text{C}$, unless otherwise specified. Typical values are at T_A = $+25^{\circ}\text{C}$.) (Note 1)

PARAMETER	SYMBOL	CONDITIONS	MIN	TYP	MAX	UNITS
$\overline{\text{MR}}$ Minimum Input Pulse Width			1			μs
$\overline{\text{MR}}$ Glitch Rejection				100		ns
$\overline{\text{MR}}$ to Reset Delay				200		ns
$\overline{\text{MR}}$ Internal Pullup Resistance		MAX6381-MAX6389	32	63	100	$\text{k}\Omega$
		MAX6390	500	1560	3000	Ω
RESET IN Input Threshold	V_{THRST}	T_A = $+25^{\circ}\text{C}$	1.245	1.27	1.295	V
		T_A = 0°C to $+85^{\circ}\text{C}$	1.232		1.308	
		T_A = -40°C to $+125^{\circ}\text{C}$	1.219		1.321	
RESET IN to RESET Delay		V_{RESETIN} falling at $4\text{mV}/\mu\text{s}$ from $V_{\text{THRST}} + 40\text{mV}$ to $V_{\text{THRST}} - 40\text{mV}$		4.5		μs
RESET IN Input Leakage Current	$I_{\text{RESET IN}}$		-50	± 1	+50	nA
Open-Drain $\overline{\text{RESET}}$ Output Voltage	V_{OL}	$V_{\text{CC}} \geq 4.5\text{V}$, $I_{\text{SINK}} = 3.2\text{mA}$, reset asserted			0.4	V
		$V_{\text{CC}} \geq 2.5\text{V}$, $I_{\text{SINK}} = 1.2\text{mA}$, reset asserted			0.3	
		$V_{\text{CC}} \geq 1.0\text{V}$, $I_{\text{SINK}} = 80\mu\text{A}$, reset asserted			0.3	
Open-Drain $\overline{\text{RESET}}$ Output Leakage Current	I_{LKG}	$V_{\text{CC}} > V_{\text{TH}}$, $\overline{\text{RESET}}$ not asserted			1.0	μA
Push-Pull $\overline{\text{RESET}}$ Output Voltage	V_{OL}	$V_{\text{CC}} \geq 4.5\text{V}$, $I_{\text{SINK}} = 3.2\text{mA}$, reset asserted			0.4	V
		$V_{\text{CC}} \geq 2.5\text{V}$, $I_{\text{SINK}} = 1.2\text{mA}$, reset asserted			0.3	
		$V_{\text{CC}} \geq 1.0\text{V}$, $I_{\text{SINK}} = 80\mu\text{A}$, reset asserted			0.3	
	V_{OH}	$V_{\text{CC}} \geq 4.5\text{V}$, $I_{\text{SOURCE}} = 800\mu\text{A}$, reset not asserted	$0.8 \times V_{\text{CC}}$			
		$V_{\text{CC}} \geq 2.5\text{V}$, $I_{\text{SOURCE}} = 500\mu\text{A}$, reset not asserted	$0.8 \times V_{\text{CC}}$			
		$V_{\text{CC}} \geq 1.0\text{V}$, $I_{\text{SOURCE}} = 1\mu\text{A}$, reset asserted	$0.8 \times V_{\text{CC}}$			
Push-Pull RESET Output Voltage	V_{OH}	$V_{\text{CC}} \geq 4.5\text{V}$, $I_{\text{SOURCE}} = 800\mu\text{A}$, reset asserted	$0.8 \times V_{\text{CC}}$			
		$V_{\text{CC}} \geq 2.5\text{V}$, $I_{\text{SOURCE}} = 500\mu\text{A}$, reset asserted	$0.8 \times V_{\text{CC}}$			
		$V_{\text{CC}} \geq 1.8\text{V}$, $I_{\text{SOURCE}} = 150\mu\text{A}$, reset asserted	$0.8 \times V_{\text{CC}}$			
		$V_{\text{CC}} \geq 1.0\text{V}$, $I_{\text{SOURCE}} = 1\mu\text{A}$, reset asserted	$0.8 \times V_{\text{CC}}$			
	V_{OL}	$V_{\text{CC}} \geq 4.5\text{V}$, $I_{\text{SINK}} = 3.2\text{mA}$, reset not asserted			0.4	
		$V_{\text{CC}} \geq 2.5\text{V}$, $I_{\text{SINK}} = 1.2\text{mA}$, reset not asserted			0.3	

Note 1: Specifications over temperature are guaranteed by design, not production tested.

SC70, Single/Dual Low-Voltage, Low-Power μ P Reset Circuits

勝特力材料 886-3-5753170
 勝特力电子(上海) 86-21-54151736
 勝特力电子(深圳) 86-755-83298787
[Http://www.100y.com.tw](http://www.100y.com.tw)

Typical Operating Characteristics

($T_A = +25^\circ\text{C}$, unless otherwise noted.)

SUPPLY CURRENT vs. TEMPERATURE (NO LOAD)

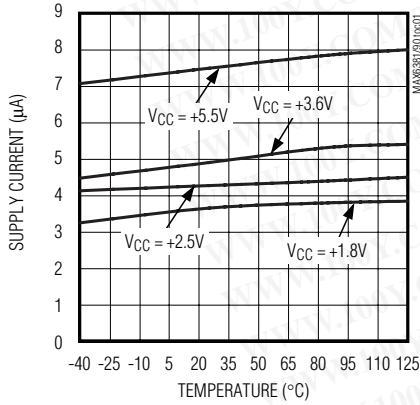

POWER-DOWN RESET DELAY vs. TEMPERATURE

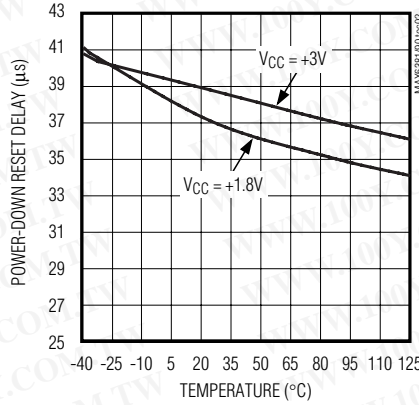

NORMALIZED POWER-UP RESET TIMEOUT vs. TEMPERATURE

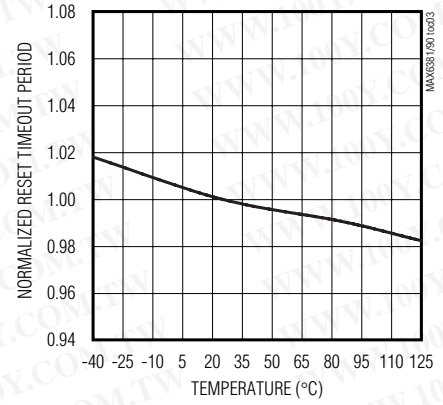

NORMALIZED RESET THRESHOLD vs. TEMPERATURE

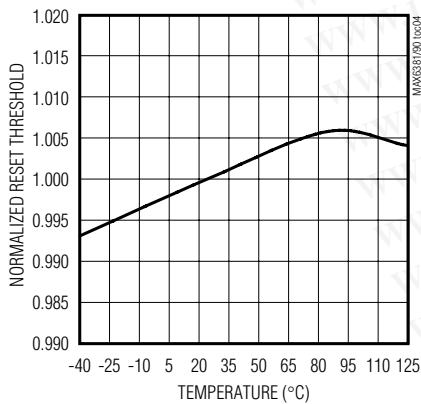

OUTPUT-VOLTAGE LOW vs. SINK CURRENT

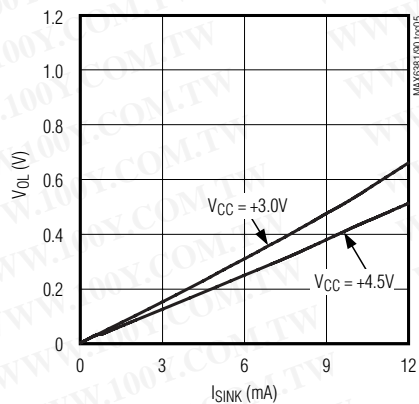

OUTPUT-VOLTAGE HIGH vs. SOURCE CURRENT

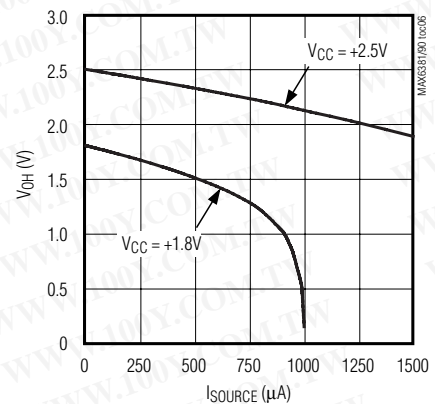

MAXIMUM TRANSIENT DURATION vs. RESET COMPARATOR OVERDRIVE

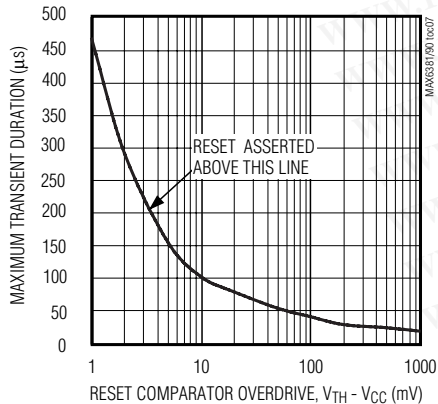

RESET IN TO RESET DELAY vs. TEMPERATURE

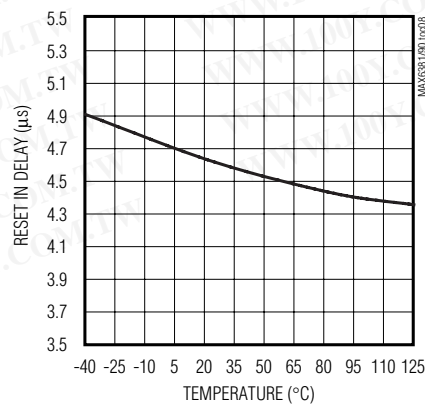

勝特力材料 886-3-5753170
 勝特力电子(上海) 86-21-54151736
 勝特力电子(深圳) 86-755-83298787
 Http://www.100y.com.tw

SC70, Single/Dual Low-Voltage, Low-Power μ P Reset Circuits

Pin Description

PIN						NAME	FUNCTION
MAX6381/ MAX6383	MAX6382	MAX6384/ MAX6386/ MAX6390	MAX6385	MAX6387/ MAX689	MAX6388		
1	1	1	1	1	1	GND	Ground
—	2	—	2	—	2	RESET	Active-High Push-Pull Reset Output. RESET changes from low to high when any monitored voltage (V_{CC} or $V_{RESETIN}$) drops below the reset threshold or \overline{MR} is pulled low. RESET remains high for the reset timeout period after monitored voltages exceed the reset thresholds or \overline{MR} is released.
2	—	2	—	2	—	\overline{RESET}	Active-Low Open-Drain/Push-Pull Reset Output. \overline{RESET} changes from high to low when any monitored voltage (V_{CC} or $V_{RESETIN}$) drops below the reset threshold or \overline{MR} is pulled low. \overline{RESET} remains low for the reset timeout period after the monitored voltages exceed the reset thresholds or \overline{MR} is released. Open-drain requires an external pullup resistor.
—	—	3	3	—	—	\overline{MR}	Active-Low Manual Reset Input. Drive low to force a reset. Reset remains active as long as \overline{MR} is low and for the reset timeout period after \overline{MR} is released. Leave unconnected or connect to V_{CC} if unused. \overline{MR} has an internal 63k Ω (1.56k Ω for MAX6390) pullup resistor to V_{CC} .
—	—	—	—	3	3	RESET IN	Auxiliary Reset Input. High-impedance input to the auxiliary reset comparator. Connect RESET IN to the center point of an external resistor voltage-divider network to set the reset threshold voltage. Reset asserts when either V_{CC} or RESET IN falls below its threshold voltage.
3	3	4	4	4	4	V_{CC}	Supply Voltage for the device and input for fixed V_{CC} reset threshold monitor.

MAX6381-MAX6390

SC70, Single/Dual Low-Voltage, Low-Power μ P Reset Circuits

勝特力材料 886-3-5753170
 勝特力电子(上海) 86-21-54151736
 勝特力电子(深圳) 86-755-83298787
[Http://www.100y.com.tw](http://www.100y.com.tw)

Detailed Description

RESET Output

A μ P reset input starts the μ P in a known state. These μ P supervisory circuits assert reset to prevent code execution errors during power-up, power-down, or brownout conditions.

Reset asserts when V_{CC} is below the reset threshold; once V_{CC} exceeds the reset threshold, an internal timer keeps the reset output asserted for the reset timeout period. After this interval, reset output deasserts. Reset output is guaranteed to be in the correct logic state for $V_{CC} \geq 1V$.

Manual Reset Input (MAX6384/MAX6385/MAX6386/MAX6390)

Many μ P-based products require manual reset capability, allowing the operator, a test technician, or external logic circuitry to initiate a reset. A logic low on MR asserts reset. Reset remains asserted while \overline{MR} is low, and for the reset active timeout period (t_{RP}) after \overline{MR} returns high. This input has an internal 63k Ω pullup resistor (1.56k Ω for MAX6390), so it can be left unconnected if it is not used. MR can be driven with TTL or CMOS logic levels, or with open-drain/collector outputs. Connect a normally open momentary switch from \overline{MR} to GND to create a manual-reset function; external debounce circuitry is not required. If MR is driven from long cables or if the device is used in a noisy environment, connecting a 0.1 μ F capacitor from \overline{MR} to GND provides additional noise immunity.

RESET IN Comparator (MAX6387/MAX6388/MAX6389)

RESET IN is compared to an internal +1.27V reference. If the voltage at RESET IN is less than 1.27V, reset asserts. Use the RESET IN comparator as a user-adjustable reset detector or as a secondary power-supply monitor by implementing a resistor-divider at RESET IN (shown in Figure 1). Reset asserts when either V_{CC} or RESET IN falls below its respective threshold voltage. Use the following equation to set the threshold:

$$V_{INTH} = V_{THRST} (R1/R2 + 1)$$

where $V_{THRST} = +1.27V$. To simplify the resistor selection, choose a value of R2 and calculate R1:

$$R1 = R2 [(V_{INTH}/V_{THRST}) - 1]$$

Since the input current at RESET IN is 50nA (max), large values can be used for R2 with no significant loss in accuracy.

Reset Thresholds (-40°C to +125°C)

SUFFIX	V _{TH} (min)	V _{TH} (nom)	V _{TH} (max)
46	4.51	4.63	4.74
45	4.39	4.50	4.61
44	4.27	4.38	4.48
43	4.19	4.30	4.41
42	4.10	4.20	4.31
41	4.00	4.10	4.20
40	3.90	4.00	4.10
39	3.80	3.90	4.00
38	3.71	3.80	3.90
37	3.61	3.70	3.79
36	3.51	3.60	3.69
35	3.41	3.50	3.59
34	3.32	3.40	3.49
33	3.22	3.30	3.38
32	3.12	3.20	3.28
31	3.00	3.08	3.15
30	2.93	3.00	3.08
29	2.85	2.93	3.00
28	2.73	2.80	2.87
27	2.63	2.70	2.77
26	2.56	2.63	2.69
25	2.44	2.50	2.56
24	2.34	2.40	2.46
23	2.26	2.31	2.37
22	2.13	2.19	2.24
21	2.05	2.10	2.15
20	1.95	2.00	2.05
19	1.85	1.90	1.95
18	1.76	1.80	1.85
17	1.62	1.67	1.71
16	1.54	1.58	1.61

Applications Information

Negative-Going V_{CC} Transients

In addition to issuing a reset to the μ P during power-up, power-down, and brownout conditions, the MAX6381-MAX6390 are relatively immune to short duration negative-going V_{CC} transients (glitches).

The *Typical Operating Characteristics* section shows the Maximum Transient Durations vs. Reset Comparator Overdrive, for which the MAX6381-MAX6390 do not generate a reset pulse. This graph was generated using

SC70, Single/Dual Low-Voltage, Low-Power μ P Reset Circuits

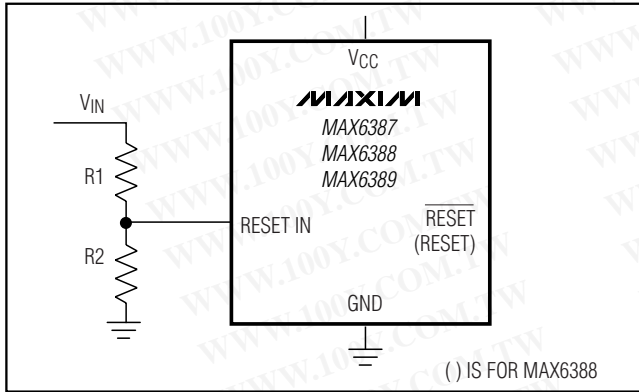

Figure 1. RESET IN Configuration

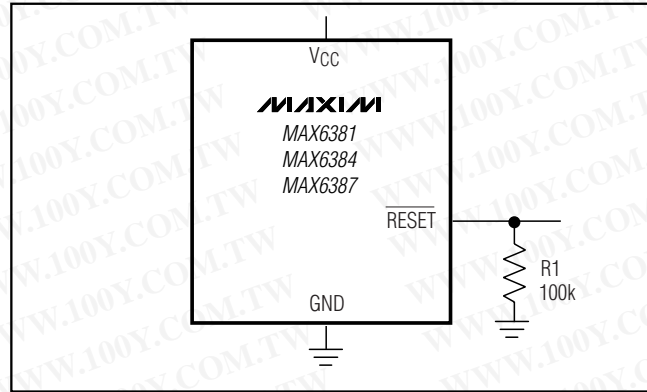

Figure 2. RESET Valid to $V_{CC} = \text{Ground}$ Circuit

Reset Timeout Delay

SUFFIX	MIN
D1	1ms
D2	20ms
D3	140ms
D5	280ms
D6	560ms
D4	1120ms
D7	1200ms
MAX6390XSD4	1120/140ms*
MAX6390XSD7	1200/150ms*

*The MAX6390 has a 1120ms or 1200ms $\overline{\text{RESET}}$ timeout and a 140ms or 150ms manual reset timeout.

a negative-going pulse applied to V_{CC} , starting above the actual reset threshold and ending below it by the magnitude indicated (reset comparator overdrive). The graph indicates the typical maximum pulse width a negative-going V_{CC} transient may have without causing a reset pulse to be issued. As the magnitude of the transient increases (goes farther below the reset threshold), the maximum allowable pulse width decreases. A 0.1 μ F capacitor mounted as close as possible to V_{CC} provides additional transient immunity.

Ensuring a Valid RESET Output Down to $V_{CC} = 0$

The MAX6381–MAX6390 are guaranteed to operate properly down to $V_{CC} = 1V$. In applications that require valid reset levels down to $V_{CC} = 0$, a pull-down resistor to active-low outputs (push/pull only, Figure 2) and a pullup resistor to active-high outputs (push/pull only) will ensure that the reset line is valid while the reset output can no longer sink or source current. This scheme

does not work with the open-drain outputs of the MAX6383/MAX6386/MAX6389/MAX6390. The resistor value used is not critical, but it must be small enough not to load the reset output when V_{CC} is above the reset threshold. For most applications, 100k Ω is adequate.

Standard Versions

PART	RESET THRESHOLD	RESET TIMEOUT
MAX638_	46	D3
	44	
	31	
	29	
	26	
	23	
	22	
	17	
MAX6390	46	D4
	44	
	31	
	29	
	26	
	23	
	22	
	17	

SC70, Single/Dual Low-Voltage, Low-Power μ P Reset Circuits

勝特力材料 886-3-5753170
 勝特力电子(上海) 86-21-54151736
 勝特力电子(深圳) 86-755-83298787
[Http://www.100y.com.tw](http://www.100y.com.tw)

Selector Guide

PART NUMBER	PUSH-PULL ACTIVE-LOW	PUSH-PULL ACTIVE-HIGH	OPEN-DRAIN ACTIVE-LOW	MANUAL RESET INPUT MR	RESET IN
MAX6381	X				
MAX6382		X			
MAX6383			X		
MAX6384	X			X	
MAX6385		X		X	
MAX6386			X	X	
MAX6390*			X	X	
MAX6387	X				X
MAX6388		X			X
MAX6389			X		X

*The MAX6390 offers a V_{CC} reset timeout of 1120ms or 1200ms (min) and a manual reset timeout of 140ms or 150ms (min).

Typical Operating Circuit

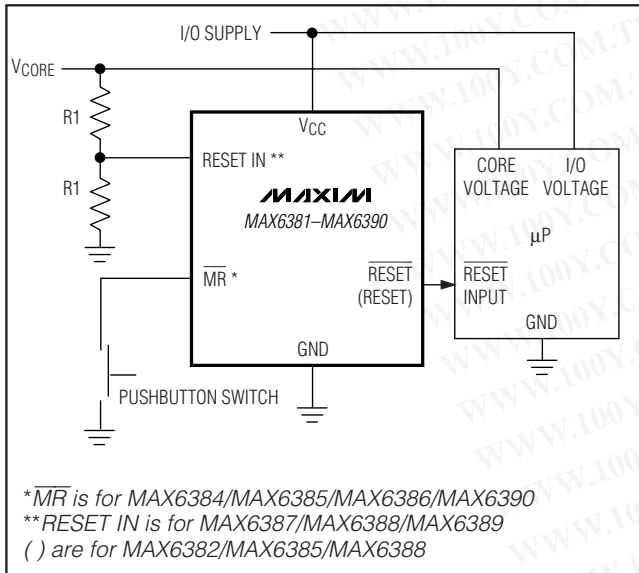

Pin Configurations (continued)

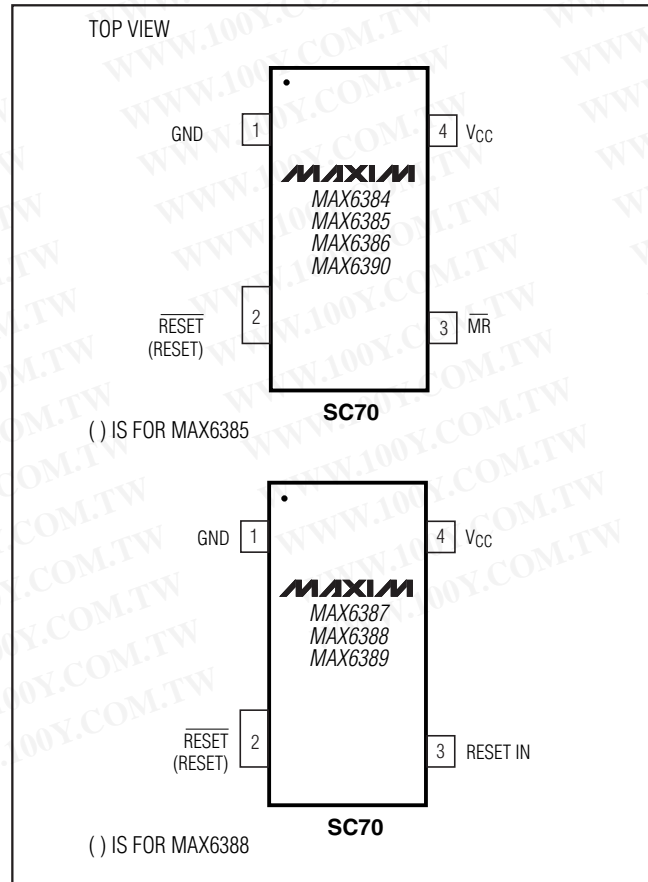

Chip Information

TRANSISTOR COUNT: 647
 PROCESS: BiCMOS

勝特力材料 886-3-5753170
 勝特力电子(上海) 86-21-54151736
 勝特力电子(深圳) 86-755-83298787
[Http://www.100y.com.tw](http://www.100y.com.tw)

SC70, Single/Dual Low-Voltage, Low-Power μ P Reset Circuits

Ordering Information (continued)

PART	TEMP RANGE	PIN-PACKAGE
MAX6384XS__D_-T	-40°C to +125°C	4 SC70-4
MAX6385XS__D_-T	-40°C to +125°C	4 SC70-4
MAX6386XS__D_-T	-40°C to +125°C	4 SC70-4
MAX6387XS__D_-T	-40°C to +125°C	4 SC70-4
MAX6388XS__D_-T	-40°C to +125°C	4 SC70-4
MAX6389XS__D_-T	-40°C to +125°C	4 SC70-4
MAX6390XS__D_-T*	-40°C to +125°C	4 SC70-4

Note: Insert reset threshold suffix (see Reset Threshold table) after "XR" or "XS". Insert reset timeout delay (see Reset Timeout Delay table) after "D" to complete the part number. Sample stock is generally held on standard versions only (see Standard Versions table). Standard versions have an order increment requirement of 2500 pieces. Nonstandard versions have an order increment requirement of 10,000 pieces. Contact factory for availability of nonstandard versions.

*MAX6390 is available with D4 or D7 timing only.

Devices are available in both leaded and lead-free packaging. Specify lead-free by replacing "-T" with "+T" when ordering.

MAX6381-MAX6390

勝特力材料 886-3-5753170
 勝特力电子(上海) 86-21-54151736
 勝特力电子(深圳) 86-755-83298787
 Http://www.100y.com.tw

SC70, Single/Dual Low-Voltage, Low-Power μ P Reset Circuits

Package Information

(The package drawing(s) in this data sheet may not reflect the most current specifications. For the latest package outline information, go to www.maxim-ic.com/packages.)

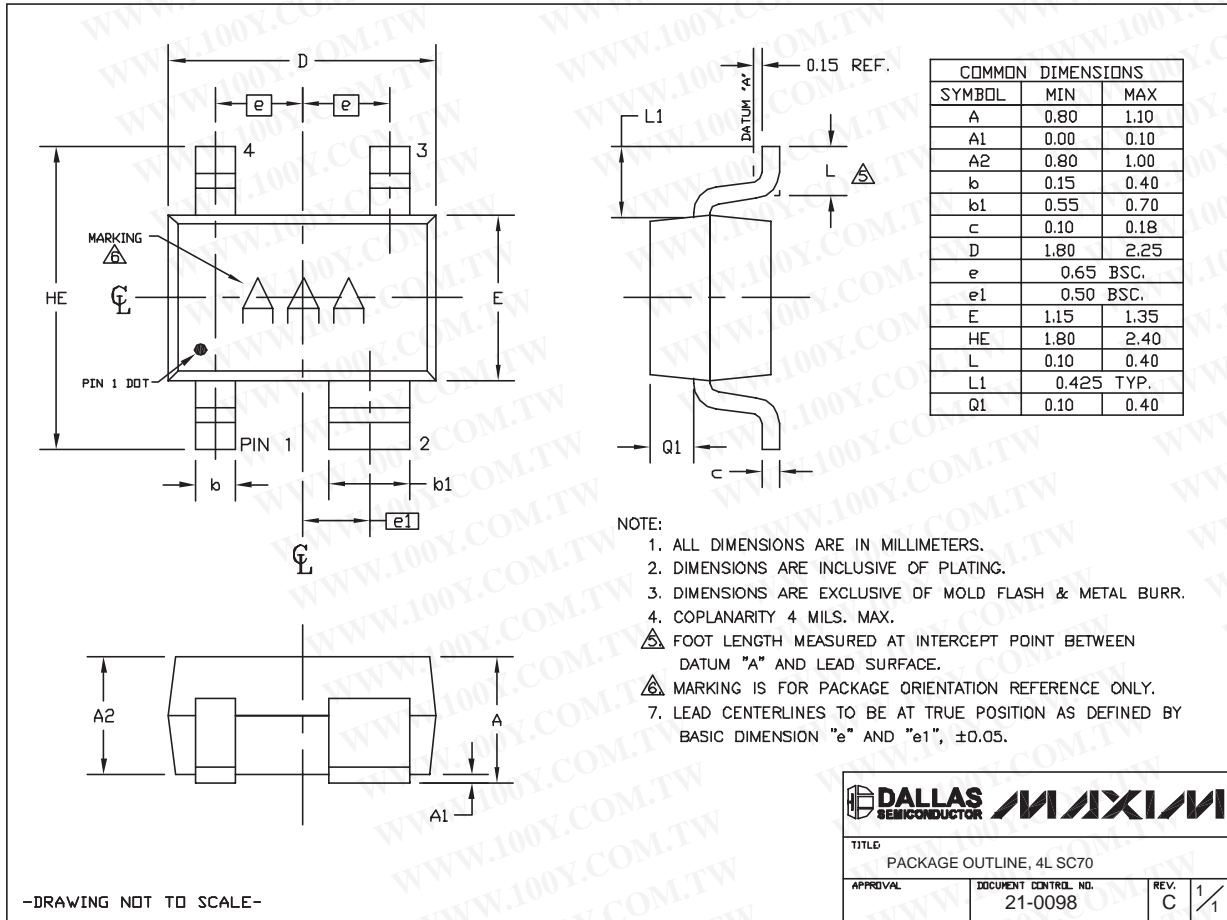

SC70, 4L-EPS

勝特力材料 886-3-5753170

勝特力电子(上海) 86-21-54151736

勝特力电子(深圳) 86-755-83298787

Http://www.100y.com.tw

SC70, Single/Dual Low-Voltage, Low-Power μ P Reset Circuits

Package Information (continued)

(The package drawing(s) in this data sheet may not reflect the most current specifications. For the latest package outline information, go to www.maxim-ic.com/packages.)

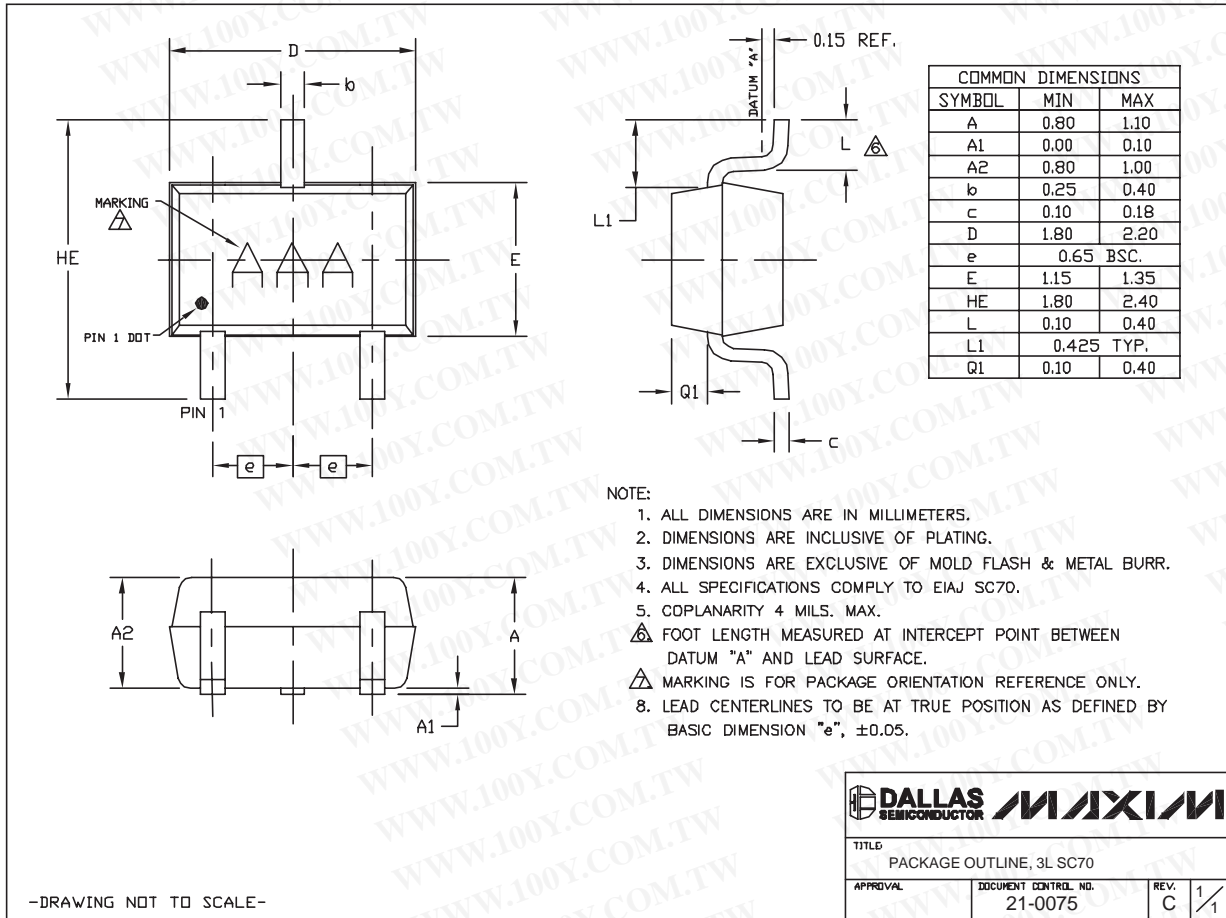

SC70, 3L, EPS

Maxim cannot assume responsibility for use of any circuitry other than circuitry entirely embodied in a Maxim product. No circuit patent licenses are implied. Maxim reserves the right to change the circuitry and specifications without notice at any time.

Maxim Integrated Products, 120 San Gabriel Drive, Sunnyvale, CA 94086 408-737-7600

11