

勝特力材料 886-3-5753170
勝特力电子(上海) 86-21-54151736
勝特力电子(深圳) 86-755-83298787
[Http://www.100y.com.tw](http://www.100y.com.tw)

Advance Information

33661

LIN Enhanced Physical Interface

Local Interconnect Network (LIN) is a serial communication protocol designed to support automotive networks in conjunction with Controller Area Network (CAN). As the lowest level of a hierarchical network, LIN enables cost-effective communication with sensors and actuators when all the features of CAN are not required.

The 33661 is a Physical Layer component dedicated to automotive LIN sub-bus applications. It offers slew rate selection for optimized operation at 10 kbps and 20 kbps, fast baud rate (above 100 kbps) for test and programming modes, excellent radiated emission performance, and safe behavior in the event of LIN bus short-to-ground or LIN bus leakage during low-power mode.

Features

- Operational from V_{SUP} 6.0 V to 18 V DC, Functional up to 27 V DC, and Handles 40 V During Load Dump
- Active Bus Waveshaping Offering Excellent Radiated Emission Performance
- 5.0 kV ESD on LIN Bus Terminal
- 30 k Ω Internal Pullup Resistor
- LIN Bus Short-to-Ground or High Leakage in Sleep Mode
- 18 V to +40 V DC Voltage at LIN Terminal
- 8.0 μ A Standby Current in Sleep Mode
- Local and Remote Wake-Up Capability Reported by INH and RXD Terminals
- 5.0 V and 3.3 V Compatible Digital Inputs Without Any External Components Required

LIN INTERFACE

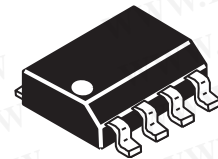

D SUFFIX
CASE 751-06
8-TERMINAL SOICN

ORDERING INFORMATION

Device	Temperature Range (T_A)	Package
MC33661D/R2	-40°C to 125°C	8 SOICN

33661 Simplified Application Diagram

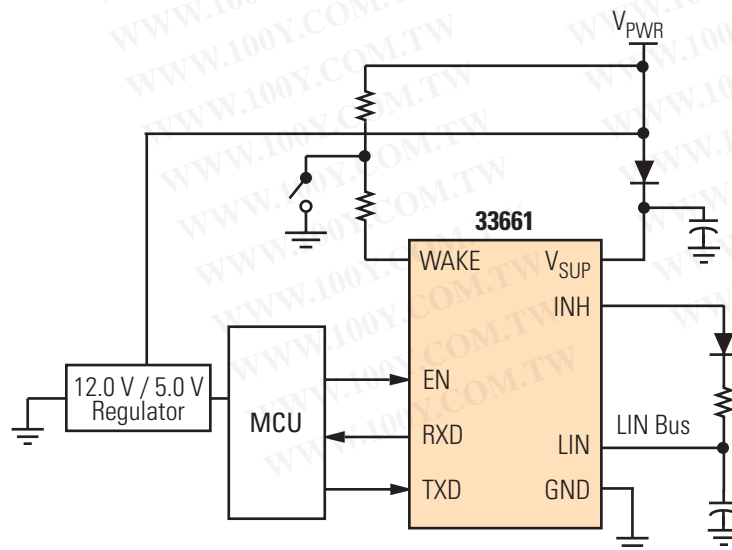

This document contains certain information on a new product. Specifications and information herein are subject to change without notice.

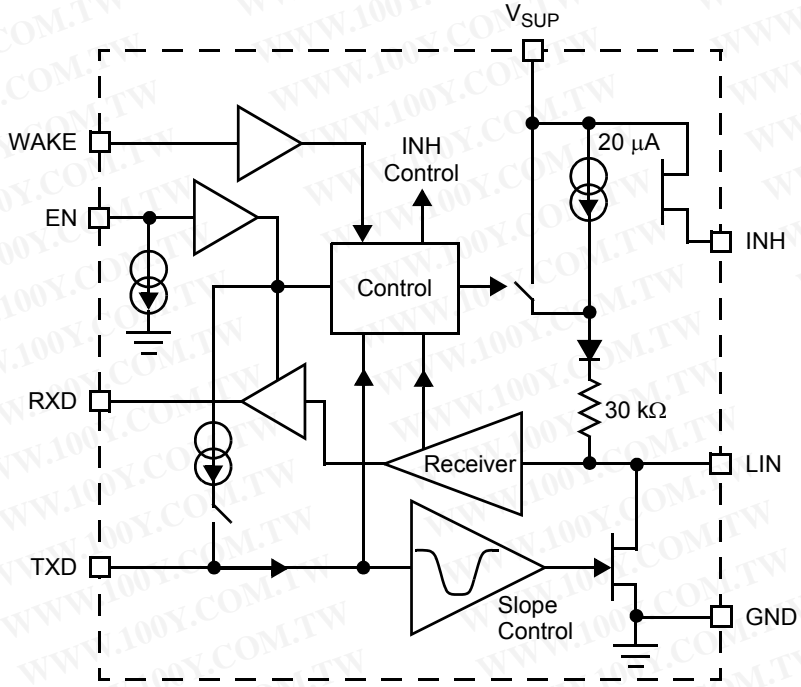
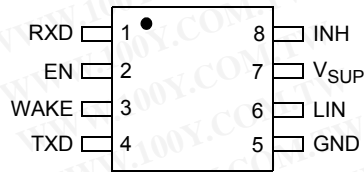

Figure 1. 33661 Simplified Internal Block Diagram

勝特力材料 886-3-5753170
勝特力电子(上海) 86-21-54151736
勝特力电子(深圳) 86-755-83298787
[Http://www.100y.com.tw](http://www.100y.com.tw)

Freescale Semiconductor, Inc.



TERMINAL DEFINITIONS

A functional description of each terminal can be found in the System/Application Information section beginning on [page 13](#).

Terminal	Terminal Name	Formal Name	Definition
1	RXD	Receiver Output	MCU interface that reports the state of the LIN bus voltage.
2	EN	Enable Control	Controls the operation mode of the interface.
3	WAKE	Wake Input	A high-voltage input used to wake up the device from sleep mode.
4	TXD	Transmitter Input	MCU interface to control the state of the LIN output.
5	INH	Inhibit Output	This terminal can have two main functions: controlling an external switchable voltage regulator or driving a bus external resistor in the master node application.
6	V _{SUP}	Power Supply	Device power supply terminal.
7	LIN	LIN Bus	Represents the single-wire bus transmitter and receiver.
8	GND	Ground	Device ground terminal.

勝特力材料 886-3-5753170
 勝特力电子(上海) 86-21-54151736
 勝特力电子(深圳) 86-755-83298787
[Http://www.100y.com.tw](http://www.100y.com.tw)

Freescale Semiconductor, Inc.

MAXIMUM RATINGS

All voltages are with respect to ground unless otherwise noted. Exceeding these ratings may cause a malfunction or permanent damage to the device.

Ratings	Symbol	Value	Unit
---------	--------	-------	------

ELECTRICAL RATINGS

Power Supply Voltage Continuous Supply Voltage Transient Voltage (Load Dump)	V_{SUP}	27 40	V
WAKE DC and Transient Voltage (Through a 33 k Ω Serial Resistor)	V_{WAKE}	-18 to 40	V
Logic Terminals (RXD, TXD, EN)	V_{LOG}	-0.3 to 5.5	V
LIN DC Voltage Transient (Coupled Through 1.0 nF Capacitor)	V_{BUS}	-18 to 40 -150 to 100	V
INH DC Voltage DC Current	V_{INH} I_{INH}	-0.3 to $V_{SUP} + 0.3$ 40	V mA
ESD Human Body Model (Note 1) All Terminals LIN Terminal with Respect to Ground	V_{ESD1}	± 2000 ± 5000	V
ESD Machine Model (Note 2) All Terminals	V_{ESD2}	± 200	V

THERMAL RATINGS

Operating Temperature Ambient Junction	T_A T_J	-40 to 125 -40 to 150	$^{\circ}\text{C}$
Storage Temperature	T_S	-40 to 150	$^{\circ}\text{C}$
Thermal Resistance Junction to Ambient	$R_{\theta JA}$	150	$^{\circ}\text{C}/\text{W}$
Peak Package Reflow Temperature During Solder Mounting (Note 3)	T_{SOLDER}	240	$^{\circ}\text{C}$
Thermal Shutdown	T_{SHUT}	150 to 200	$^{\circ}\text{C}$
Thermal Shutdown Hysteresis	T_{HYST}	8.0 to 20	$^{\circ}\text{C}$

Notes

- ESD1 testing is performed in accordance with the Human Body Model ($C_{ZAP} = 100 \text{ pF}$, $R_{ZAP} = 1500 \Omega$).
- ESD2 testing is performed in accordance with the Machine Model ($C_{ZAP} = 220 \text{ pF}$, $R_{ZAP} = 0 \Omega$).
- Terminal soldering temperature limit is for 10 seconds maximum duration. Not designed for immersion soldering. Exceeding these limits may cause malfunction or permanent damage to the device.

勝特力材料 886-3-5753170
 勝特力电子(上海) 86-21-54151736
 勝特力电子(深圳) 86-755-83298787
[Http://www.100y.com.tw](http://www.100y.com.tw)

STATIC ELECTRICAL CHARACTERISTICS

Characteristics noted under conditions $7.0\text{ V} \leq V_{\text{SUP}} \leq 18\text{ V}$, $-40^\circ\text{C} \leq T_A \leq 125^\circ\text{C}$, $\text{GND} = 0\text{ V}$ unless otherwise noted. Typical values noted reflect the approximate parameter means at $T_A = 25^\circ\text{C}$ under nominal conditions unless otherwise noted.

Characteristic	Symbol	Min	Typ	Max	Unit
----------------	--------	-----	-----	-----	------

V_{SUP} TERMINAL (DEVICE POWER SUPPLY)

Nominal DC Voltage	V_{SUP}	7.0	13.5	18.0	V
Functional DC Voltage $T_A \geq 25^\circ\text{C}$	V_{SUP}	6.0	–	–	V
Supply Current in Sleep Mode $V_{\text{SUP}} \leq 13.5\text{ V}$, Bus Recessive	I_{S1}	–	8.0	12	μA
$13.5\text{ V} < V_{\text{SUP}} < 18\text{ V}$	I_{S2}	–	–	200	
$V_{\text{SUP}} \leq 13.5\text{ V}$, Bus Dominant or Shorted to GND	I_{S3}	–	300	–	
Supply Current in Normal, Slow or Fast Mode Bus Recessive, Excluding INH Output Current	$I_{\text{S(N-REC)}}$	–	4.0	6.0	mA
Bus Dominant, Total Bus Load $> 500\ \Omega$, Excluding INH Output Current	$I_{\text{S(N-DOM)}}$	–	6.0	8.0	

RXD OUTPUT TERMINAL (LOGIC)

Low-Level Voltage Output $I_{\text{IN}} \leq 1.5\text{ mA}$	V_{OL}	0	–	0.9	V
High-Level Voltage Output $V_{\text{EN}} = 5.0\text{ V}$, $I_{\text{OUT}} \leq 250\ \mu\text{A}$	V_{OH}	4.25	–	5.25	V
$V_{\text{EN}} = 3.3\text{ V}$, $I_{\text{OUT}} \leq 250\ \mu\text{A}$		3.0	–	3.5	

TXD INPUT TERMINAL (LOGIC)

Low-Level Voltage Input	V_{IL}	–	–	1.2	V
High-Level Voltage Input	V_{IH}	2.5	–	–	V
Input Threshold Hysteresis	V_{INHYST}	100	300	800	mV
Pullup Current Source $V_{\text{EN}} = 5.0\text{ V}$, $1.0\text{ V} < V_{\text{TXD}} < 3.5\text{ V}$	I_{S1}	-60	-35	-20	μA

ENABLE INPUT TERMINAL (LOGIC)

Low-Level Voltage Input	V_{IL}	–	–	1.2	V
High-Level Voltage Input	V_{IH}	2.5	–	–	V
Input Threshold Hysteresis	V_{INHYST}	100	300	800	mV
Low-Level Input Current $V_{\text{IN}} = 1.0\text{ V}$	I_{IL}	5.0	20	30	μA
High-Level Input Current $V_{\text{IN}} = 4.0\text{ V}$	I_{IH}	–	20	40	μA

LIN BUS TERMINAL (VOLTAGE EXPRESSED VERSUS V_{SUP} VOLTAGE)

Low-Level Dominant Voltage External Bus Pullup $500\ \Omega$	V_{LINlow}	–	–	1.4	V
High-Level Voltage TXD High, $I_{\text{OUT}} = 1.0\ \mu\text{A}$, Recessive State	V_{LINhigh}	$V_{\text{SUP}} - 1.0$	–	–	V

Freescale Semiconductor, Inc.

STATIC ELECTRICAL CHARACTERISTICS (continued)

Characteristics noted under conditions $7.0\text{ V} \leq V_{\text{SUP}} \leq 18\text{ V}$, $-40^\circ\text{C} \leq T_{\text{A}} \leq 125^\circ\text{C}$, $\text{GND} = 0\text{ V}$ unless otherwise noted. Typical values noted reflect the approximate parameter means at $T_{\text{A}} = 25^\circ\text{C}$ under nominal conditions unless otherwise noted.

Characteristic	Symbol	Min	Typ	Max	Unit
LIN BUS TERMINAL (VOLTAGE EXPRESSED VERSUS V_{SUP} VOLTAGE) (continued)					
Pullup Resistor to V_{SUP} (Normal Mode)	R_{PU}	20	30	47	$\text{k}\Omega$
Pullup Current Source (Sleep Mode)	I_{PU}	–	20	–	μA
Overcurrent Shutdown Threshold	$I_{\text{OV-CUR}}$	50	75	150	mA
Overcurrent Shutdown Delay (Note 4)	$I_{\text{OV-DELAY}}$	–	10	–	μs
Leakage Current to GND Recessive State, $8.0\text{ V} \leq V_{\text{SUP}} \leq 18\text{ V}$, $8.0\text{ V} \leq V_{\text{LIN}} \leq 18\text{ V}$	$I_{\text{BUS-PAS-REC}}$	0	3.0	20	μA
GND Disconnected $V_{\text{GND}} = V_{\text{SUP}}$, V_{LIN} at -18 V	$I_{\text{BUS no GND}}$	-1.0	–	1.0	mA
Leakage Current to GND V_{SUP} Disconnected, V_{LIN} at $+18\text{ V}$	I_{BUS}	–	1.0	10	μA
LIN Receiver V_{IL} TXD High, RXD Low	$V_{\text{LIN-VIL}}$	0	–	$0.4 V_{\text{SUP}}$	V
LIN Receiver V_{IH} TXD High, RXD High	$V_{\text{LIN-VIH}}$	$0.6 V_{\text{SUP}}$	–	V_{SUP}	V
LIN Receiver Threshold Center $(V_{\text{LIN-VIH}} - V_{\text{LIN-VIL}}) / 2$	V_{LINTHRES}	0.475	0.5	0.525	V_{SUP}
LIN Receiver Input Hysteresis $V_{\text{LIN-VIH}} - V_{\text{LIN-VIL}}$	V_{LINHYST}	–	–	0.175	V_{SUP}
LIN Wake-Up Threshold	V_{LINWU}	–	0.5	–	V_{SUP}

INHIBIT OUTPUT TERMINAL

INH Driver ON Resistance (Normal Mode)	INH_{ON}	–	35	70	Ω
Leakage Current (Sleep Mode) $0 < V_{\text{INH}} < V_{\text{SUP}}$	I_{LEAK}	0	–	5.0	μA

WAKE TERMINAL

Typical Wake-Up Threshold ($\text{EN} = 0\text{ V}$, $7.0\text{ V} \leq V_{\text{SUP}} \leq 18\text{ V}$) (Note 5)					V
HIGH-to-LOW Transition	$V_{\text{WUTHRESHL}}$	$0.3 V_{\text{SUP}}$	$0.43 V_{\text{SUP}}$	$0.55 V_{\text{SUP}}$	
LOW-to-HIGH Transition	$V_{\text{WUTHRESLH}}$	$0.4 V_{\text{SUP}}$	$0.55 V_{\text{SUP}}$	$0.65 V_{\text{SUP}}$	
Wake-Up Threshold Hysteresis	V_{WUHYST}	$0.1 V_{\text{SUP}}$	$0.16 V_{\text{SUP}}$	$0.2 V_{\text{SUP}}$	V
WAKE Input Current $\text{V} < 27\text{ V}$	I_{WIN1}	–	1.0	5.0	μA

Notes

- This parameter is guaranteed by design; however, it is not production tested.
- When $V_{\text{SUP}} > 18\text{ V}$, the wake-up thresholds remain identical to the wake-up thresholds at 18 V .

勝特力材料 886-3-5753170
 勝特力电子(上海) 86-21-54151736
 勝特力电子(深圳) 86-755-83298787
[Http://www.100y.com.tw](http://www.100y.com.tw)

Freescale Semiconductor, Inc.

DYNAMIC ELECTRICAL CHARACTERISTICS

Characteristics noted under conditions $7.0\text{ V} \leq V_{\text{SUP}} \leq 18\text{ V}$, $-40^\circ\text{C} \leq T_A \leq 125^\circ\text{C}$, $\text{GND} = 0\text{ V}$ unless otherwise noted. Typical values noted reflect the approximate parameter means at $T_A = 25^\circ\text{C}$ under nominal conditions unless otherwise noted.

Characteristic	Symbol	Min	Typ	Max	Unit
----------------	--------	-----	-----	-----	------

LIN OUTPUT TIMING CHARACTERISTICS FOR NORMAL SLEW RATE

Dominant Propagation Delay TXD to LIN (Note 6) Measurement Threshold (50% TXD to 58.1% V_{SUP})	$t_{\text{DOM}}(\text{MIN})$	–	–	50	μs
Measurement Threshold (50% TXD to 28.4% V_{SUP})	$t_{\text{DOM}}(\text{MAX})$	–	–	50	
Recessive Propagation Delay TXD to LIN (Note 6) Measurement Threshold (50% TXD to 42.2% V_{SUP})	$t_{\text{REC}}(\text{MIN})$	–	–	50	μs
Measurement Threshold (50% TXD to 74.4% V_{SUP})	$t_{\text{REC}}(\text{MAX})$	–	–	50	
Propagation Delay Symmetry $t_{\text{DOM}}(\text{MIN})$ to $t_{\text{REC}}(\text{MAX})$	dt_1	-10.44	–	8.12	μs
$t_{\text{DOM}}(\text{MAX})$ to $t_{\text{REC}}(\text{MIN})$	dt_2	-10.44	–	8.12	

LIN OUTPUT TIMING CHARACTERISTICS FOR SLOW SLEW RATE

Dominant Propagation Delay TXD to LIN (Note 6) Measurement Threshold (50% TXD to 61.6% V_{SUP})	$t_{\text{DOM}}(\text{MIN})$	–	–	100	μs
Measurement Threshold (50% TXD to 25.1% V_{SUP})	$t_{\text{DOM}}(\text{MAX})$	–	–	100	
Recessive Propagation Delay TXD to LIN (Note 6) Measurement Threshold (50% TXD to 38.9% V_{SUP})	$t_{\text{REC}}(\text{MIN})$	–	–	100	μs
Measurement Threshold (50% TXD to 77.8% V_{SUP})	$t_{\text{REC}}(\text{MAX})$	–	–	100	
Propagation Delay Symmetry $t_{\text{DOM}}(\text{MIN})$ to $t_{\text{REC}}(\text{MAX})$	$dt_{1\text{S}}$	-21.88	–	17.44	μs
$t_{\text{DOM}}(\text{MAX})$ to $t_{\text{REC}}(\text{MIN})$	$dt_{2\text{S}}$	-21.88	–	17.44	

LIN OUTPUT DRIVER FAST SLEW RATE

LIN Fast Slew Rate (Programming Mode) Fast Slew Rate	dv/dt fast	–	15	–	$\text{V}/\mu\text{s}$
---	--------------	---	----	---	------------------------

LIN RECEIVER CHARACTERISTICS

Receiver Dominant Propagation Delay (Note 7) LIN LOW to RXD LOW	t_{RL}	–	3.5	6.0	μs
Receiver Recessive Propagation Delay (Note 7) LIN HIGH to RXD HIGH	t_{RH}	–	3.5	6.0	μs
Receiver Propagation Delay Symmetry $t_{\text{RL}} - t_{\text{RH}}$	$t_{\text{R-SYM}}$	-2.0	–	2.0	μs

Notes

- $7.0\text{ V} \leq V_{\text{SUP}} \leq 18\text{ V}$. Bus load R_0 and C_0 : 1.0 nF/1.0 k Ω , 6.8 nF/660 Ω , 10 nF/500 Ω .
- Measured between LIN signal threshold $\text{LIN}-V_{\text{IL}}$ or $\text{LIN}-V_{\text{IH}}$ and 50% of RXD signal.

勝特力材料 886-3-5753170
 勝特力电子(上海) 86-21-54151736
 勝特力电子(深圳) 86-755-83298787
[Http://www.100y.com.tw](http://www.100y.com.tw)

Freescale Semiconductor, Inc.

DYNAMIC ELECTRICAL CHARACTERISTICS (continued)

Characteristics noted under conditions $7.0\text{ V} \leq V_{\text{SUP}} \leq 18\text{ V}$, $-40^\circ\text{C} \leq T_A \leq 125^\circ\text{C}$, $\text{GND} = 0\text{ V}$ unless otherwise noted. Typical values noted reflect the approximate parameter means at $T_A = 25^\circ\text{C}$ under nominal conditions unless otherwise noted.

Characteristic	Symbol	Min	Typ	Max	Unit
----------------	--------	-----	-----	-----	------

SLEEP MODE AND WAKE-UP TIMINGS

LIN Terminal Wake-Up Filter Time (LIN Bus Wake-Up)	t_{WUF}	40	70	120	μs
EN Terminal Wake-Up Time	t_{LWUE}	–	5.0	15	μs
WAKE Terminal Filter Time	t_{WF}	10	–	70	μs
Sleep Mode Delay EN HIGH to LOW	t_{SD}	–	40	–	μs
Delay Between EN and TXD for Mode Selection (Note 8)	$t_{\text{D_MS}}$	5.0	–	–	μs
Delay Between First TXD after Device Mode Selection (Note 8)	$t_{\text{D_COM}}$	50	–	–	μs

Notes

8. This parameter is guaranteed by design; however, it is not production tested.

勝特力材料 886-3-5753170
 勝特力电子(上海) 86-21-54151736
 勝特力电子(深圳) 86-755-83298787
[Http://www.100y.com.tw](http://www.100y.com.tw)

Timing Diagrams

勝特力材料 886-3-5753170
 勝特力电子(上海) 86-21-54151736
 勝特力电子(深圳) 86-755-83298787
[Http://www.100y.com.tw](http://www.100y.com.tw)

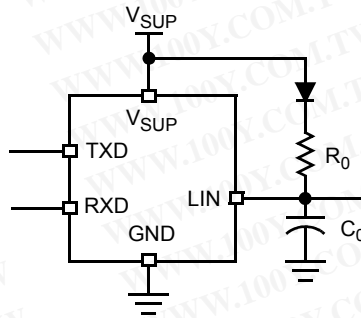

Note R_0 and C_0 : 1.0 k Ω /1.0 nF, 660 Ω /6.8 nF, and 500 Ω /10 nF.

Figure 2. Test Circuit for Timing Measurements

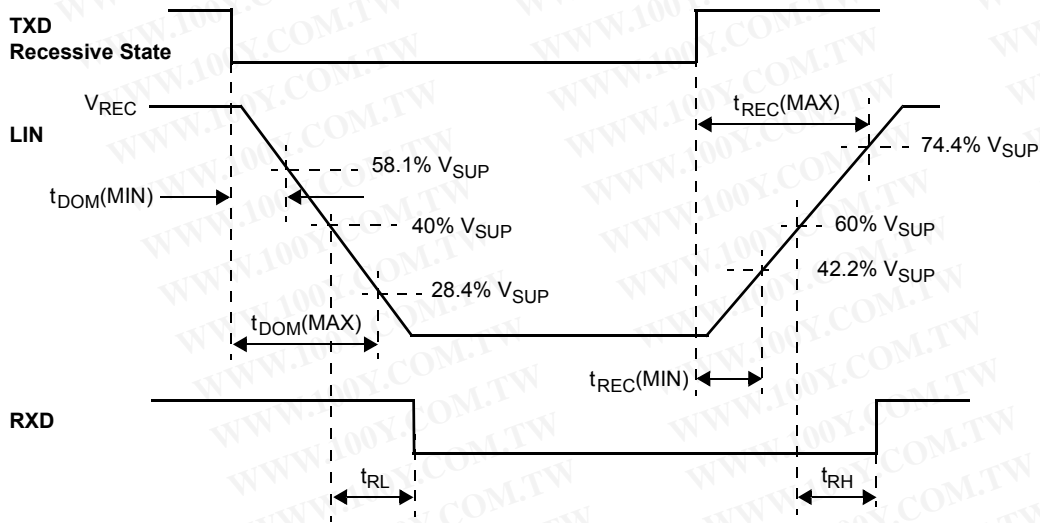

Figure 3. Timing Measurements for Normal Slew Rate

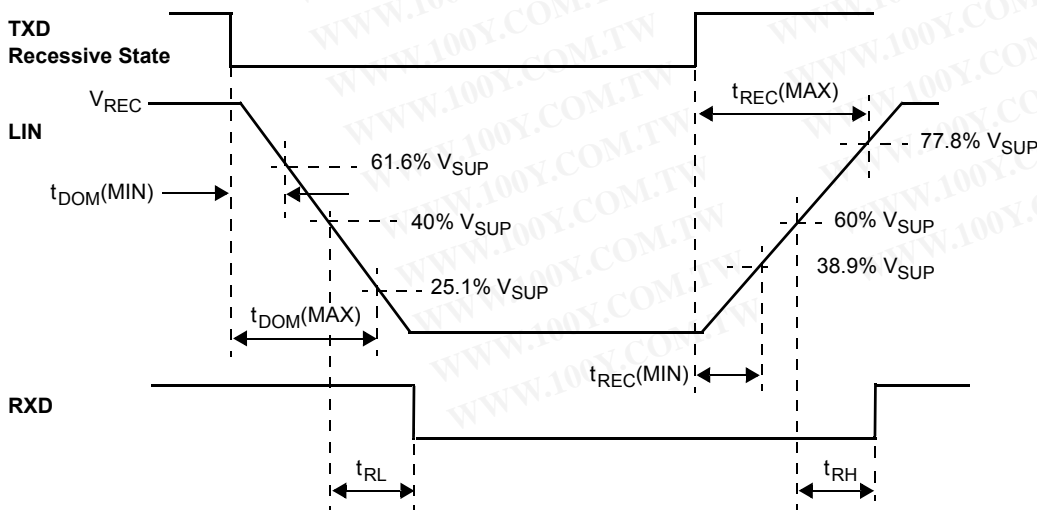

Figure 4. Timing Measurements for Slow Slew Rate

Freescale Semiconductor, Inc.

Functional Diagrams

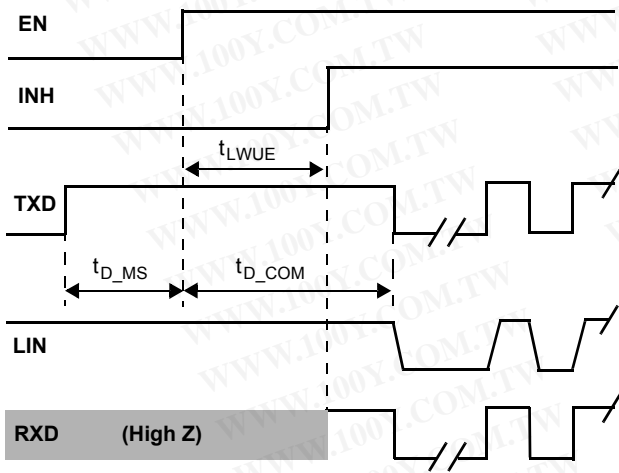

Figure 5. EN Terminal Wake-Up and Normal Baud Rate Selection

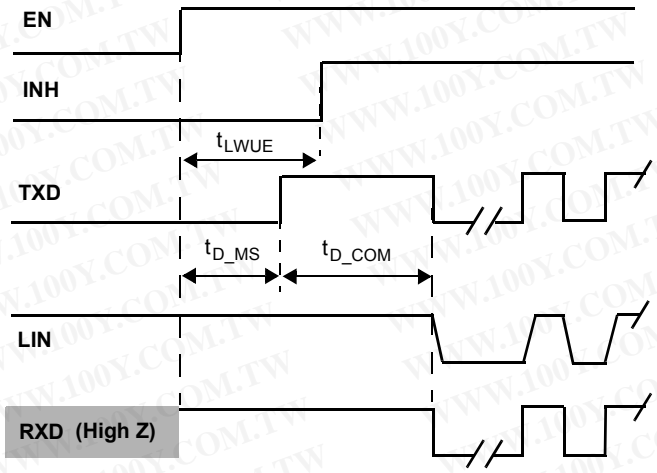

Figure 8. EN Terminal Wake-Up and Slow Baud Rate Selection

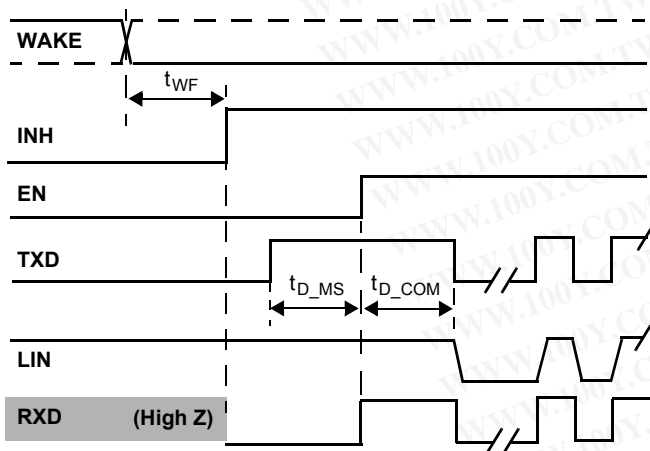

Figure 6. WAKE Terminal Wake-Up and Normal Baud Rate Selection

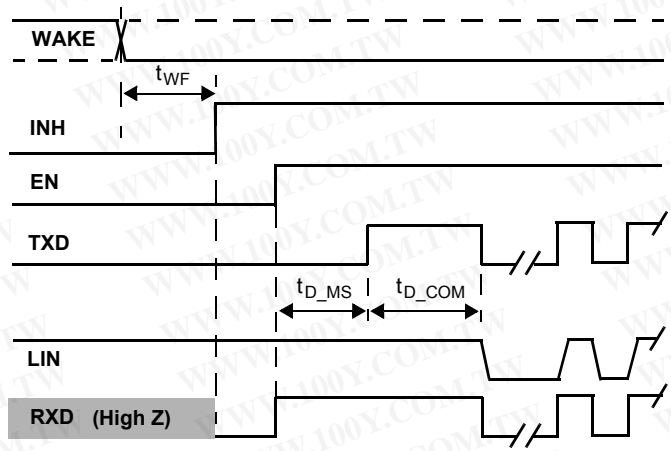

Figure 9. WAKE Terminal Wake-Up and Slow Baud Rate Selection

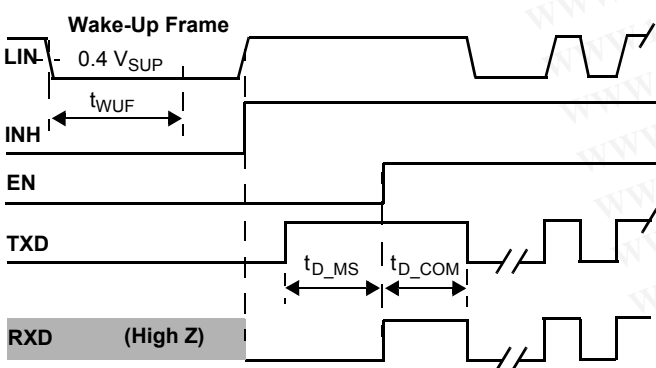

Figure 7. LIN Bus Wake-Up and Normal Baud Rate Selection

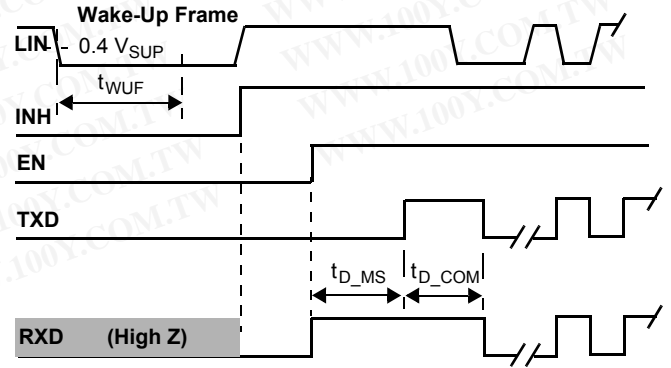

Figure 10. LIN Bus Wake-Up and Slow Baud Rate Selection

Freescale Semiconductor, Inc.

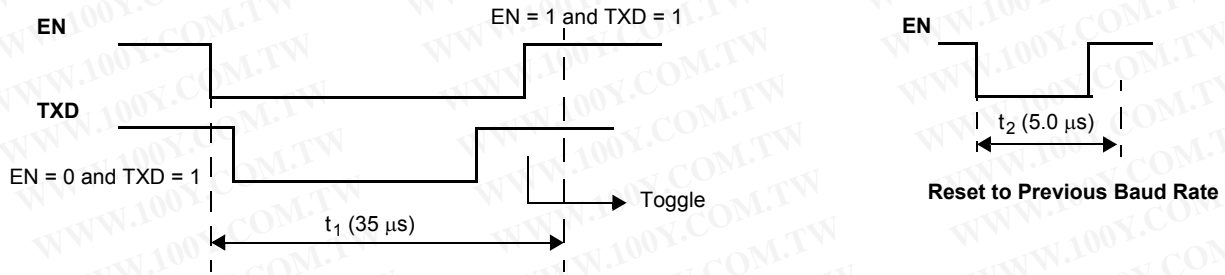

Figure 11. Fast Baud Rate Selection (Toggle Function)

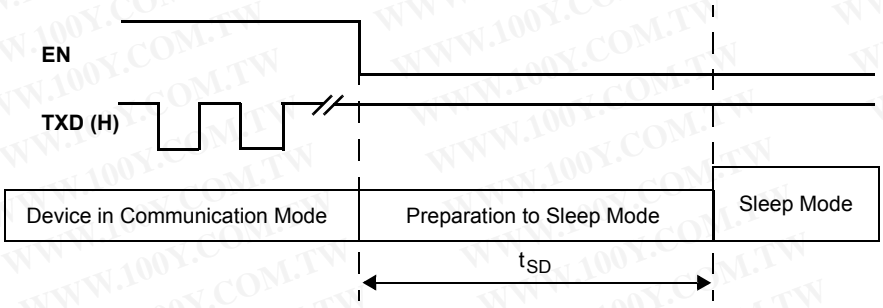
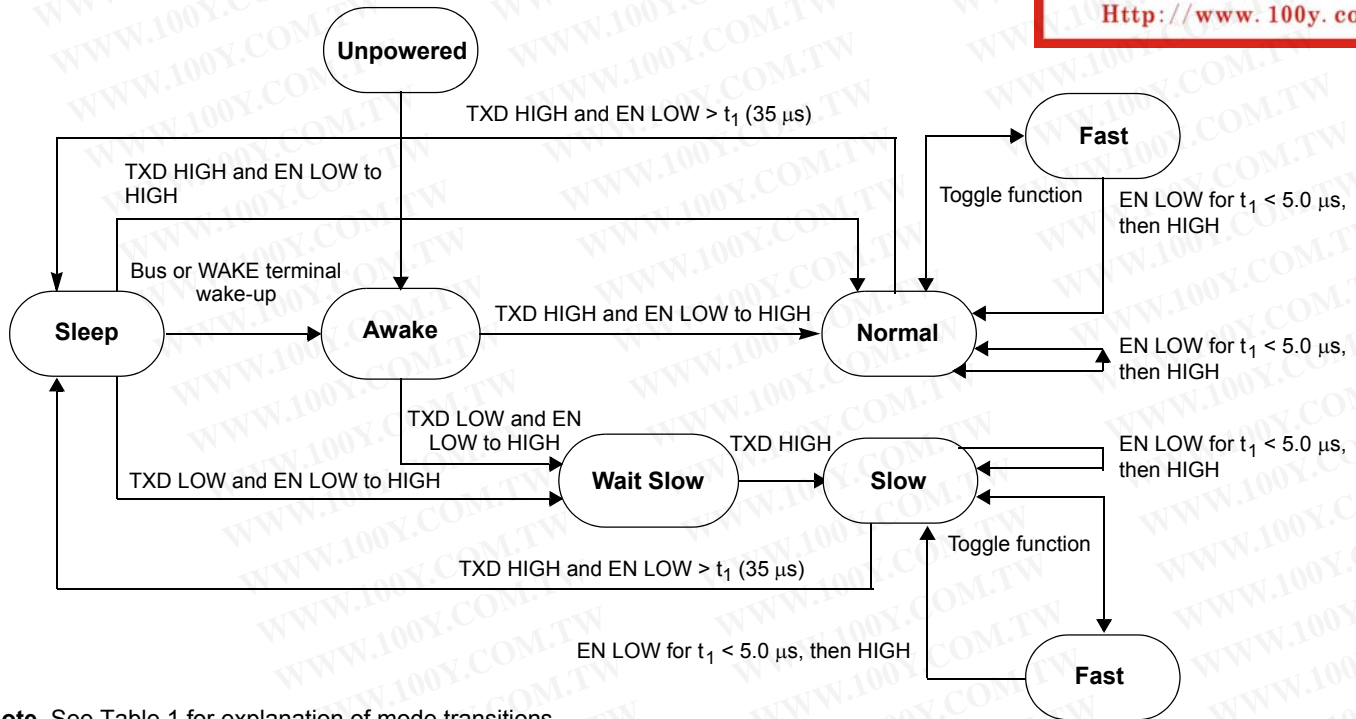

Figure 12. Sleep Mode Enter

勝特力材料 886-3-5753170
 勝特力电子(上海) 86-21-54151736
 勝特力电子(深圳) 86-755-83298787
[Http://www.100y.com.tw](http://www.100y.com.tw)

勝特力材料 886-3-5753170
 勝特力电子(上海) 86-21-54151736
 勝特力电子(深圳) 86-755-83298787
[Http://www.100y.com.tw](http://www.100y.com.tw)



Note See Table 1 for explanation of mode transitions.

Figure 13. Mode Transitions

Table 1. Explanation of Mode Transitions

Mode	Bus	INH	EN	TXD	RXD
Sleep	Recessive state, driver off. 20 μA pullup current source.	OFF	LOW	X	High impedance. HIGH if external pullup to V_{DD} .
Awake	Recessive state, driver off. 30 k Ω pullup active.	ON	LOW	X	Low. If external pullup, HIGH-to-LOW transition reports wake-up.
Normal	Driver active. 30 k Ω pullup active. Slew rate normal (20 kbps).	ON	HIGH	HIGH to enter normal mode. Once in normal mode: LOW to drive bus in dominant, HIGH to drive bus in recessive.	Report bus level: • Low bus dominant • High bus recessive
Wait Slow	Recessive state. Driver off. 30 k Ω pullup active.	ON	HIGH	LOW	HIGH
Slow	Driver active. 30 k Ω pullup active. Slew rate slow (10 kbps).	ON	HIGH	LOW to enter slow mode. Once in slow mode: LOW to drive bus in dominant, HIGH to drive bus in recessive.	Report bus level: • Low bus dominant • High bus recessive
Fast	Driver active. 30 k Ω pullup active. Slew rate slow (> 100 kbps).	ON	HIGH	LOW to drive bus in dominant, HIGH to drive bus in recessive.	Report bus level: • Low bus dominant • High bus recessive

X = Don't care.

SYSTEM/APPLICATION INFORMATION

INTRODUCTION

The 33661 is a Physical Layer component dedicated to automotive LIN sub-bus applications.

The 33661 features include slew rate selection for optimized operation at 10 kbps and 20 kbps, fast baud rate for test and programming modes, excellent radiated emission performance, and safe behavior in case of LIN bus short-to-ground or LIN bus leakage during low power mode.

Digital inputs are 5.0 V and 3.3 V compatible without any external component required.

The INH output may be used to control an external voltage regulator or to drive a LIN bus pullup resistor.

FUNCTIONAL TERMINAL DESCRIPTION

V_{SUP} Supply Terminal

The V_{SUP} supply terminal is the power supply terminal for the 33661.

LIN Bus Terminal

This I/O terminal represents the single-wire bus transmitter and receiver.

TXD Input Terminal

The TXD input terminal is the MCU interface to control the state of the LIN output. When TXD is LOW, LIN output is LOW; when TXD is HIGH, the LIN output transistor is turned OFF. The threshold is 3.3 V and 5.0 V compatible. The baud rate selection (normal or slow mode) is done at device wake-up by the state of the TXD terminal prior to a HIGH level at the EN terminal (see [Figures 5](#) through [10](#), page 10).

RXD Output Terminal

The RXD output terminal is the MCU interface, which reports the state of the LIN bus voltage. LIN HIGH (recessive) is reported by a high voltage on RXD; LIN LOW (dominant) is reported by a low voltage on RXD. The RXD output structure is a CMOS-type push-pull output stage.

The low level is fixed. The high level is dependant on the EN voltage. If EN is set at 3.3 V, RXD V_{OH} is 3.3 V. If EN is set at 5.0 V, RXD V_{OH} is 5.0 V.

In the sleep mode, RXD is high impedance. When a wake-up event is recognized from WAKE terminal or from the LIN bus terminal, RXD is pulled LOW to report the wake-up event. An external pullup resistor may be needed.

EN Input Terminal

The EN input terminal controls the operation mode of the interface. If EN = 1, the interface is in normal mode, with transmission path from TXD to LIN and from LIN to RXD both active. The threshold is 3.3 V and 5.0 V compatible. The high

level at EN defines the V_{OH} at RXD. The sleep mode is entered by setting EN LOW while TXD is HIGH. Sleep mode is active after the t₁ filter time (see [Figure 12](#), page 11).

INH Output Terminal

The INH output terminal may have two main functions. It may be used to control an external switchable voltage regulator having an inhibit input. The high drive capability also allows it to drive the bus external resistor in the master node application. This is illustrated in [Figures 16](#) and [17](#), page 17.

In sleep mode, INH is turned OFF. If a voltage regulator inhibit input is connected to INH, the regulator will be disabled. If the master node pullup resistor is connected to INH, the pullup resistor will be disabled from the LIN bus.

WAKE Input Terminal

The WAKE terminal is a high-voltage input used to wake up the device from the sleep mode. WAKE is usually connected to an external switch in the application. The typical wake thresholds are V_{SUP}/2.

The WAKE terminal has a special design structure and allows wake-up from both HIGH-to-LOW or LOW-to-HIGH transitions. When entering into sleep mode, the LIN monitors the state of the WAKE terminal and stores it as a reference state. The opposite state of this reference state will be the wake-up event used by the device to enter again into normal mode.

An internal filter is implemented (40 μs typical filtering time delay). WAKE terminal input structure exhibits a high impedance, with extremely low input current when voltage at this terminal is below 14 V. When voltage at the WAKE terminal exceeds 14 V, input current starts to sink into the device. A serial resistor should be inserted in order to limit the input current mainly during transient pulses. Recommended resistor value is 33 kΩ.

Important The WAKE terminal should *not* be left open. If the wake-up function is not used, WAKE should be connected to ground to avoid false wake-up.

OPERATIONAL MODES

Introduction

The 33661 has two communication modes, transmitting and receiving modes, and two operational modes, normal and sleep. The normal mode is differentiated by the slew rate—normal, slow, or fast—of the LIN output.

Operational Modes

Normal Mode

In the normal mode, the 33661 has slew rate and timing compatible with the LIN protocol specification and can operate at 20 kbps. This mode is selected after sleep mode by setting the TXD terminal HIGH prior to setting EN from LOW to HIGH. Once normal mode is selected, it is impossible to select the slow mode unless the 33661 is set to sleep mode.

Slow Mode

In the slow mode, the slew rate is around half the normal slew rate, and bus speed operation is limited up to 10 kbps. The radiated emission is significantly reduced compared to the already excellent emission level of the normal mode. Slow mode is entered after sleep mode by setting the TXD terminal LOW prior to setting EN from LOW to HIGH. Once the slow mode is selected, it is impossible to select the normal mode unless the device is set to sleep mode.

Fast Mode

In the fast mode, the slew rate is around 10 times faster than the normal mode. This allows very fast data transmission (>100 kbps)—for instance, for ECU tests and microcontroller program download. The bus pullup resistor might be reduced to ensure a correct RC time constant in line with the high baud rate used. Fast mode is entered via a special sequence (call toggle function) at the TXD and EN terminals described in [Figure 11](#) on page 11. Fast mode can be selected from either normal or slow mode. Once in fast mode, the toggle function will bring the device back in the previously selected mode (normal or slow). A glitch on EN will also reset the device to the previously selected mode (normal or slow) as shown in [Figure 11](#) on page 11.

Sleep Mode

In the sleep mode, the transmission path is disabled and the 33661 is in low power mode. Supply current from V_{SUP} is very low. Wake-up can occur from LIN bus activity from node internal wake-up through the EN terminal and from the WAKE input terminal.

In the sleep mode, the 33661 has an internal 20 μ A pullup source to V_{SUP} . This avoids the high current path from the battery to ground in the event the bus is shorted to ground. (Refer to succeeding paragraphs describing wake-up behavior.)

Device Wake-Up Events

The 33661 can be awakened from sleep mode by three wake-up events: remote wake-up via LIN bus activity, internal node wake-up via the EN terminal, or toggling the WAKE terminal.

Remote Wake from LIN Bus

The LIN bus wake-up is recognized by a recessive-to-dominant transition, followed by a dominant level with a duration greater than 70 μ s, followed by a dominant-to-recessive transition. This is illustrated in [Figures 7](#) and [10](#) on page 10. Once the wake-up is detected, the 33661 enters the “awake” mode, with INH HIGH and RXD pulled LOW.

Wake-Up from Internal Node Activity

The 33661 can wake up by internal node activity through a LOW-to-HIGH transition of the EN terminal. When EN is switched from LOW to HIGH, the device is awakened and enters either the “normal” or the “wait slow” mode depending on the level of TXD input. The MCU must set the TXD terminal LOW or HIGH prior to waking up the device through the EN terminal.

Wake-Up from WAKE Terminal

If the WAKE input terminal is toggled, the 33661 enters the “awake” mode, with INH HIGH and RXD pulled LOW.

Device Power-Up

At power-up (V_{SUP} rises from zero), the 33661 automatically switches in the “awake” mode. It switches the INH terminal to HIGH state and RXD to LOW state. The MCU of the application will then confirm normal or slow mode by setting the TXD and EN terminals appropriately.

勝特力材料 886-3-5753170
勝特力电子(上海) 86-21-54151736
勝特力电子(深圳) 86-755-83298787
[Http://www.100y.com.tw](http://www.100y.com.tw)

ELECTROMAGNETIC COMPATIBILITY INFORMATION

Radiated Emission in Normal and Slow Modes

The 33661 has been tested for radiated emission performances. Figures 14 and 15 show the results in the frequency range 100 kHz to 2.0 MHz. Test conditions are in accordance with CISPR25 recommendations, bus length of 1.5 meter, device loaded with 10 nF and 500 Ω bus impedance.

Figure 14 displays the results when the device is set in the normal mode, optimized for baud rate up to 20 kbps. Figure 15 displays the results when the device is set in the slow mode, optimized for baud rate up to 10 kbps. The level of emissions is significantly reduced compared to the already excellent level of the normal mode.

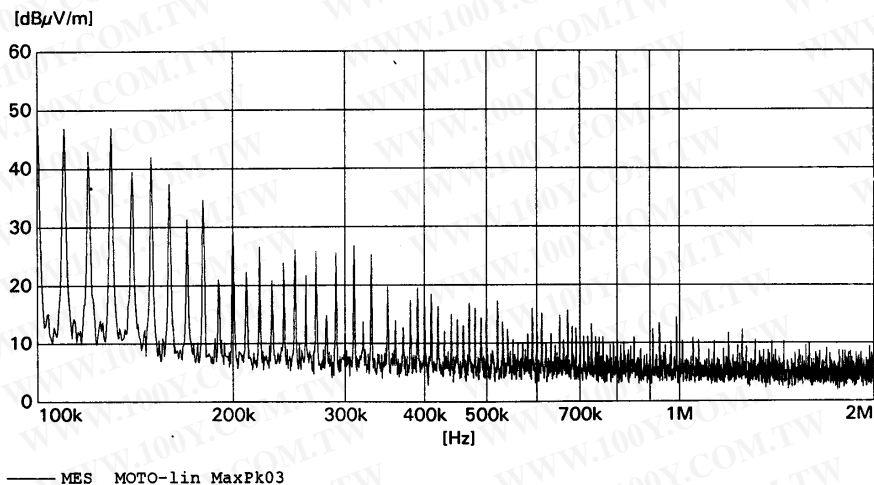

Figure 14. Radiated Emission in Normal Mode

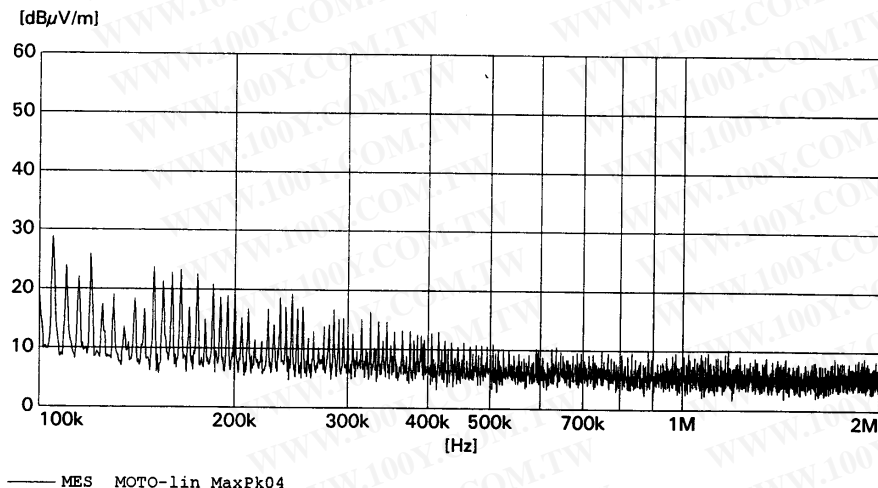

Figure 15. Radiated Emission in Slow Mode

勝特力材料 886-3-5753170
勝特力电子(上海) 86-21-54151736
勝特力电子(深圳) 86-755-83298787
[Http://www.100y.com.tw](http://www.100y.com.tw)

Freescale Semiconductor, Inc.

APPLICATIONS

Motorola Device Compatibility: 33661 and 33399

The two Motorola devices are terminal-to-terminal compatible. [Table 2](#) summarizes the differences between the two devices.

Table 2. Compatibility Comparison

Parameter	33661	33399
Terminal Out and Package	8-terminal SOICN.	8-terminal SOICN.
Baud Rate Operation	2 baud rate operations: from 1.0 to 10 kbps and from 1.0 to 20 kbps.	1 baud rate operation from 1.0 to 20 kbps.
INH Output	Capable of: <ul style="list-style-type: none"> Controlling an external switchable voltage regulator. Driving a bus master termination resistor. 	Capable of controlling an external switchable voltage regulator.
WAKE Terminal	Identical to 33399.	Identical to 33661.
TXD, RXD, EN	5.0 V and 3.3 V compatible.	5.0 V compatible only.
LIN Bus Termination	In normal, slow, and fast mode, 30 k Ω pullup. In sleep mode and bus short-to-ground, 20 μ A pullup.	30 k Ω pullup in normal and sleep modes.
Sleep Current	Typical 8.0 μ A.	Typical 20 μ A, maximum 50 μ A.
Mode	Normal, slow, fast, and sleep modes.	Normal and sleep modes.
Normal Mode	Selected by TXD HIGH, then EN HIGH at device wake-up. Operation up to 20 kbps.	Selected by TXD high and EN high at device wake-up. Operation up to 20 kbps.
Slow Mode	Selected by TXD LOW, then EN HIGH at device wake-up. Operation up to 10 kbps.	N/A
Fast Mode	Selected by sequence at TXD and EN. Operation at baud rate >100 kbps.	N/A
Sleep Mode and Bus Wake-Up	Recessive-to-dominant transition, followed by a dominant state of more than 70 μ s, followed by a dominant-to-recessive transition.	Dominant level, 50 μ s duration.
Slew Rate	Three slew rates: Normal (20 kbps), Slow (10 kbps), and Fast (> 100 kbps). Normal and slow mode selected by EN and TXD terminal sequence at device wake-up. The sequence to enter normal mode is the same for both the 33399 and 33661.	One slew rate: 20 kbps.
Wake-Up from Internal Node Activity (LOW to HIGH transition of EN)	If TXD is set HIGH and then EN is switched HIGH, the 33661 wakes up and the Normal Mode is selected. In this setup sequence, there is a direct compatibility between 33399 and 33661.	TXD must be set HIGH prior to setting EN HIGH in order to avoid having the device send a dominant level on the bus at wake-up.
Radiated Emission	The level of radiated emissions measured in identical configurations is lower for the 33661 compared to the 33399 in the normal mode, allowing operation up to 20 kbps. If the 33661 device is set to the slow mode, allowing operation up to 10 kbps, the radiated emission level is significantly reduced.	The level of radiated emissions measured in identical configurations is higher for the 33399 compared to the 33661 in the normal mode.

勝特力材料 886-3-5753170
 勝特力电子(上海) 86-21-54151736
 勝特力电子(深圳) 86-755-83298787
[Http://www.100y.com.tw](http://www.100y.com.tw)

Typical Applications

Figures 16 and 17 show typical applications of the 33661.

勝特力材料 886-3-5753170
 勝特力电子(上海) 86-21-54151736
 勝特力电子(深圳) 86-755-83298787
[Http://www.100y.com.tw](http://www.100y.com.tw)

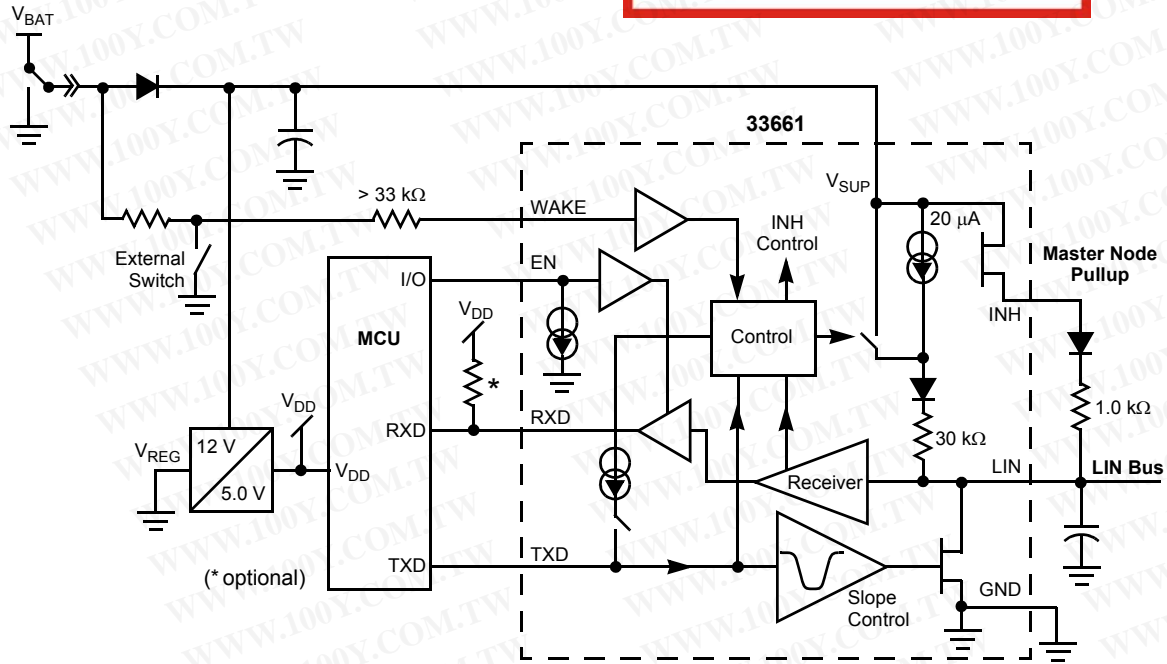

Figure 16. Master Node Typical Application

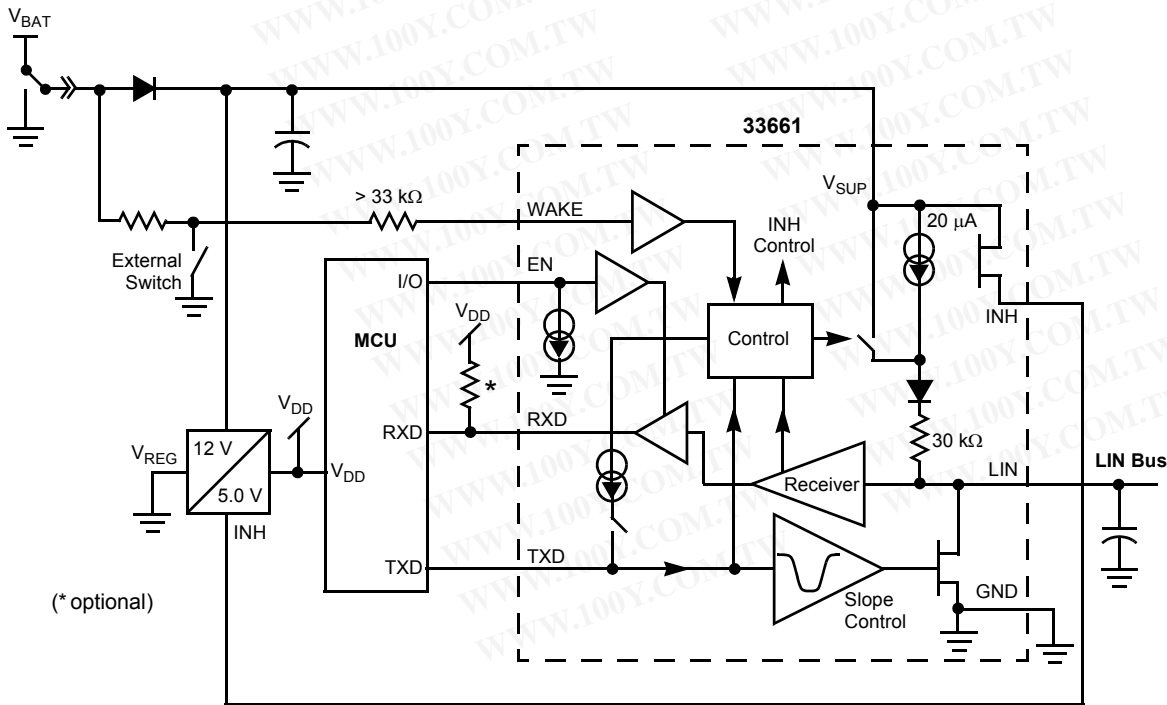
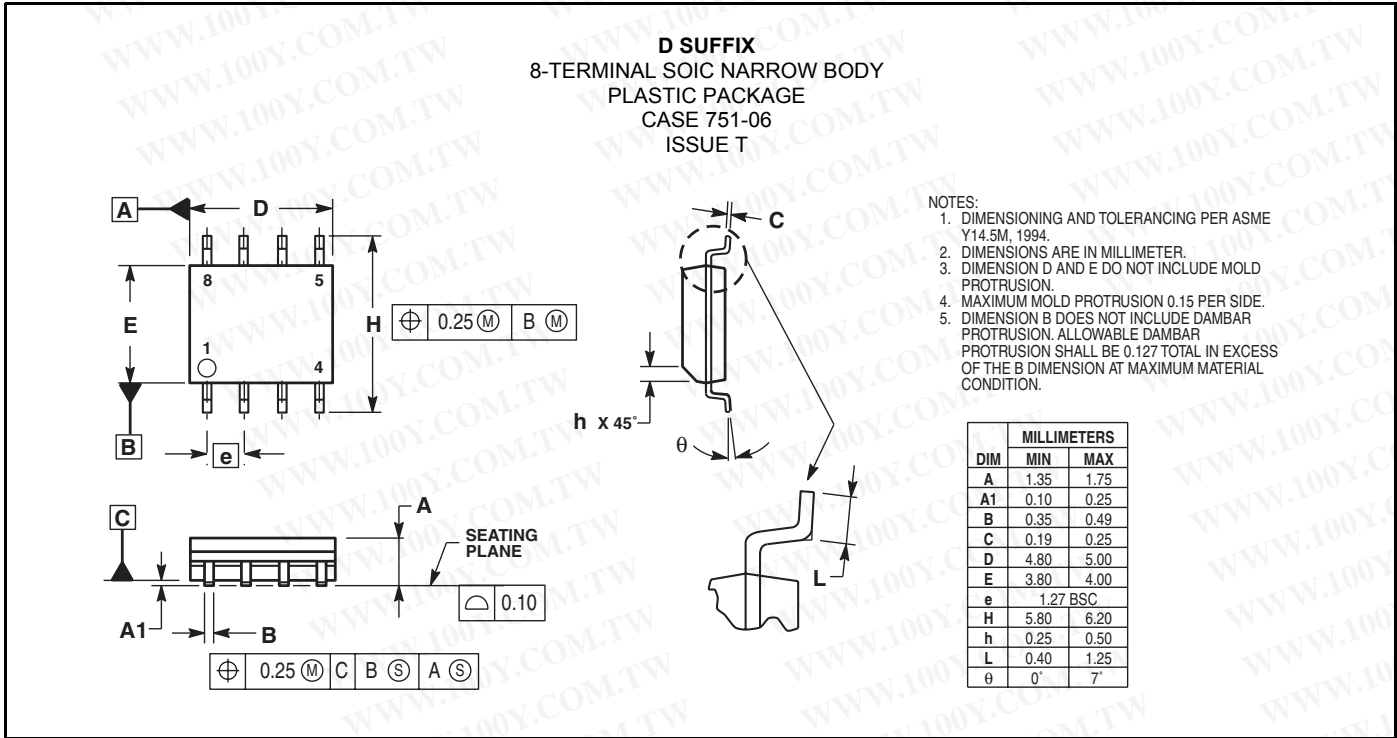

Figure 17. Slave Node Typical Application

PACKAGE DIMENSIONS



勝特力材料 886-3-5753170
 勝特力电子(上海) 86-21-54151736
 勝特力电子(深圳) 86-755-83298787
[Http://www.100y.com.tw](http://www.100y.com.tw)

NOTES

勝特力材料 886-3-5753170
勝特力电子(上海) 86-21-54151736
勝特力电子(深圳) 86-755-83298787
[Http://www.100y.com.tw](http://www.100y.com.tw)

Freescale Semiconductor, Inc.

Freescale Semiconductor, Inc.

勝特力材料 886-3-5753170
勝特力电子(上海) 86-21-54151736
勝特力电子(深圳) 86-755-83298787
[Http://www.100y.com.tw](http://www.100y.com.tw)

Information in this document is provided solely to enable system and software implementers to use Motorola products. There are no express or implied copyright licenses granted hereunder to design or fabricate any integrated circuits or integrated circuits based on the information in this document.

Motorola reserves the right to make changes without further notice to any products herein. Motorola makes no warranty, representation or guarantee regarding the suitability of its products for any particular purpose, nor does Motorola assume any liability arising out of the application or use of any product or circuit, and specifically disclaims any and all liability, including without limitation consequential or incidental damages. "Typical" parameters which may be provided in Motorola data sheets and/or specifications can and do vary in different applications and actual performance may vary over time. All operating parameters, including "Typicals" must be validated for each customer application by customer's technical experts. Motorola does not convey any license under its patent rights nor the rights of others. Motorola products are not designed, intended, or authorized for use as components in systems intended for surgical implant into the body, or other applications intended to support or sustain life, or for any other application in which the failure of the Motorola product could create a situation where personal injury or death may occur. Should Buyer purchase or use Motorola products for any such unintended or unauthorized application, Buyer shall indemnify and hold Motorola and its officers, employees, subsidiaries, affiliates, and distributors harmless against all claims, costs, damages, and expenses, and reasonable attorney fees arising out of, directly or indirectly, any claim of personal injury or death associated with such unintended or unauthorized use, even if such claim alleges that Motorola was negligent regarding the design or manufacture of the part.

MOTOROLA and the Stylized M Logo are registered in the US Patent and Trademark Office. All other product or service names are the property of their respective owners.

© Motorola, Inc. 2004

HOW TO REACH US:

USA/EUROPE/LOCATIONS NOT LISTED:

Motorola Literature Distribution
P.O. Box 5405, Denver, Colorado 80217
1-800-521-6274 or 480-768-2130

JAPAN: Motorola Japan Ltd.; SPS, Technical Information Center
3-20-1 Minami-Azabu, Minato-ku, Tokyo 106-8573, Japan
81-3-3440-3569

ASIA/PACIFIC: Motorola Semiconductors H.K. Ltd.; Silicon Harbour Centre
2 Dai King Street, Tai Po Industrial Estate, Tai Po, N.T., Hong Kong
852-26668334

HOME PAGE: <http://motorola.com/semiconductors>



MOTOROLA

**For More Information On This Product,
Go to: www.freescale.com**

MC33661