

勝特力材料 886-3-5753170
 勝特力电子(上海) 86-21-54151736
 勝特力电子(深圳) 86-755-83298787
[Http://www.100y.com.tw](http://www.100y.com.tw)

NOTES:
 1.MAT'L : NYLON 66 + BRASS
 2.FINISH : TIN PLATED
 3.ORDERING INFORMATION
 MIFSM-2 XX T1W041
 PIN NO.

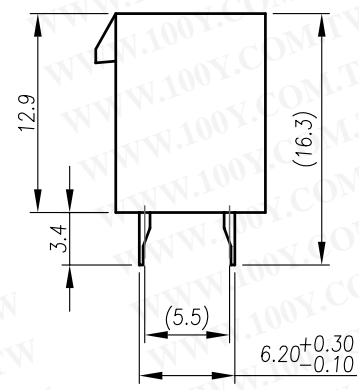

PART NO.	DIM.A	DIM.B
MIFSM-202T1W041	5.6	
MIFSM-204T1W041	9.8	4.20
MIFSM-206T1W041	13.9	8.40
MIFSM-208T1W041	18.1	12.60
MIFSM-210T1W041	22.4	16.80
MIFSM-212T1W041	26.7	21.00
MIFSM-214T1W041	30.8	25.20
MIFSM-216T1W041	35.0	29.40
MIFSM-218T1W041	39.2	33.60
MIFSM-220T1W041	43.7	37.80
MIFSM-222T1W041	47.6	42.00
MIFSM-224T1W041	51.8	46.20

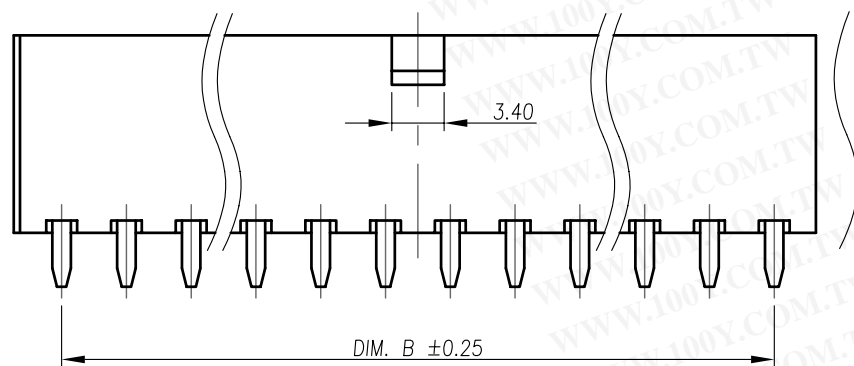
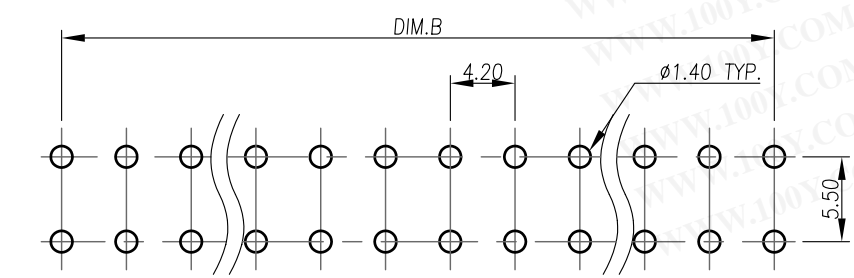

DIMENSION IN mm [Inch]		PROD. SPEC.	TITLE MINI FIT CONN. ST. TYPE 4.2mm PITCH		CUSTOMER DRAWING
TOLERANCE UNLESS OTHERWISE SPECIFIED		PKG. SPEC.			
.X±0.35	X*±	APPROVE	FILE NO.	DWG NO. MIFSM-2XXT1W041	
.XX±0.10	.X*±	CHECK	SIZE A4	PROJ.	SHEET 1 / 1
.XXX±	.XX*±	DRAW	SCALE 2:1	REV A	