

# CLOCK OSCILLATORS

## "H" series

Logic: TTL / HCMOS  
Wave Form: Square wave



MERCURY  
Since 1973

Besides low cost general purpose crystal clock oscillators Mercury also offers high quality and field-proven application-specific oscillators for applications such as

- ◆ CPU, graphics, multimedia A/V clocks
- ◆ MPEG / DVD / HDTV clocks
- ◆ Laser engine pixel / set-top clocks
- ◆ Spread spectrum low EMI clocks
- ◆ OC-3, OC-12, OC-48 and OC-192 clocks
- ◆ Fast Ethernet and Gigabit Ethernet clocks
- ◆ NTSC / PAL encoder/decoder clocks
- ◆ PLL / synthesizer clocks
- ◆ Fibre channel and ADSL clocks
- ◆ SONET / SDH / ATM clocks

Mercury has the right oscillators to meet your specifications and your applications.

### Product Summary

勝特力材料 886-3-5753170  
勝特力电子(上海) 86-21-54151736  
勝特力电子(深圳) 86-755-83298787  
[Http://www.100y.com.tw](http://www.100y.com.tw)

Package Code	Frequency Range	Assembly Technique	Package Size (mm) [inches], seat height
<b>Thru-Hole Types</b>			
H14	20 KHz ~ 160 MHz	4 pin DIL full size	12.8 x 20.2 x 5.88 [0.504 x 0.795 x 0.231]
H8	20 KHz ~ 160 MHz	4 pin DIL half size	12.8 x 12.8 x 5.88 [0.504 x 0.504 x 0.231]
<b>Surface Mount Types – Gull Wing</b>			
H24	20 KHz ~ 160 MHz	Gull wing version of H14	12.8 x 20.2 x 7.60 [0.504 x 0.795 x 0.300]
H18	20 KHz ~ 160 MHz	Gull wing version of H8	12.8 x 12.8 x 7.60 [0.504 x 0.504 x 0.300]
<b>Surface Mount Types – Leadless</b>			
H41	1.25 MHz ~160 MHz	4 pad Leadless	9.6 x 11.4 x 1.85 [0.378 x 0.449 x 0.073]
H42	20 kHz ~160 MHz	4 pad Leadless	9.6 x 11.4 x 2.5 [0.378 x 0.449 x 0.098]
H44	20 kHz ~160 MHz	4 pad Leadless	9.6 x 11.4 x 4.7 [0.378 x 0.449 x 0.185]
H575	20 MHz ~160 MHz	4 pad Leadless	5.0 x 7.5 x 2.8 [0.197 x 0.295 x 0.110]

For Hz or kHz range clock oscillators with uA (micro amps) current consumption, for example 32.768 kHz with 14 uA current, please refer to the LPO series.

# CLOCK OSCILLATORS

## "H" series

Logic: TTL / HCMOS  
Wave Form: Square wave



MERCURY  
Since 1973

### "H" Series General Specifications

$T_A = +25^\circ\text{C}$ ,  $V_{DD}$  at specified voltage,  $C_L = 15\text{ pF}$

Input Voltage ( $V_{DD}$ )		$V_{DD} = +3.3\text{ V D.C. } \pm 5\%$	$V_{DD} = +5.0\text{ V D.C. } \pm 5\%$
Frequency Range (package dependent)		20 kHz ~ 125 MHz	20 kHz ~ 160 MHz
Output Logic		TTL / HCMOS	TTL / HCMOS
Output Voltage HIGH "1"	TTL	2.4 V min.	2.4 V min.
	CMOS	2.97 min.	$V_{CC} - 0.5\text{ min.}$
Output Voltage LOW "0"	TTL	0.4 V max.	0.4 V max.
	CMOS	0.33 max.	0.5 V max.
Operating Temperature Range		Commercial (Temperature code is "C"): $0^\circ\text{C}$ to $+70^\circ\text{C}$ Industrial (Temperature code is "I"): $-40^\circ\text{C}$ to $+85^\circ\text{C}$	
Frequency Stability <sup>(1)</sup>	Commercial ( $0^\circ\text{C}$ to $+70^\circ\text{C}$ ) Temperature code is "C"	$\pm 25\text{ ppm}$ over $0^\circ\text{C}$ to $+70^\circ\text{C}$ (Stability code is "A") $\pm 50\text{ ppm}$ over $0^\circ\text{C}$ to $+70^\circ\text{C}$ (Stability code is "B") $\pm 100\text{ ppm}$ over $0^\circ\text{C}$ to $+70^\circ\text{C}$ (Stability code is "C") If non-standard please enter the desired stability after the "C". For example "C20" represents $\pm 20\text{ ppm}$ over 0 to $+70^\circ\text{C}$	
	Industrial ( $-40^\circ\text{C}$ to $+85^\circ\text{C}$ ) Temperature code is "I"	$\pm 25\text{ ppm}$ over $-40^\circ\text{C}$ to $+85^\circ\text{C}$ (Stability code is "D") $\pm 50\text{ ppm}$ over $-40^\circ\text{C}$ to $+85^\circ\text{C}$ (Stability code is "E") $\pm 100\text{ ppm}$ over $-40^\circ\text{C}$ to $+85^\circ\text{C}$ (Stability code is "F") If non-standard please enter the desired stability after the "I". For example "I20" represents $\pm 20\text{ ppm}$ over $-40$ to $+85^\circ\text{C}$	
Output Load	TTL	2 ~ 10 TTL gates	
	CMOS	15 or 50 pF	
Rise Time ( $T_r$ ) and Fall Time ( $T_f$ )	TTL	10 n Sec. max; 3 n Sec. typical. Measured between 0.4V to 2.4V (RL=390 $\Omega$ ; CL=15 pF)	
	CMOS	10 n Sec. max; 3 n Sec. typical. Measured between 10% to 90% $V_{DD}$ (CL=15 pF)	
Duty Cycle	TTL	40% min. 60 % max. (measured at +1.4 V)	
	CMOS	40% min. 60 % max. (measured at 50% $V_{DD}$ )	
Start-up Time ( $T_s$ )		10 m Sec. max. 5 m Sec. typical	
Current Consumption		15 ~ 45 mA (frequency dependent)	
Option on pin 1		Output is high impedance when "0" ( $\leq 0.8\text{V}$ ) is applied to pin 1. Disable time is 150 n sec. max. Please add "T" after the stability code for this option.	
Storage Temperature		$-50^\circ\text{C}$ to $+100^\circ\text{C}$	
Aging		$\pm 5\text{ ppm}$ per year max.	

<sup>(1)</sup>Inclusive of  $25^\circ\text{C}$  tolerance, operating temperature range,  $\pm 10\%$  input voltage variation, load change, aging, shock and vibration.

勝特力材料 886-3-5753170  
 勝特力电子(上海) 86-21-54151736  
 勝特力电子(深圳) 86-755-83298787  
[Http://www.100y.com.tw](http://www.100y.com.tw)



**Part Number Format and Examples:**

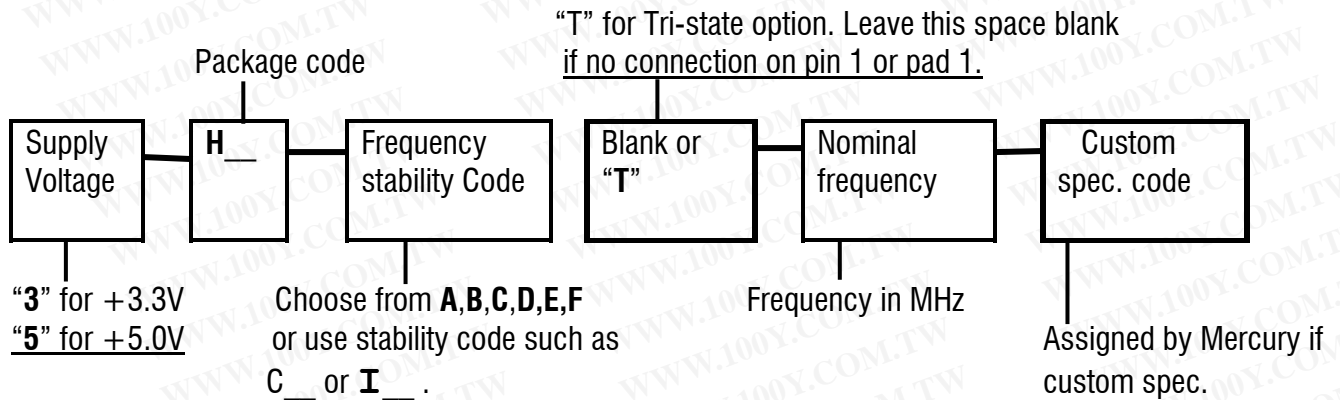

3H8-BT-72.000 represents +3.3V input voltage, half size 4 pin DIP package, ±50 ppm over 0 to +70°C frequency stability, Tri-state function on pin 1, 72.000 MHz

5H44-A-1.544-2315 represents +5.0V input voltage, H44 package, ±25 ppm over 0 to +70°C frequency stability, 1.544 MHz. Non-standard and custom spec. No. is 2315.

**OUTPUT WAVEFORM:**

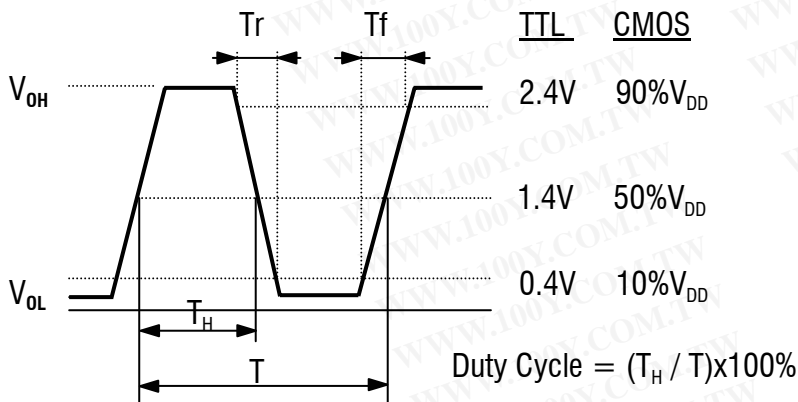

勝特力材料 886-3-5753170  
 勝特力电子(上海) 86-21-54151736  
 勝特力电子(深圳) 86-755-83298787  
[Http://www.100y.com.tw](http://www.100y.com.tw)

Package: H14

Unit: mm [inches]

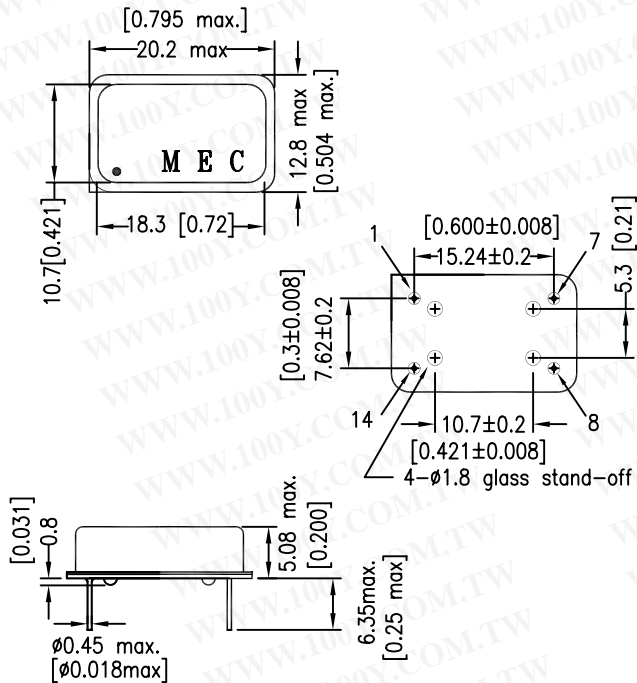

**Pin Connections**

Squared corner is pin No. 1

- Pin 1: No Connection or Output Disabled when Low
- Pin 7: Ground
- Pin 8: Output
- Pin 14: Supply Voltage

Package: H8

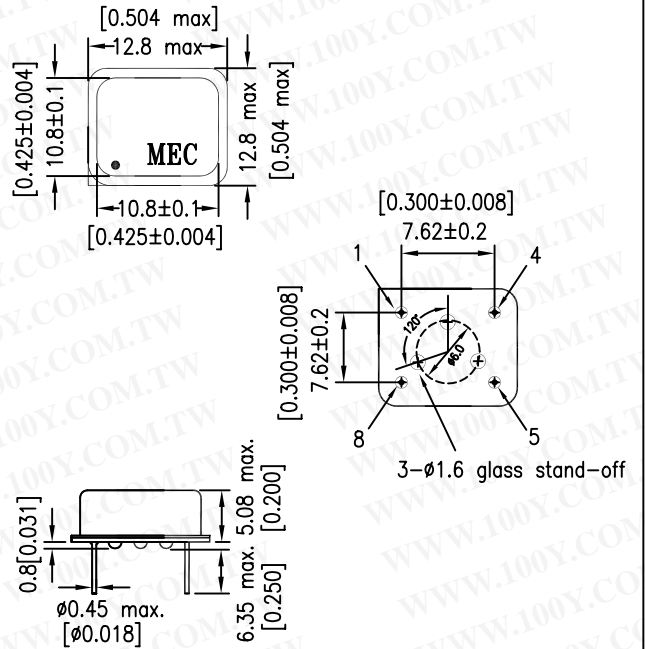

**Pin Connections**

Squared corner is pin No. 1

- Pin 1: No Connection or Output Disabled when Low
- Pin 4: Ground
- Pin 5: Output
- Pin 8: Supply Voltage

C L O C K  
T T L / C M O S

Package: H24

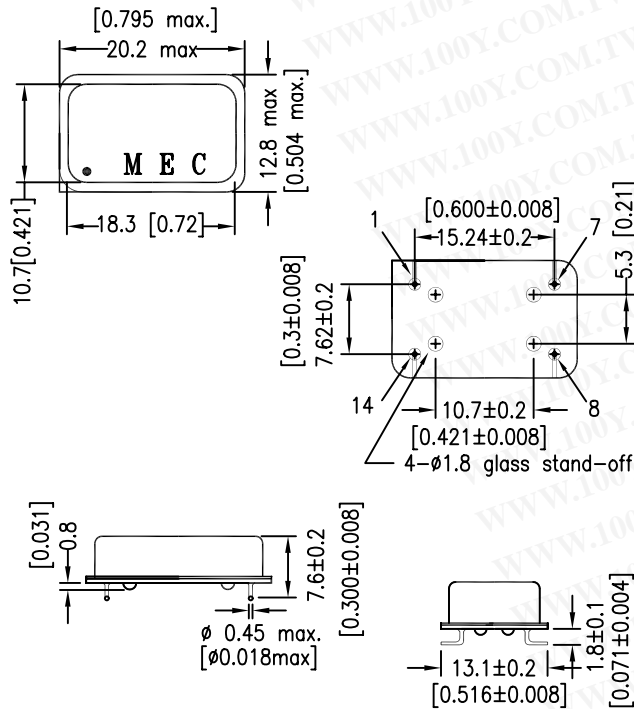

**Pin Connections**

Squared Corner is pin No. 1

- Pin 1: No Connection or Output Disabled when Low
- Pin 7: Ground
- Pin 8: Output
- Pin 14: Supply Voltage

Package: H18

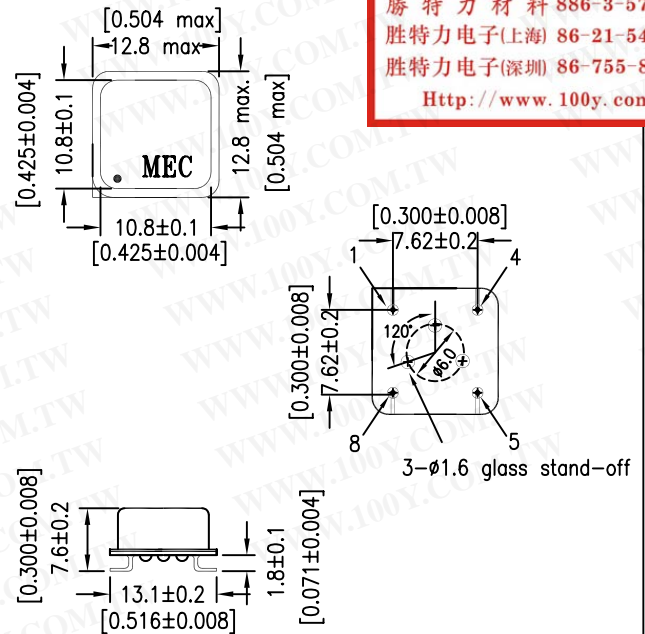

**Pin Connections**

Squared corner is pin No. 1

- Pin 1: No Connection or Output Disabled when Low
- Pin 4: Ground
- Pin 5: Output
- Pin 8: Supply Voltage

勝特力材料 886-3-5753170  
 勝特力电子(上海) 86-21-54151736  
 勝特力电子(深圳) 86-755-83298787  
[Http://www.100y.com.tw](http://www.100y.com.tw)

**Package: H41**

"41" represents 4 pads and 1.85 mm overall height

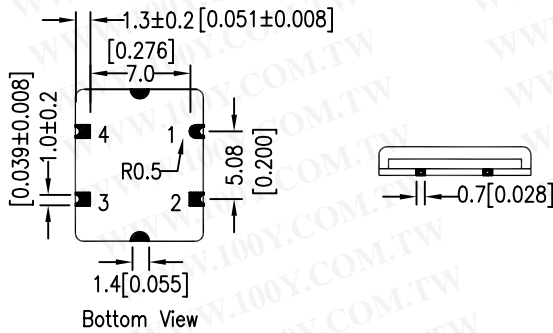
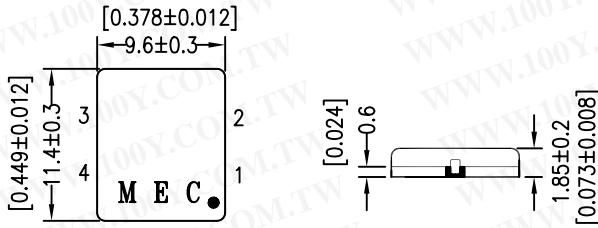

**Pad Connections:** Rounded pad is pad 1  
 Pad 1: No Connection or option  
 Pad 2: Ground  
 Pad 3: Output  
 Pad 4: Supply Voltage

**Package: H42**

Unit: mm [inches]

"42" represents 4 pads and 2.5 mm overall height

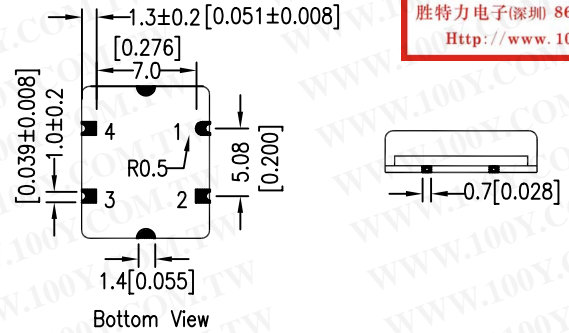
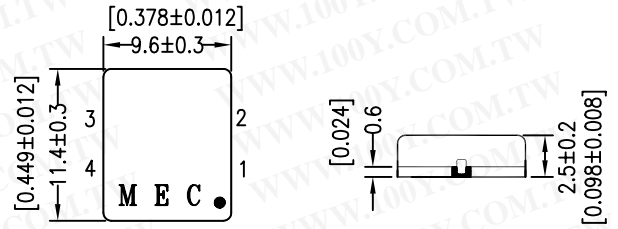

**Pad Connections:** Rounded pad is pad 1  
 Pad 1: No Connection or option  
 Pad 2: Ground  
 Pad 3: Output  
 Pad 4: Supply Voltage

勝特力材料 886-3-5753170  
 勝特力电子(上海) 86-21-54151736  
 勝特力电子(深圳) 86-755-83298787  
[Http://www.100y.com.tw](http://www.100y.com.tw)

C L O C K  
 TTL/CMOS

**Package: H44**

"44" represents 4 pads and 4.7 mm overall height

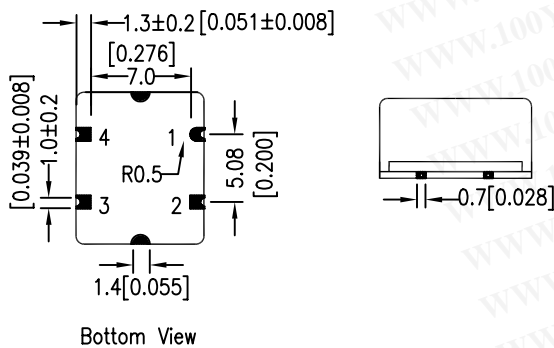
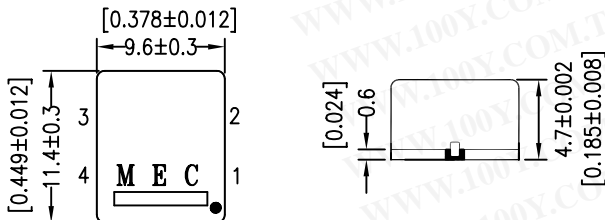

**Pad Connections:** Rounded pad is pad 1  
 Pad 1: No connection or option  
 Pad 2: Ground  
 Pad 3: Output  
 Pad 4: Supply Voltage

**Package: H575**

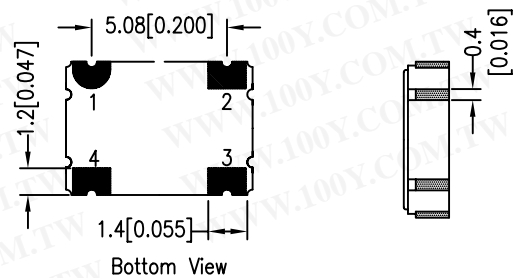
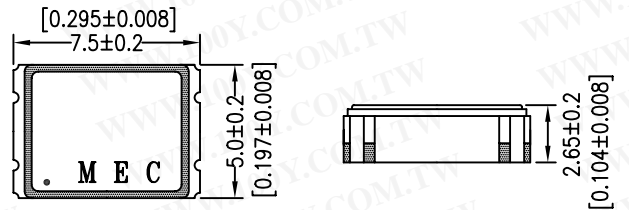

**Pad Connections:** Rounded pad is pad 1  
 Pad 1: Tri-state or No connection  
 Pad 2: Ground  
 Pad 3: Output  
 Pad 4: Supply voltage