

CLOCK OSCILLATORS

"H" series

Logic: TTL / HCMOS
Wave Form: Square wave



MERCURY
Since 1973

Besides low cost general purpose crystal clock oscillators Mercury also offers high quality and field-proven application-specific oscillators for applications such as

- ◆ CPU, graphics, multimedia A/V clocks
- ◆ MPEG / DVD / HDTV clocks
- ◆ Laser engine pixel / set-top clocks
- ◆ Spread spectrum low EMI clocks
- ◆ OC-3, OC-12, OC-48 and OC-192 clocks
- ◆ Fast Ethernet and Gigabit Ethernet clocks
- ◆ NTSC / PAL encoder/decoder clocks
- ◆ PLL / synthesizer clocks
- ◆ Fibre channel and ADSL clocks
- ◆ SONET / SDH / ATM clocks

Mercury has the right oscillators to meet your specifications and your applications.

Product Summary

勝特力材料 886-3-5753170
勝特力电子(上海) 86-21-54151736
勝特力电子(深圳) 86-755-83298787
[Http://www.100y.com.tw](http://www.100y.com.tw)

Package Code	Frequency Range	Assembly Technique	Package Size (mm) [inches], seat height
Thru-Hole Types			
H14	20 KHz ~ 160 MHz	4 pin DIL full size	12.8 x 20.2 x 5.88 [0.504 x 0.795 x 0.231]
H8	20 KHz ~ 160 MHz	4 pin DIL half size	12.8 x 12.8 x 5.88 [0.504 x 0.504 x 0.231]
Surface Mount Types – Gull Wing			
H24	20 KHz ~ 160 MHz	Gull wing version of H14	12.8 x 20.2 x 7.60 [0.504 x 0.795 x 0.300]
H18	20 KHz ~ 160 MHz	Gull wing version of H8	12.8 x 12.8 x 7.60 [0.504 x 0.504 x 0.300]
Surface Mount Types – Leadless			
H41	1.25 MHz ~ 160 MHz	4 pad Leadless	9.6 x 11.4 x 1.85 [0.378 x 0.449 x 0.073]
H42	20 kHz ~ 160 MHz	4 pad Leadless	9.6 x 11.4 x 2.5 [0.378 x 0.449 x 0.098]
H44	20 kHz ~ 160 MHz	4 pad Leadless	9.6 x 11.4 x 4.7 [0.378 x 0.449 x 0.185]
H575	20 MHz ~ 160 MHz	4 pad Leadless	5.0 x 7.5 x 2.8 [0.197 x 0.295 x 0.110]

For Hz or kHz range clock oscillators with uA (micro amps) current consumption, for example 32.768 kHz with 14 uA current, please refer to the LPO series.

CLOCK OSCILLATORS

"H" series

Logic: TTL / HCMOS
Wave Form: Square wave



MERCURY
Since 1973

"H" Series General Specifications

$T_A = +25^\circ\text{C}$, V_{DD} at specified voltage, $C_L = 15\text{ pF}$

Input Voltage (V_{DD})		$V_{DD} = +3.3\text{ V D.C. } \pm 5\%$	$V_{DD} = +5.0\text{ V D.C. } \pm 5\%$
Frequency Range (package dependent)		20 kHz ~ 125 MHz	20 kHz ~ 160 MHz
Output Logic		TTL / HCMOS	TTL / HCMOS
Output Voltage HIGH "1"	TTL	2.4 V min.	2.4 V min.
	CMOS	2.97 min.	$V_{CC} - 0.5\text{ min.}$
Output Voltage LOW "0"	TTL	0.4 V max.	0.4 V max.
	CMOS	0.33 max.	0.5 V max.
Operating Temperature Range		Commercial (Temperature code is "C"): 0°C to $+70^\circ\text{C}$ Industrial (Temperature code is "I"): -40°C to $+85^\circ\text{C}$	
Frequency Stability ⁽¹⁾	Commercial (0°C to $+70^\circ\text{C}$) Temperature code is "C"	$\pm 25\text{ ppm}$ over 0°C to $+70^\circ\text{C}$ (Stability code is "A") $\pm 50\text{ ppm}$ over 0°C to $+70^\circ\text{C}$ (Stability code is "B") $\pm 100\text{ ppm}$ over 0°C to $+70^\circ\text{C}$ (Stability code is "C") If non-standard please enter the desired stability after the "C". For example "C20" represents $\pm 20\text{ ppm}$ over 0 to $+70^\circ\text{C}$	
	Industrial (-40°C to $+85^\circ\text{C}$) Temperature code is "I"	$\pm 25\text{ ppm}$ over -40°C to $+85^\circ\text{C}$ (Stability code is "D") $\pm 50\text{ ppm}$ over -40°C to $+85^\circ\text{C}$ (Stability code is "E") $\pm 100\text{ ppm}$ over -40°C to $+85^\circ\text{C}$ (Stability code is "F") If non-standard please enter the desired stability after the "I". For example "I20" represents $\pm 20\text{ ppm}$ over -40 to $+85^\circ\text{C}$	
Output Load	TTL	2 ~ 10 TTL gates	
	CMOS	15 or 50 pF	
Rise Time (T_r) and Fall Time (T_f)	TTL	10 n Sec. max; 3 n Sec. typical. Measured between 0.4V to 2.4V (RL=390 Ω ; CL=15 pF)	
	CMOS	10 n Sec. max; 3 n Sec. typical. Measured between 10% to 90% V_{DD} (CL=15 pF)	
Duty Cycle	TTL	40% min. 60 % max. (measured at +1.4 V)	
	CMOS	40% min. 60 % max. (measured at 50% V_{DD})	
Start-up Time (T_s)		10 m Sec. max. 5 m Sec. typical	
Current Consumption		15 ~ 45 mA (frequency dependent)	
Option on pin 1		Output is high impedance when "0" ($\leq 0.8\text{V}$) is applied to pin 1. Disable time is 150 n sec. max. Please add "T" after the stability code for this option.	
Storage Temperature		-50°C to $+100^\circ\text{C}$	
Aging		$\pm 5\text{ ppm}$ per year max.	

⁽¹⁾Inclusive of 25°C tolerance, operating temperature range, $\pm 10\%$ input voltage variation, load change, aging, shock and vibration.

勝特力材料 886-3-5753170
 勝特力电子(上海) 86-21-54151736
 勝特力电子(深圳) 86-755-83298787
[Http://www.100y.com.tw](http://www.100y.com.tw)



Part Number Format and Examples:

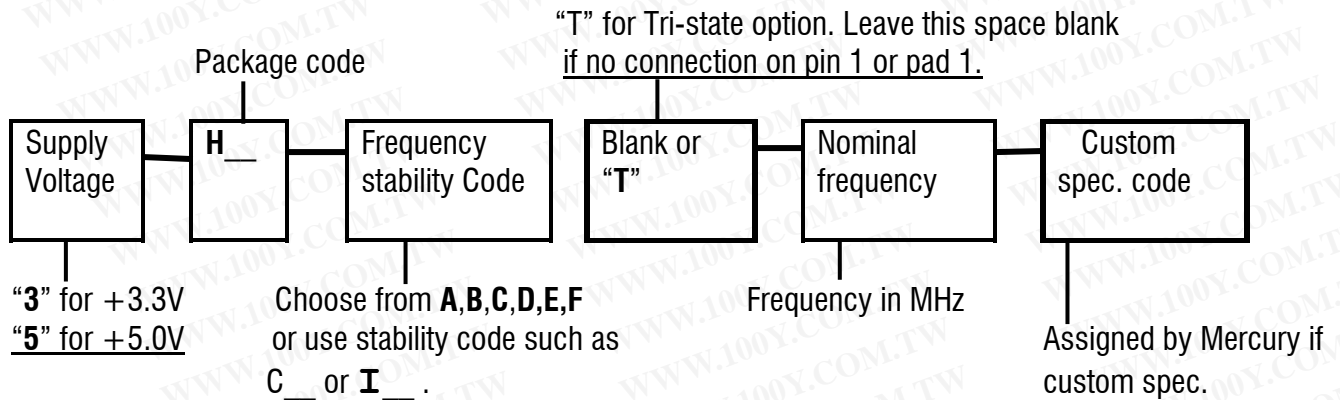

3H8-BT-72.000 represents +3.3V input voltage, half size 4 pin DIP package, ±50 ppm over 0 to +70°C frequency stability, Tri-state function on pin 1, 72.000 MHz

5H44-A-1.544-2315 represents +5.0V input voltage, H44 package, ±25 ppm over 0 to +70°C frequency stability, 1.544 MHz. Non-standard and custom spec. No. is 2315.

OUTPUT WAVEFORM:

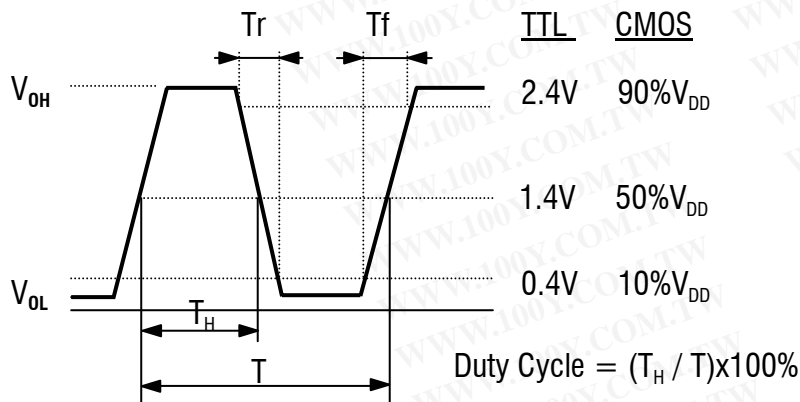

勝特力材料 886-3-5753170
 勝特力电子(上海) 86-21-54151736
 勝特力电子(深圳) 86-755-83298787
[Http://www.100y.com.tw](http://www.100y.com.tw)

Package: H14

Unit: mm [inches]

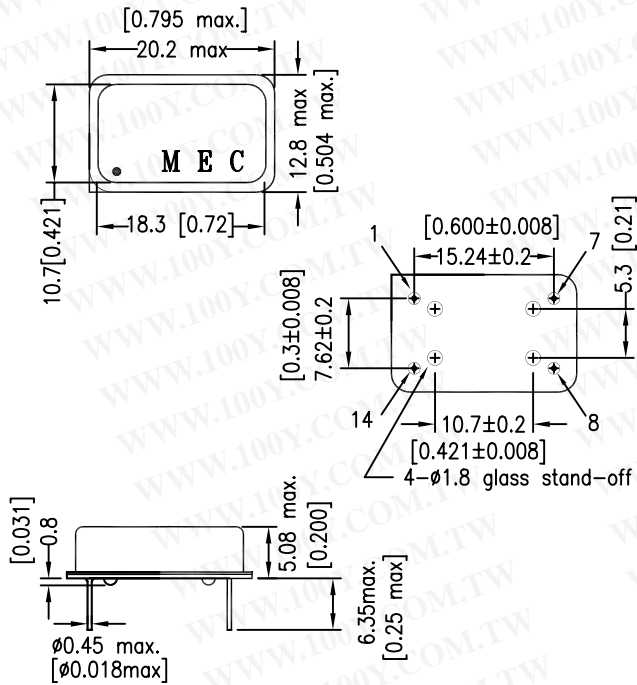

Pin Connections

Squared corner is pin No. 1

- Pin 1: No Connection or Output Disabled when Low
- Pin 7: Ground
- Pin 8: Output
- Pin 14: Supply Voltage

Package: H8

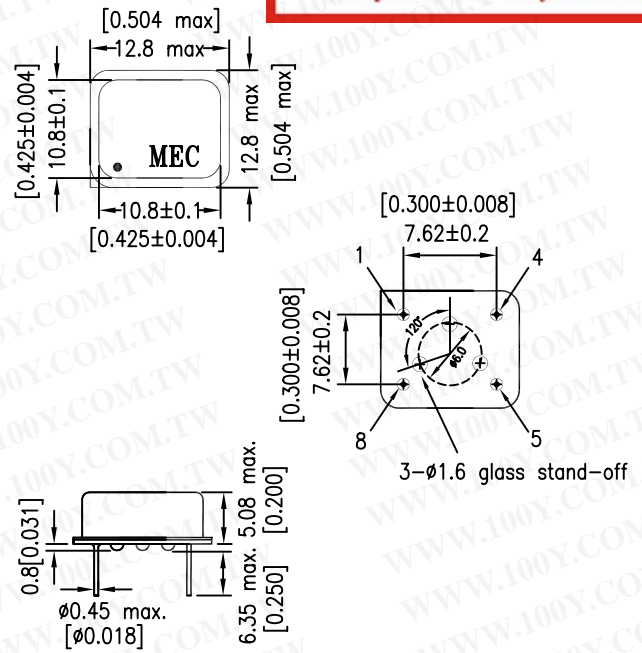

Pin Connections

Squared corner is pin No. 1

- Pin 1: No Connection or Output Disabled when Low
- Pin 4: Ground
- Pin 5: Output
- Pin 8: Supply Voltage

C L O C K
T T L / C M O S

Package: H24

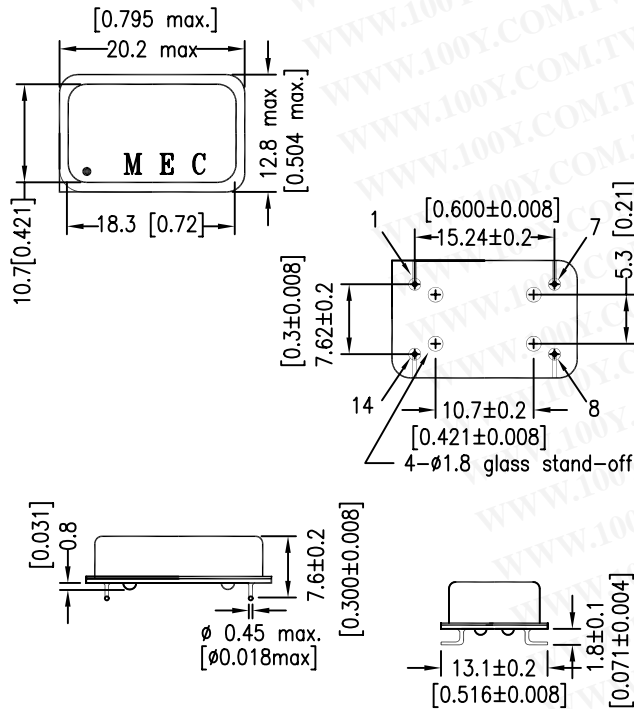

Pin Connections

Squared Corner is pin No. 1

- Pin 1: No Connection or Output Disabled when Low
- Pin 7: Ground
- Pin 8: Output
- Pin 14: Supply Voltage

Package: H18

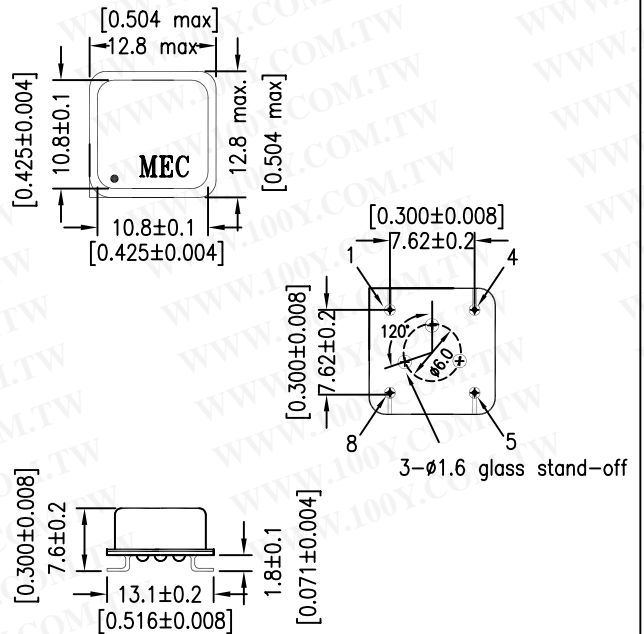

Pin Connections

Squared corner is pin No. 1

- Pin 1: No Connection or Output Disabled when Low
- Pin 4: Ground
- Pin 5: Output
- Pin 8: Supply Voltage

Package: H41

"41" represents 4 pads and 1.85 mm overall height

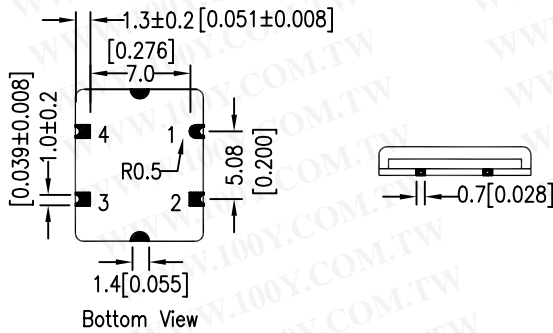
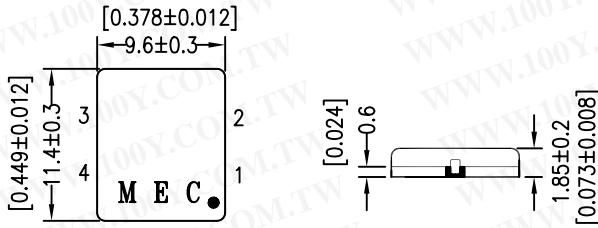

Pad Connections: Rounded pad is pad 1
 Pad 1: No Connection or option
 Pad 2: Ground
 Pad 3: Output
 Pad 4: Supply Voltage

Package: H42

Unit: mm [inches]

"42" represents 4 pads and 2.5 mm overall height

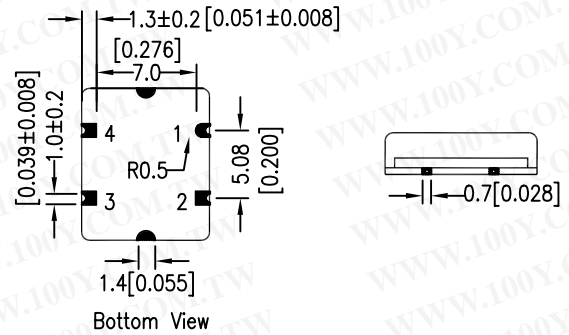
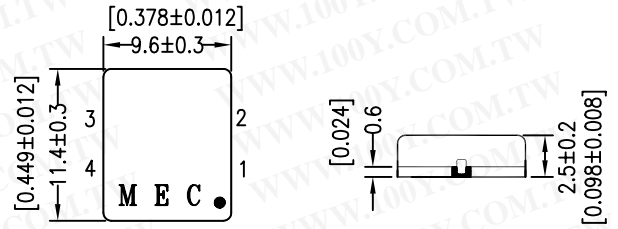

Pad Connections: Rounded pad is pad 1
 Pad 1: No Connection or option
 Pad 2: Ground
 Pad 3: Output
 Pad 4: Supply Voltage

C L O C K
TTL/CMOS

Package: H44

"44" represents 4 pads and 4.7 mm overall height

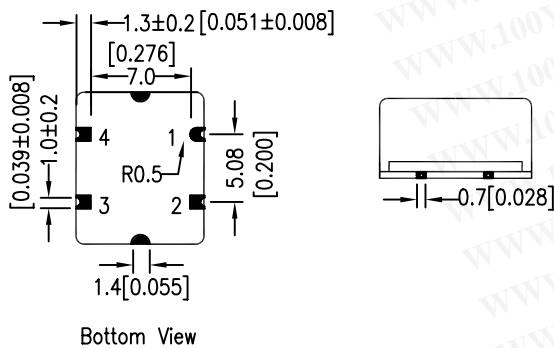
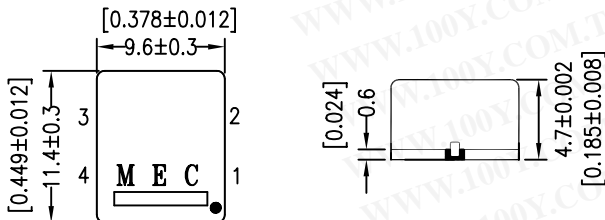

Pad Connections: Rounded pad is pad 1
 Pad 1: No connection or option
 Pad 2: Ground
 Pad 3: Output
 Pad 4: Supply Voltage

Package: H575

勝特力材料 886-3-5753170
 勝特力电子(上海) 86-21-54151736
 勝特力电子(深圳) 86-755-83298787
[Http://www.100y.com.tw](http://www.100y.com.tw)

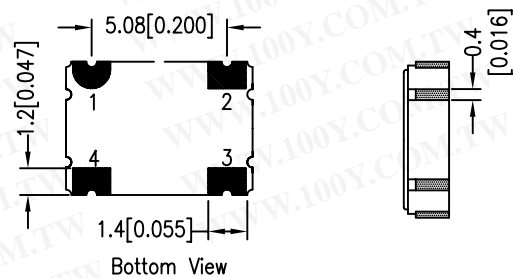
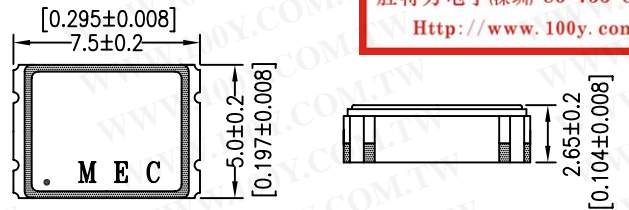

Pad Connections: Rounded pad is pad 1
 Pad 1: Tri-state or No connection
 Pad 2: Ground
 Pad 3: Output
 Pad 4: Supply voltage