

# MC34152, MC33152, NCV33152

## High Speed Dual MOSFET Drivers

The MC34152/MC33152 are dual noninverting high speed drivers specifically designed for applications that require low current digital signals to drive large capacitive loads with high slew rates. These devices feature low input current making them CMOS/LSTTL logic compatible, input hysteresis for fast output switching that is independent of input transition time, and two high current totem pole outputs ideally suited for driving power MOSFETs. Also included is an undervoltage lockout with hysteresis to prevent system erratic operation at low supply voltages.

Typical applications include switching power supplies, dc-to-dc converters, capacitor charge pump voltage doublers/inverters, and motor controllers.

This device is available in dual-in-line and surface mount packages.

- Two Independent Channels with 1.5 A Totem Pole Outputs
- Output Rise and Fall Times of 15 ns with 1000 pF Load
- CMOS/LSTTL Compatible Inputs with Hysteresis
- Undervoltage Lockout with Hysteresis
- Low Standby Current
- Efficient High Frequency Operation
- Enhanced System Performance with Common Switching Regulator Control ICs

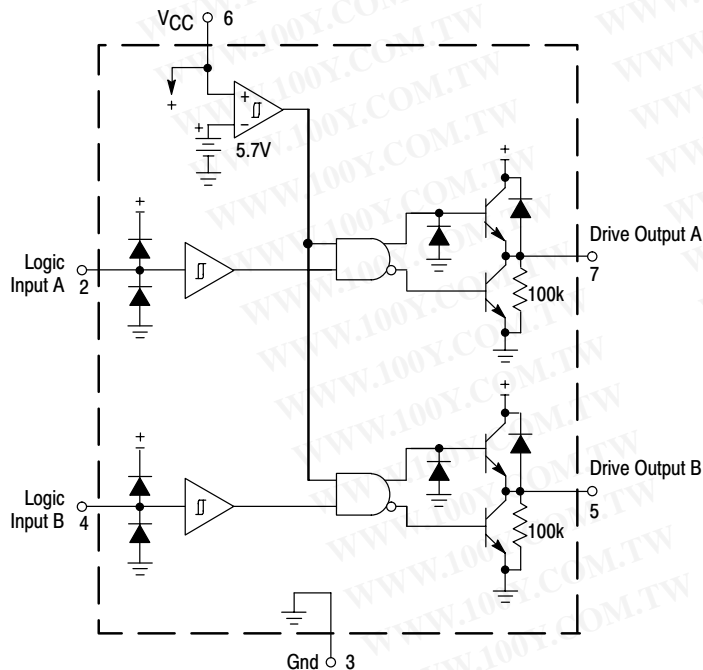
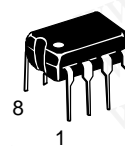

Figure 1. Representative Diagram



ON Semiconductor™

### MARKING DIAGRAMS



PDIP-8  
P SUFFIX  
CASE 626

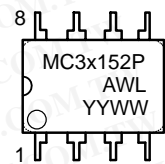

SO-8  
D SUFFIX  
CASE 751

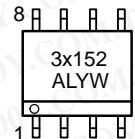

x = 3 or 4  
 A = Assembly Location  
 WL, L = Wafer Lot  
 YY, Y = Year  
 WW, W = Work Week

### PIN CONNECTIONS

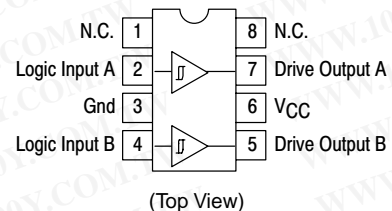

### ORDERING INFORMATION

Device	Package	Shipping
MC34152D	SO-8	98 Units/Rail
MC34152DR2	SO-8	2500 Tape & Reel
MC34152P	PDIP-8	50 Units/Rail
MC33152D	SO-8	98 Units/Rail
MC33152DR2	SO-8	2500 Tape & Reel
MC33152P	PDIP-8	50 Units/Rail
MC33152VDR2	SO-8	2500 Tape & Reel
NCV33152DR2	SO-8	2500 Tape & Reel

## MC34152, MC33152, NCV33152

### MAXIMUM RATINGS

Rating	Symbol	Value	Unit
Power Supply Voltage	$V_{CC}$	20	V
Logic Inputs (Note 1)	$V_{in}$	-0.3 to $V_{CC}$	V
Drive Outputs (Note 2) Totem Pole Sink or Source Current Diode Clamp Current (Drive Output to $V_{CC}$ )	$I_O$ $I_{O(clamp)}$	1.5 1.0	A
Power Dissipation and Thermal Characteristics D Suffix, Plastic Package Case 751 Maximum Power Dissipation @ $T_A = 50^\circ\text{C}$ Thermal Resistance, Junction-to-Air P Suffix, Plastic Package, Case 626 Maximum Power Dissipation @ $T_A = 50^\circ\text{C}$ Thermal Resistance, Junction-to-Air	$P_D$ $R_{\theta JA}$ $P_D$ $R_{\theta JA}$	0.56 180 1.0 100	W $^\circ\text{C/W}$ W $^\circ\text{C/W}$
Operating Junction Temperature	$T_J$	+150	$^\circ\text{C}$
Operating Ambient Temperature MC34152 MC33152 MC33152V, NCV33152	$T_A$	0 to +70 -40 to +85 -40 to +125	$^\circ\text{C}$
Storage Temperature Range	$T_{stg}$	-65 to +150	$^\circ\text{C}$
Electrostatic Discharge Sensitivity (ESD) Human Body Model (HBM) Machine Model (MM)	ESD	2000 200	V

- For optimum switching speed, the maximum input voltage should be limited to 10 V or  $V_{CC}$ , whichever is less.
- Maximum package power dissipation limits must be observed.

**勝特力材料 886-3-5753170**  
**勝特力电子(上海) 86-21-54151736**  
**勝特力电子(深圳) 86-755-83298787**  
[Http://www.100y.com.tw](http://www.100y.com.tw)

## MC34152, MC33152, NCV33152

**ELECTRICAL CHARACTERISTICS** ( $V_{CC} = 12\text{ V}$ , for typical values  $T_A = 25^\circ\text{C}$ , for min/max values  $T_A$  is the operating ambient temperature range that applies [Note 3], unless otherwise noted.)

Characteristics	Symbol	Min	Typ	Max	Unit
<b>LOGIC INPUTS</b>					
Input Threshold Voltage					V
Output Transition High to Low State	$V_{IH}$	–	1.75	2.6	
Output Transition Low to High State	$V_{IL}$	0.8	1.58	–	
Input Current					$\mu\text{A}$
High State ( $V_{IH} = 2.6\text{ V}$ )	$I_{IH}$	–	100	300	
Low State ( $V_{IL} = 0.8\text{ V}$ )	$I_{IL}$	–	20	100	
<b>DRIVE OUTPUT</b>					
Output Voltage					V
Low State ( $I_{\text{sink}} = 10\text{ mA}$ )	$V_{OL}$	–	0.8	1.2	
( $I_{\text{sink}} = 50\text{ mA}$ )		–	1.1	1.5	
( $I_{\text{sink}} = 400\text{ mA}$ )		–	1.8	2.5	
High State ( $I_{\text{source}} = 10\text{ mA}$ )	$V_{OH}$	10.5	11.2	–	
( $I_{\text{source}} = 50\text{ mA}$ )		10.4	11.1	–	
( $I_{\text{source}} = 400\text{ mA}$ )		10	10.8	–	
Output Pull-Down Resistor	$R_{PD}$	–	100	–	$\text{k}\Omega$
<b>SWITCHING CHARACTERISTICS</b> ( $T_A = 25^\circ\text{C}$ )					
Propagation Delay ( $C_L = 1.0\text{ nF}$ )					ns
Logic Input to: Drive Output Rise (10% Input to 10% Output)	$t_{PLH}$ (IN/OUT)	–	55	120	
Drive Output Fall (90% Input to 90% Output)	$t_{PHL}$ (IN/OUT)	–	40	120	
Drive Output Rise Time (10% to 90%)	$t_r$				ns
$C_L = 1.0\text{ nF}$		–	14	30	
$C_L = 2.5\text{ nF}$		–	36	–	
Drive Output Fall Time (90% to 10%)	$t_f$				ns
$C_L = 1.0\text{ nF}$		–	15	30	
$C_L = 2.5\text{ nF}$		–	32	–	
<b>TOTAL DEVICE</b>					
Power Supply Current	$I_{CC}$				mA
Standby (Logic Inputs Grounded)		–	6.0	8.0	
Operating ( $C_L = 1.0\text{ nF}$ Drive Outputs 1 and 2, $f = 100\text{ kHz}$ )		–	10.5	15	
Operating Voltage	$V_{CC}$	6.5	–	18	V

3. Low duty cycle pulse techniques are used during test to maintain junction temperature as close to ambient as possible.

$T_{\text{low}} = 0^\circ\text{C}$  for MC34152,  $-40^\circ\text{C}$  for MC33152,  $-40^\circ\text{C}$  for MC33152V

$T_{\text{high}} = +70^\circ\text{C}$  for MC34152,  $+85^\circ\text{C}$  for MC33152,  $+125^\circ\text{C}$  for MC33152V

NCV33152:  $T_{\text{low}} = -40^\circ\text{C}$ ,  $T_{\text{high}} = +125^\circ\text{C}$ . Guaranteed by design. NCV prefix is for automotive and other applications requiring site and change control.

**勝特力材料 886-3-5753170**  
**勝特力电子(上海) 86-21-54151736**  
**勝特力电子(深圳) 86-755-83298787**  
[Http://www.100y.com.tw](http://www.100y.com.tw)

MC34152, MC33152, NCV33152

勝特力材料 886-3-5753170  
 勝特力电子(上海) 86-21-54151736  
 勝特力电子(深圳) 86-755-83298787  
[Http://www.100y.com.tw](http://www.100y.com.tw)

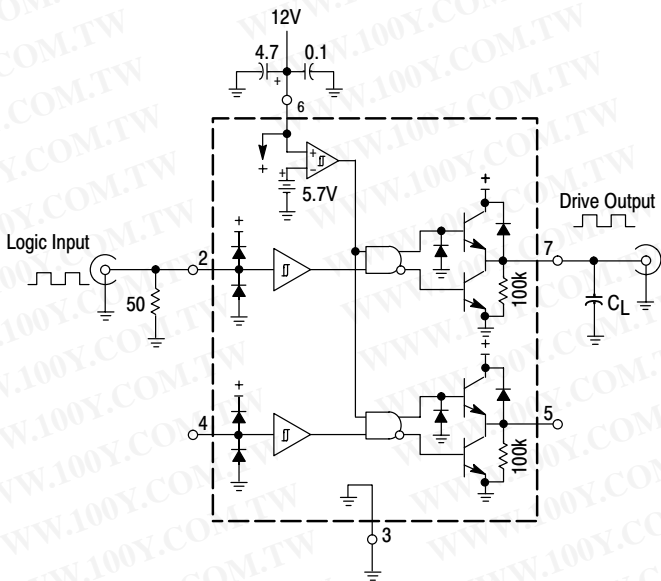

Figure 2. Switching Characteristics Test Circuit

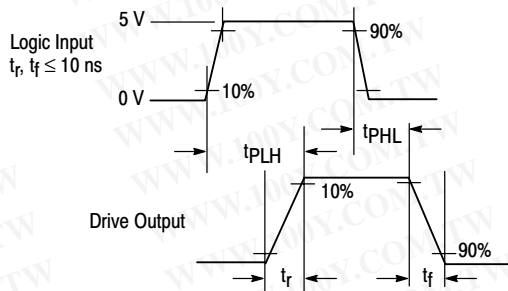

Figure 3. Switching Waveform Definitions

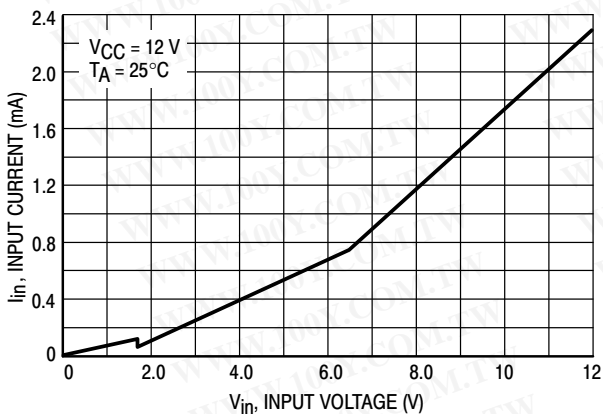

Figure 4. Logic Input Current versus Input Voltage

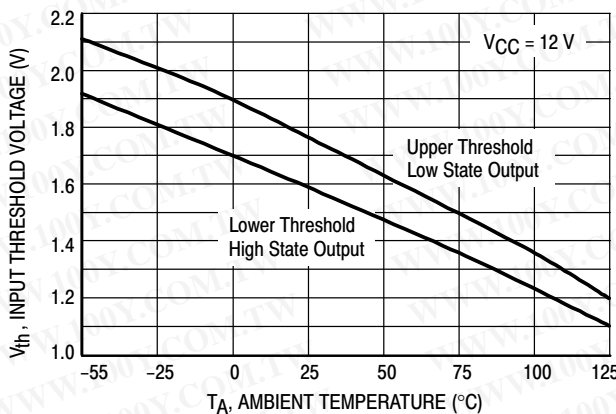

Figure 5. Logic Input Threshold Voltage versus Temperature

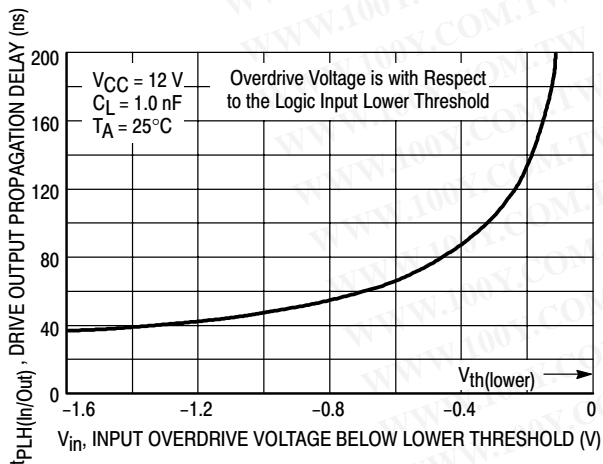

Figure 6. Drive Output High to Low Propagation Delay versus Logic Input Overdrive Voltage

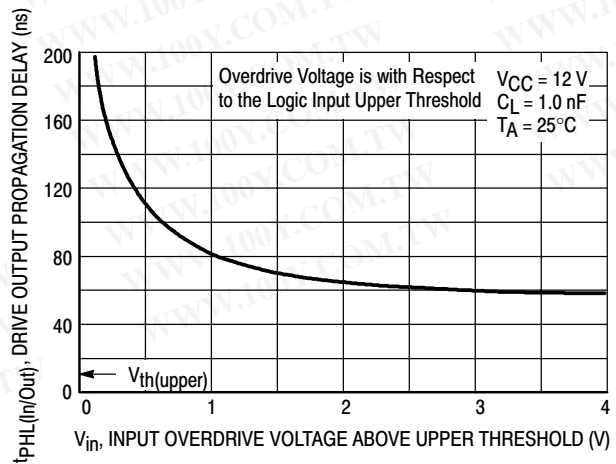

Figure 7. Drive Output Low to High Propagation Delay versus Logic Input Overdrive Voltage

MC34152, MC33152, NCV33152

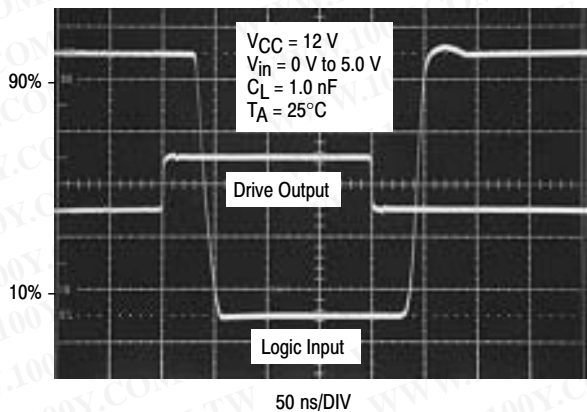

Figure 8. Propagation Delay

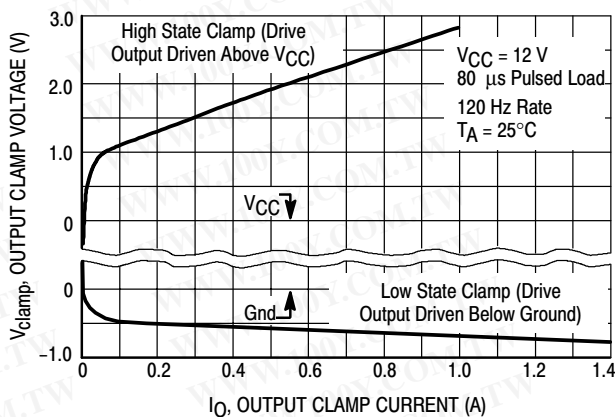

Figure 9. Drive Output Clamp Voltage versus Clamp Current

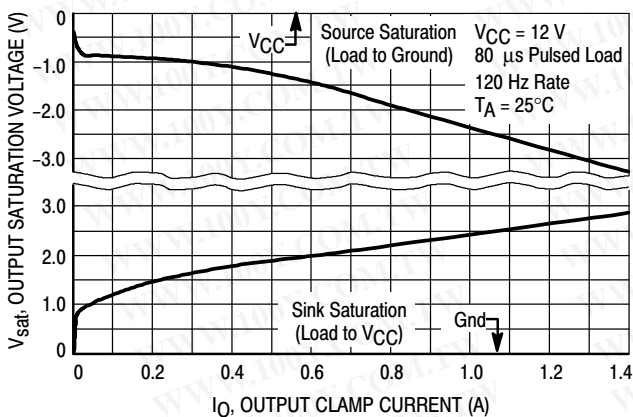

Figure 10. Drive Output Saturation Voltage versus Load Current

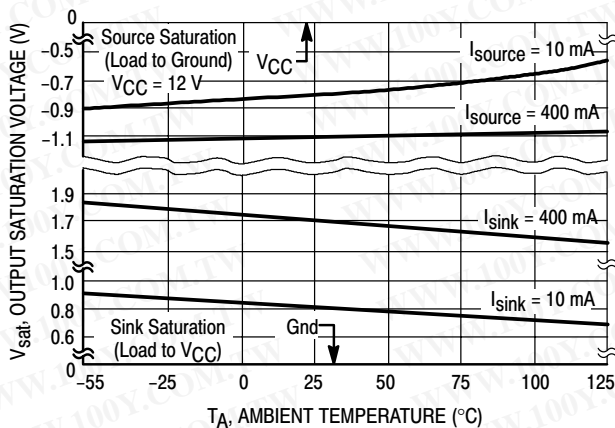

Figure 11. Drive Output Saturation Voltage versus Temperature

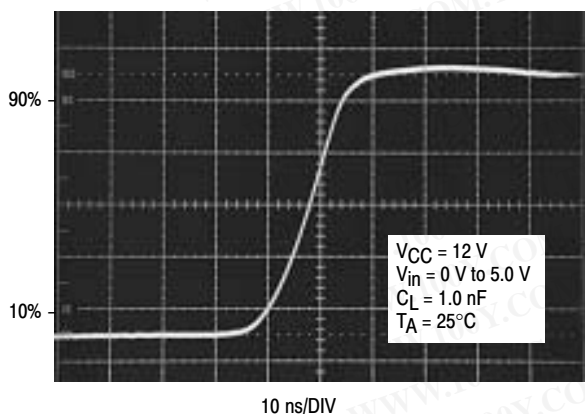

Figure 12. Drive Output Rise Time

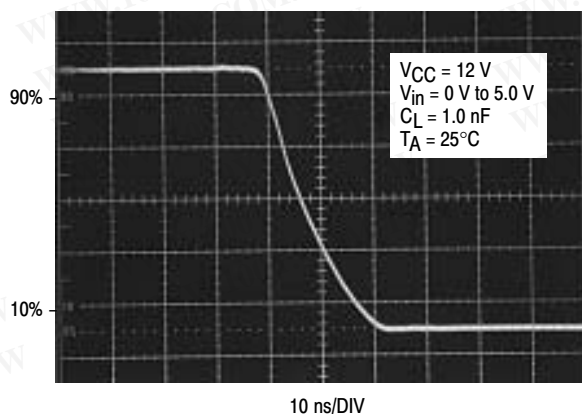

Figure 13. Drive Output Fall Time

MC34152, MC33152, NCV33152

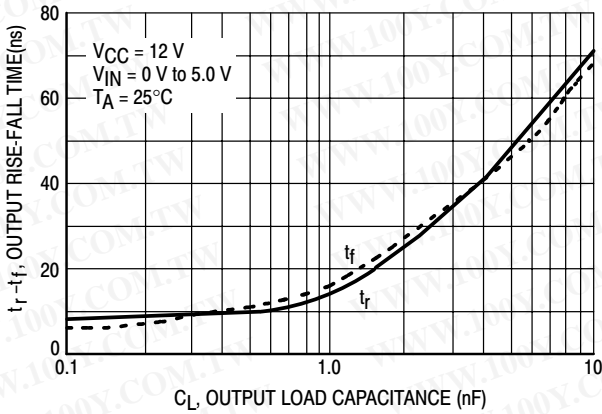

Figure 14. Drive Output Rise and Fall Time versus Load Capacitance

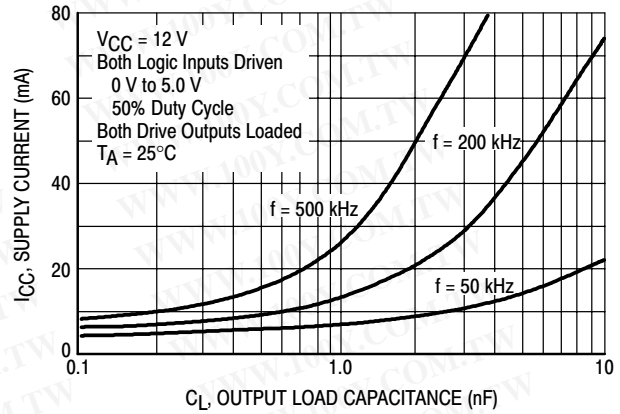

Figure 15. Supply Current versus Drive Output Load Capacitance

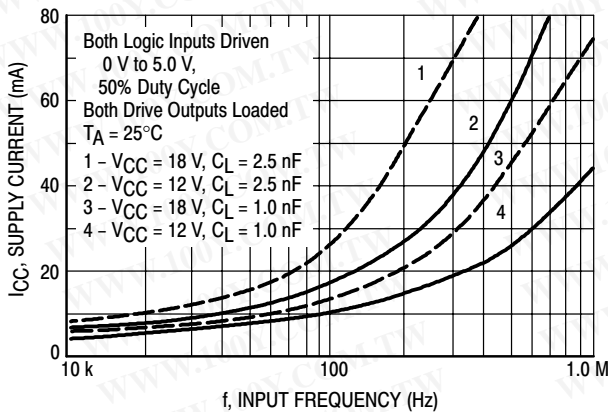

Figure 16. Supply Current versus Input Frequency

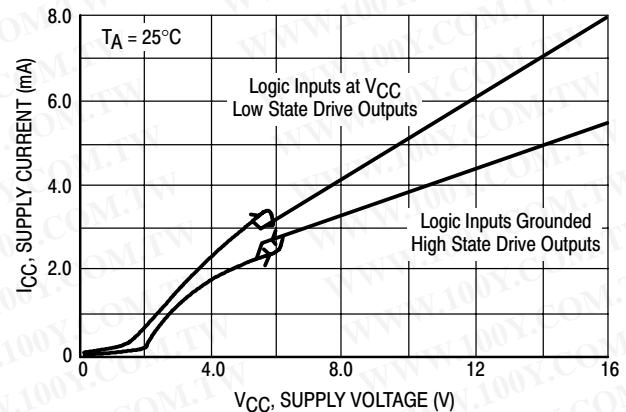

Figure 17. Supply Current versus Supply Voltage

APPLICATIONS INFORMATION

Description

The MC34152 is a dual noninverting high speed driver specifically designed to interface low current digital circuitry with power MOSFETs. This device is constructed with Schottky clamped Bipolar Analog technology which offers a high degree of performance and ruggedness in hostile industrial environments.

Input Stage

The Logic Inputs have 170 mV of hysteresis with the input threshold centered at 1.67 V. The input thresholds are insensitive to VCC making this device directly compatible with CMOS and LSTTL logic families over its entire operating voltage range. Input hysteresis provides fast output switching that is independent of the input signal transition time, preventing output oscillations as the input thresholds are crossed. The inputs are designed to accept a signal amplitude ranging from ground to VCC. This allows the output of one channel to directly drive the input of a second channel for master-slave operation. Each input has a 30 kΩ pull-down resistor so that an unconnected open input will cause the associated Drive Output to be in a known low state.

Output Stage

Each totem pole Drive Output is capable of sourcing and sinking up to 1.5 A with a typical 'on' resistance of 2.4 Ω at 1.0 A. The low 'on' resistance allows high output currents to be attained at a lower VCC than with comparative CMOS drivers. Each output has a 100 kΩ pull-down resistor to keep the MOSFET gate low when VCC is less than 1.4 V. No over current or thermal protection has been designed into the device, so output shorting to VCC or ground must be avoided.

Parasitic inductance in series with the load will cause the driver outputs to ring above VCC during the turn-on transition, and below ground during the turn-off transition. With CMOS drivers, this mode of operation can cause a destructive output latch-up condition. The MC34152 is immune to output latch-up. The Drive Outputs contain an internal diode to VCC for clamping positive voltage transients. When operating with VCC at 18 V, proper power supply bypassing must be observed to prevent the output ringing from exceeding the maximum 20 V device rating. Negative output transients are clamped by the internal NPN pull-up transistor. Since full supply voltage is applied

## MC34152, MC33152, NCV33152

across the NPN pull-up during the negative output transient, power dissipation at high frequencies can become excessive. Figures 20, 21, and 22 show a method of using external Schottky diode clamps to reduce driver power dissipation.

### Undervoltage Lockout

An undervoltage lockout with hysteresis prevents erratic system operation at low supply voltages. The UVLO forces the Drive Outputs into a low state as  $V_{CC}$  rises from 1.4 V to the 5.8 V upper threshold. The lower UVLO threshold is 5.3 V, yielding about 500 mV of hysteresis.

### Power Dissipation

Circuit performance and long term reliability are enhanced with reduced die temperature. Die temperature increase is directly related to the power that the integrated circuit must dissipate and the total thermal resistance from the junction to ambient. The formula for calculating the junction temperature with the package in free air is:

$$T_J = T_A + P_D (R_{\theta JA})$$

where:  $T_J$  = Junction Temperature  
 $T_A$  = Ambient Temperature  
 $P_D$  = Power Dissipation  
 $R_{\theta JA}$  = Thermal Resistance Junction to Ambient

There are three basic components that make up total power to be dissipated when driving a capacitive load with respect to ground. They are:

$$P_D = P_Q + P_C + P_T$$

where:  $P_Q$  = Quiescent Power Dissipation  
 $P_C$  = Capacitive Load Power Dissipation  
 $P_T$  = Transition Power Dissipation

The quiescent power supply current depends on the supply voltage and duty cycle as shown in Figure 17. The device's quiescent power dissipation is:

$$P_Q = V_{CC} (I_{CCL} [1-D] + I_{CCH} [D])$$

where:  $I_{CCL}$  = Supply Current with Low State Drive Outputs  
 $I_{CCH}$  = Supply Current with High State Drive Outputs  
 $D$  = Output Duty Cycle

The capacitive load power dissipation is directly related to the load capacitance value, frequency, and Drive Output voltage swing. The capacitive load power dissipation per driver is:

$$P_C = V_{CC} (V_{OH} - V_{OL}) C_L f$$

where:  $V_{OH}$  = High State Drive Output Voltage  
 $V_{OL}$  = Low State Drive Output Voltage  
 $C_L$  = Load Capacitance  
 $f$  = Frequency

When driving a MOSFET, the calculation of capacitive load power  $P_C$  is somewhat complicated by the changing

gate to source capacitance  $C_{GS}$  as the device switches. To aid in this calculation, power MOSFET manufacturers provide gate charge information on their data sheets. Figure 18 shows a curve of gate voltage versus gate charge for the ON Semiconductor MTM15N50. Note that there are three distinct slopes to the curve representing different input capacitance values. To completely switch the MOSFET 'on,' the gate must be brought to 10 V with respect to the source. The graph shows that a gate charge  $Q_g$  of 110 nC is required when operating the MOSFET with a drain to source voltage  $V_{DS}$  of 400 V.

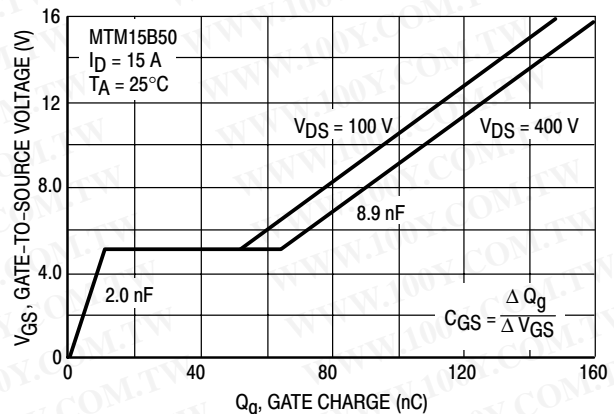

Figure 18. Gate-to-Source Voltage versus Gate charge

The capacitive load power dissipation is directly related to the required gate charge, and operating frequency. The capacitive load power dissipation per driver is:

$$P_C(\text{MOSFET}) = V_{CC} Q_g f$$

The flat region from 10 nC to 55 nC is caused by the drain-to-gate Miller capacitance, occurring while the MOSFET is in the linear region dissipating substantial amounts of power. The high output current capability of the MC34152 is able to quickly deliver the required gate charge for fast power efficient MOSFET switching. By operating the MC34152 at a higher  $V_{CC}$ , additional charge can be provided to bring the gate above 10 V. This will reduce the 'on' resistance of the MOSFET at the expense of higher driver dissipation at a given operating frequency.

The transition power dissipation is due to extremely short simultaneous conduction of internal circuit nodes when the Drive Outputs change state. The transition power dissipation per driver is approximately:

$$P_T \approx V_{CC} (1.08 V_{CC} C_L f - 8 \times 10^{-4})$$

$P_T$  must be greater than zero.

Switching time characterization of the MC34152 is performed with fixed capacitive loads. Figure 14 shows that for small capacitance loads, the switching speed is limited by transistor turn-on/off time and the slew rate of the internal nodes. For large capacitance loads, the switching speed is limited by the maximum output current capability of the integrated circuit.

## MC34152, MC33152, NCV33152

### LAYOUT CONSIDERATIONS

High frequency printed circuit layout techniques are imperative to prevent excessive output ringing and overshoot. **Do not attempt to construct the driver circuit on wire-wrap or plug-in prototype boards.** When driving large capacitive loads, the printed circuit board must contain a low inductance ground plane to minimize the voltage spikes induced by the high ground ripple currents. All high current loops should be kept as short as possible using heavy copper runs to provide a low impedance high frequency path. For optimum drive

performance, it is recommended that the initial circuit design contains dual power supply bypass capacitors connected with short leads as close to the VCC pin and ground as the layout will permit. Suggested capacitors are a low inductance 0.1  $\mu\text{F}$  ceramic in parallel with a 4.7  $\mu\text{F}$  tantalum. Additional bypass capacitors may be required depending upon Drive Output loading and circuit layout.

**Proper printed circuit board layout is extremely critical and cannot be over emphasized.**

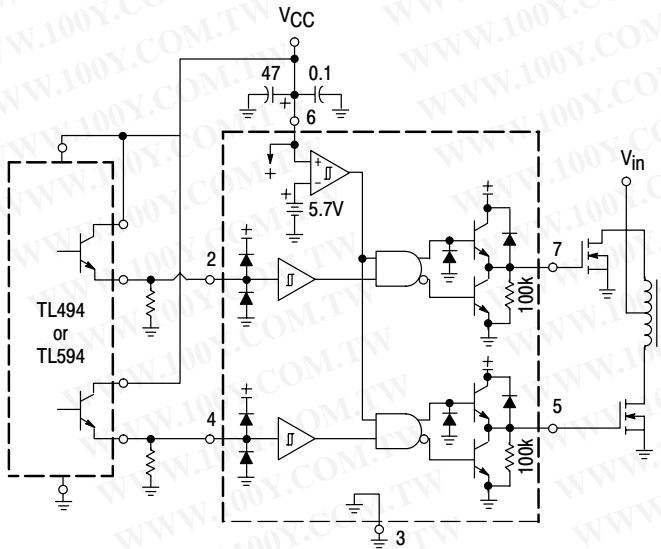

The MC34152 greatly enhances the drive capabilities of common switching regulators and CMOS/TTL logic devices.

**Figure 19. Enhanced System Performance with Common Switching Regulators**

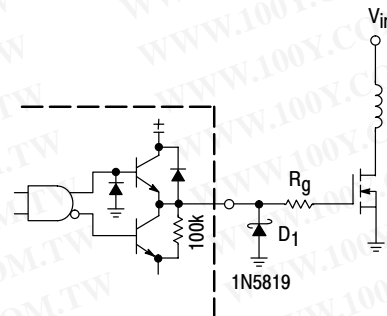

Series gate resistor  $R_g$  may be needed to damp high frequency parasitic oscillations caused by the MOSFET input capacitance and any series wiring inductance in the gate-source circuit.  $R_g$  will decrease the MOSFET switching speed. Schottky diode  $D_1$  can reduce the driver's power dissipation due to excessive ringing, by preventing the output pin from being driven below ground.

**Figure 20. MOSFET Parasitic Oscillations**

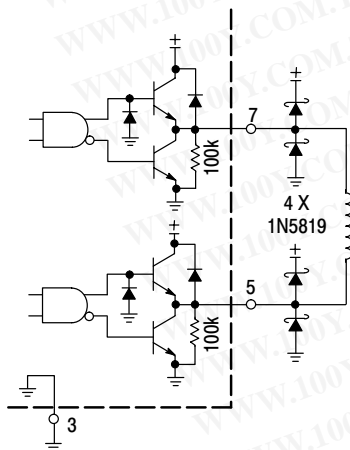

Output Schottky diodes are recommended when driving inductive loads at high frequencies. The diodes reduce the driver's power dissipation by preventing the output pins from being driven above  $V_{CC}$  and below ground.

**Figure 21. Direct Transformer Drive**

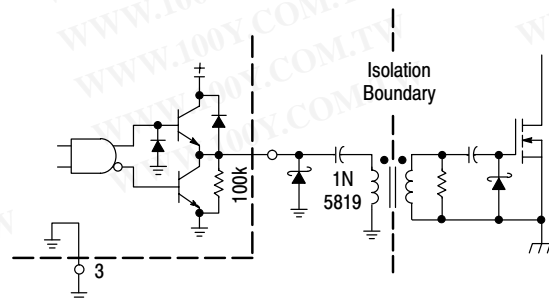

**Figure 22. Isolated MOSFET Drive**

MC34152, MC33152, NCV33152

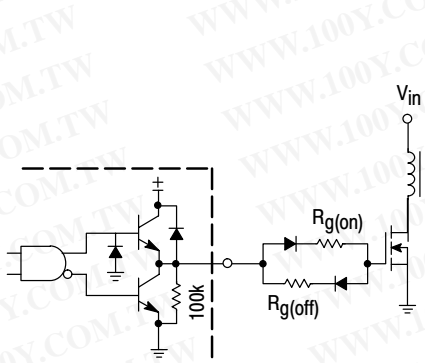

In noise sensitive applications, both conducted and radiated EMI can be reduced significantly by controlling the MOSFET's turn-on and turn-off times.

Figure 23. Controlled MOSFET Drive

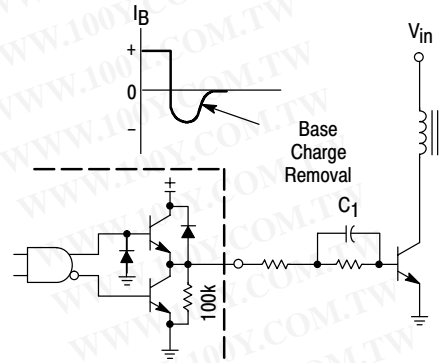

The totem-pole outputs can furnish negative base current for enhanced transistor turn-off, with the addition of capacitor C1.

Figure 24. Bipolar Transistor Drive

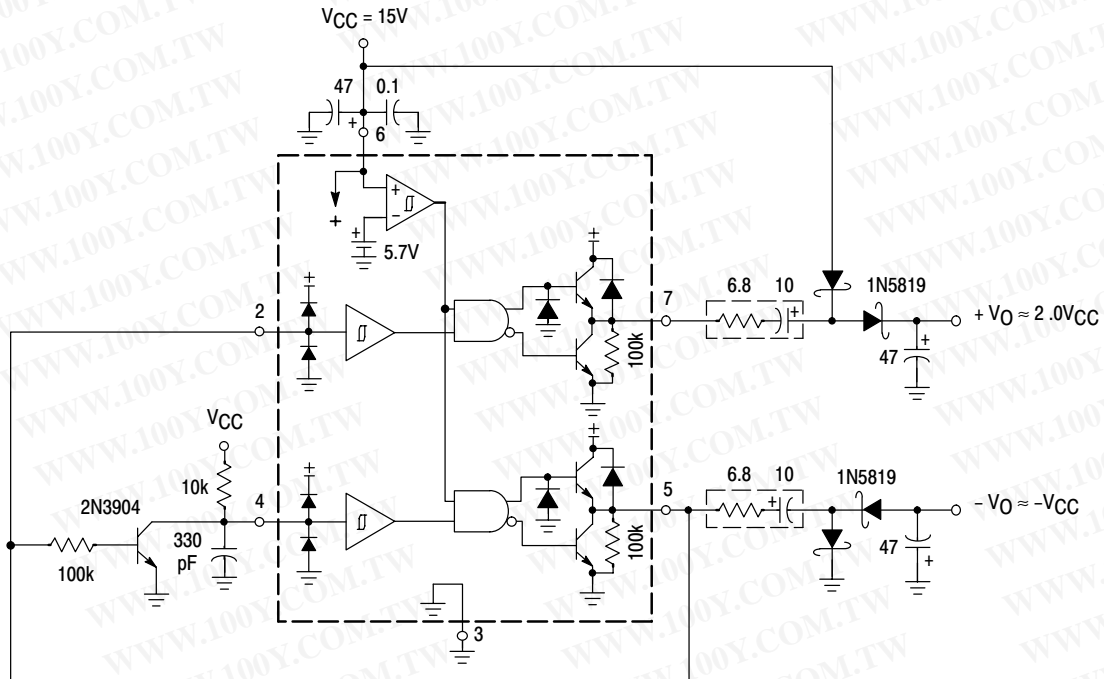

The capacitor's equivalent series resistance limits the Drive Output Current to 1.5 A. An additional series resistor may be required when using tantalum or other low ESR capacitors.

Figure 25. Dual Charge Pump Converter

Output Load Regulation		
I <sub>O</sub> (mA)	+V <sub>O</sub> (V)	-V <sub>O</sub> (V)
0	27.7	-13.3
1.0	27.4	-12.9
10	26.4	-11.9
20	25.5	-11.2
30	24.6	-10.5
50	22.6	-9.4

MC34152, MC33152, NCV33152

PACKAGE DIMENSIONS

P SUFFIX  
 PLASTIC PACKAGE  
 CASE 626-05  
 ISSUE L

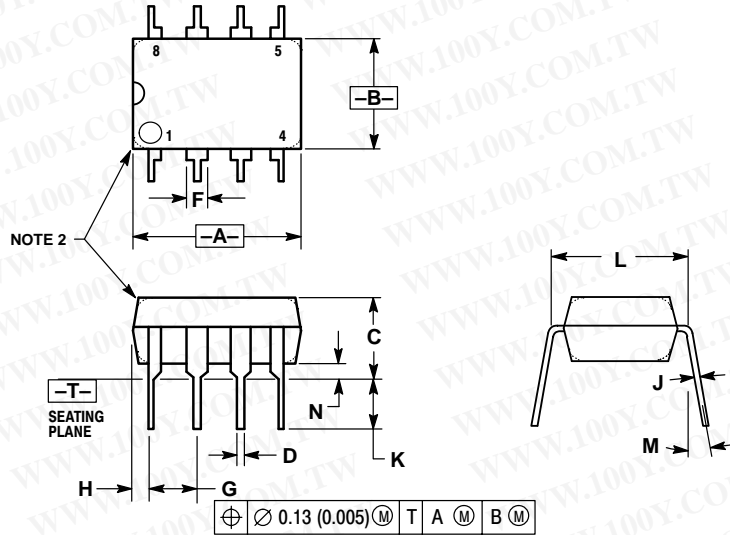

NOTES:

1. DIMENSION L TO CENTER OF LEAD WHEN FORMED PARALLEL.
2. PACKAGE CONTOUR OPTIONAL (ROUND OR SQUARE CORNERS).
3. DIMENSIONING AND TOLERANCING PER ANSI Y14.5M, 1982.

DIM	MILLIMETERS		INCHES	
	MIN	MAX	MIN	MAX
A	9.40	10.16	0.370	0.400
B	6.10	6.60	0.240	0.260
C	3.94	4.45	0.155	0.175
D	0.38	0.51	0.015	0.020
F	1.02	1.78	0.040	0.070
G	2.54 BSC		0.100 BSC	
H	0.76	1.27	0.030	0.050
J	0.20	0.30	0.008	0.012
K	2.92	3.43	0.115	0.135
L	7.62 BSC		0.300 BSC	
M	--- 10°		--- 10°	
N	0.76	1.01	0.030	0.040

# MC34152, MC33152, NCV33152

## PACKAGE DIMENSIONS

**D SUFFIX**  
**PLASTIC PACKAGE**  
**CASE 751-07**  
**(SO-8)**  
**ISSUE W**

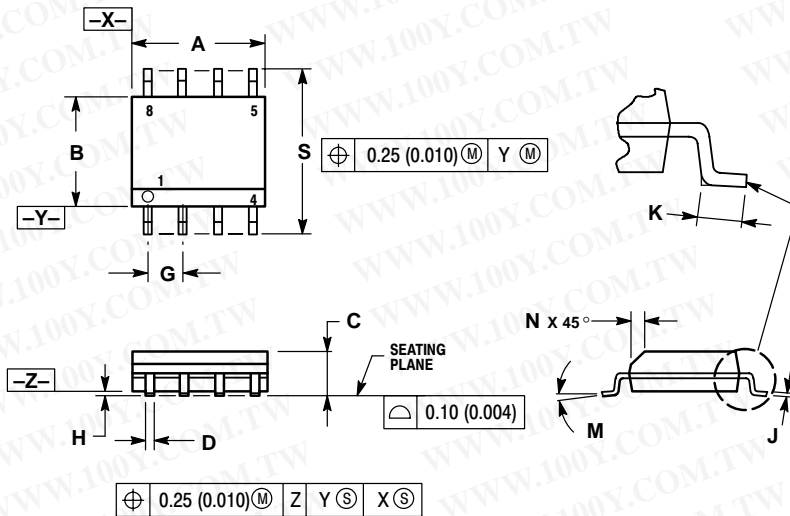

### NOTES:

1. DIMENSIONING AND TOLERANCING PER ANSI Y14.5M, 1982.
2. CONTROLLING DIMENSION: MILLIMETER.
3. DIMENSION A AND B DO NOT INCLUDE MOLD PROTRUSION.
4. MAXIMUM MOLD PROTRUSION 0.15 (0.006) PER SIDE.
5. DIMENSION D DOES NOT INCLUDE DAMBAR PROTRUSION. ALLOWABLE DAMBAR PROTRUSION SHALL BE 0.127 (0.005) TOTAL IN EXCESS OF THE D DIMENSION AT MAXIMUM MATERIAL CONDITION.

DIM	MILLIMETERS		INCHES	
	MIN	MAX	MIN	MAX
A	4.80	5.00	0.189	0.197
B	3.80	4.00	0.150	0.157
C	1.35	1.75	0.053	0.069
D	0.33	0.51	0.013	0.020
G	1.27 BSC		0.050 BSC	
H	0.10	0.25	0.004	0.010
J	0.19	0.25	0.007	0.010
K	0.40	1.27	0.016	0.050
M	0°	8°	0°	8°
N	0.25	0.50	0.010	0.020
S	5.80	6.20	0.228	0.244

勝特力材料 886-3-5753170  
 勝特力电子(上海) 86-21-54151736  
 勝特力电子(深圳) 86-755-83298787  
[Http://www.100y.com.tw](http://www.100y.com.tw)