



Precision, 16-Channel/Dual 8-Channel, Low-Voltage, CMOS Analog Multiplexers

General Description

The MAX396/MAX397 low-voltage, CMOS analog multiplexers (muxes) offer low on-resistance (100Ω max), which is matched to within 6Ω between switches and remains flat over the specified signal range (10Ω max). They also offer low leakage over temperature (input off-leakage current less than 1nA at +85°C) and fast switching speeds (transition time less than 250ns). The MAX396 is a 16-channel device, and the MAX397 is a dual 8-channel device.

The MAX396/MAX397 are fabricated with Maxim's low-voltage silicon-gate process. Design improvements yield extremely low charge injection (5pC max) and guarantee electrostatic-discharge (ESD) protection greater than 2000V per Method 3015.7

These muxes operate with a single +2.7V to +16V supply or with ±2.7V to ±8V dual supplies, while retaining CMOS-logic input compatibility and fast switching. The MAX396/MAX397 are pin compatible with the industry-standard MAX306/MAX307, DG406/DG407, and DG506A/DG507A.

Applications

- Sample-and-Hold Circuits
- Automatic Test Equipment
- Avionics
- Communications Systems
- Battery-Operated Equipment
- Audio Signal Routing
- Low-Voltage Data Acquisition Systems
- Industrial Process Control Systems

Features

- Pin Compatible with MAX306/MAX307, DG406/DG407, DG506A/DG507A
- Single-Supply Operation (+2.7V to +16V)
Dual-Supply Operation (±2.7V to ±8V)
- Low On-Resistance (100Ω max)
- Guaranteed RON Match Between Channels (6Ω max)
- Guaranteed RON Flatness over Specified Signal Range (10Ω max)
- Guaranteed Low Charge Injection (5pC max)
- Input Off-Leakage Current < 1nA at +85°C
- Output Off-Leakage Current < 2.5nA at +85°C
- Low Power Consumption < 10μW
- TTL/CMOS Compatible

Ordering Information

PART	TEMP. RANGE	PIN-PACKAGE
MAX396CPI	0°C to +70°C	28 Plastic DIP
MAX396CWI	0°C to +70°C	28 Wide SO
MAX396CAI	0°C to +70°C	28 SSOP
MAX396CQI	0°C to +70°C	28 PLCC**
MAX396C/D	0°C to +70°C	Dice*

Ordering Information continued on last page.

*Contact factory for dice specifications.

**Contact factory for package availability.

Pin Configurations/Functional Diagrams/Truth Tables

TOP VIEW

DIP/SO
N.C. = NO INTERNAL CONNECTION

MAX396 16-CHANNEL SINGLE-ENDED MULTIPLEXER

MAX396

A3	A2	A1	A0	EN	ON SWITCH
X	X	X	X	0	NONE
0	0	0	0	1	1
0	0	0	1	1	2
0	0	1	0	1	3
0	0	1	1	1	4
0	1	0	0	1	5
0	1	0	1	1	6
0	1	1	0	1	7
0	1	1	1	1	8
1	0	0	0	1	9
1	0	0	1	1	10
1	0	1	0	1	11
1	0	1	1	1	12
1	1	0	0	1	13
1	1	0	1	1	14
1	1	1	0	1	15
1	1	1	1	1	16

LOGIC "0" = V_{AL} ≤ 0.8V, LOGIC "1" = V_{AH} ≥ 2.4V

Continued at end of data sheet.

MAX396/MAX397

Precision, 16-Channel/Dual 8-Channel, Low-Voltage, CMOS Analog Multiplexers

ABSOLUTE MAXIMUM RATINGS

(Voltage referenced to GND, unless otherwise noted.)

V+	-0.3V to +17V
V-	+0.3V to -17V
V+ to V-	-0.3V to +17V
Voltage into Any Terminal (Note 1)	(V- - 2V) to (V+ + 2V) or 30mA (whichever occurs first)
Current into Any Terminal	±30mA
Peak Current into Any Terminal	±50mA
Continuous Power Dissipation (T _A = +70°C)	
Plastic DIP (derate 14.29mW/°C above +70°C)	1143mW
Wide SO (derate 12.50mW/°C above +70°C)	1000mW

SSOP (derate 9.52mW/°C above +70°C)	762mW
PLCC (derate 10.53mW/°C above +70°C)	842mW
CERDIP (derate 16.67mW/°C above +70°C)	1333mW
Operating Temperature Ranges	
MAX39_C_I	0°C to +70°C
MAX39_E_I	-40°C to +85°C
MAX39_MJI	-55°C to +125°C
Storage Temperature Range	-65°C to +150°C
Lead Temperature (soldering, 10sec)	+300°C

Note 1: Signals on any terminal exceeding V+ or V- are clamped by internal diodes. Limit forward current to maximum current rating.

Stresses beyond those listed under "Absolute Maximum Ratings" may cause permanent damage to the device. These are stress ratings only, and functional operation of the device at these or any other conditions beyond those indicated in the operational sections of the specifications is not implied. Exposure to absolute maximum rating conditions for extended periods may affect device reliability.

ELECTRICAL CHARACTERISTICS—Dual Supplies

(V+ = +5V ±10%, V- = -5V ±10%, GND = 0V, V_{AH} = V_{ENH} = 2.4V, V_{AL} = V_{ENL} = 0.8V, T_A = T_{MIN} to T_{MAX}, unless otherwise noted.)

PARAMETER	SYMBOL	CONDITIONS	MIN	TYP (Note 2)	MAX	UNITS			
SWITCH									
Analog Signal Range	V _{COM} , V _{NO}	(Note 3)	V-		V+	V			
Channel On-Resistance	R _{ON}	I _{NO} = 1mA, V _{COM} = ±3.5V	T _A = +25°C		60	100	Ω		
			T _A = T _{MIN} to T _{MAX}			125			
On-Resistance Matching Between Channels (Note 4)	ΔR _{ON}	I _{NO} = 1mA, V _{COM} = ±3.5V, V+ = 5V, V- = -5V	T _A = +25°C		1.8	6	Ω		
			T _A = T _{MIN} to T _{MAX}			8			
On-Resistance Flatness (Note 5)	R _{FLAT(ON)}	I _{NO} = 1mA, V _{COM} = ±3V, V+ = 5V, V- = -5V	T _A = +25°C		5	10	Ω		
			T _A = T _{MIN} to T _{MAX}			13			
NO Off-Leakage Current (Note 6)	I _{NO(OFF)}	V _{NO} = ±4.5V, V _{COM} = ±4.5V, V+ = 5.5V, V- = -5.5V	T _A = +25°C		-0.1	0.03	0.1	nA	
			T _A = T _{MIN} to T _{MAX}	C, E	-1.0	1.0			
				M	-10	10			
COM Off-Leakage Current (Note 6)	I _{COM(OFF)}	V _{COM} = ±4.5V, V _{NO} = ±4.5V, V+ = 5.5V, V- = -5.5V	MAX396	T _A = +25°C		-0.2	0.05	0.2	nA
				T _A = T _{MIN} to T _{MAX}	C, E	-2.5	2.5		
					M	-40	40		
		V _{COM} = ±4.5V, V _{NO} = ±4.5V, V+ = 5.5V, V- = -5.5V	MAX397	T _A = +25°C		-0.1	0.03	0.1	
				T _A = T _{MIN} to T _{MAX}	C, E	-2.5	2.5		
					M	-20	20		
COM On-Leakage Current (Note 6)	I _{COM(ON)}	V _{COM} = ±4.5V, V _{NO} = 4.5V,	MAX396	T _A = +25°C		-0.4	0.09	0.4	nA
				T _A = T _{MIN} to T _{MAX}	C, E	-5	5		
					M	-60	60		
		V _{COM} = ±4.5V, V _{NO} = 4.5V,	MAX397	T _A = +25°C		-0.2	0.05	0.2	
				T _A = T _{MIN} to T _{MAX}	C, E	-2.5	2.5		
					M	-30	30		

Precision, 16-Channel/Dual 8-Channel, Low-Voltage, CMOS Analog Multiplexers

MAX396/MAX397

ELECTRICAL CHARACTERISTICS—Dual Supplies (continued)

(V+ = +5V ±10%, V- = -5V ±10%, GND = 0V, V_{AH} = V_{ENH} = 2.4V, V_{AL} = V_{ENL} = 0.8V, T_A = T_{MIN} to T_{MAX}, unless otherwise noted.)

PARAMETER	SYMBOL	CONDITIONS	MIN	TYP (Note 2)	MAX	UNITS
DIGITAL LOGIC INPUT						
Logic High Input Voltage	V _{AH} , V _{ENH}		2.4			V
Logic Low Input Voltage	V _{AL} , V _{ENL}				0.8	V
Input Current with Input Voltage High	I _{AH} , I _{ENH}	V _A = V _{EN} = 2.4V	-0.1		0.1	μA
Input Current with Input Voltage Low	I _{AL} , I _{ENL}	V _A = V _{EN} = 0.8V	-0.1		0.1	μA
SUPPLY						
Power-Supply Range			±3		±8	V
Positive Supply Current	I ₊	V _{EN} = V _A = 0V/V+, V ₊ = 5.5V, V ₋ = -5.5V	T _A = +25°C	-1	1	μA
Negative Supply Current	I ₋	V _{EN} = V _A = 0V/V+, V ₊ = 5.5V, V ₋ = -5.5V		-1	1	μA
Ground Current	I _{GND}	V _{EN} = V _A = 0V/V+, V ₊ = 5.5V, V ₋ = -5.5V	T _A = +25°C	-1	1	μA
			T _A = T _{MIN} to T _{MAX}	-1	1	
DYNAMIC						
Transition Time	t _{TRANS}	Figure 2	T _A = +25°C	95	150	ns
			T _A = T _{MIN} to T _{MAX}		250	
Break-Before-Make Interval	t _{OPEN}	Figure 4	T _A = +25°C	5	70	ns
Enable Turn-On Time	t _{ON(EN)}	Figure 3	T _A = +25°C	100	150	ns
			T _A = T _{MIN} to T _{MAX}		250	
Enable Turn-Off Time	t _{OFF(EN)}	Figure 3	T _A = +25°C	55	150	ns
			T _A = T _{MIN} to T _{MAX}		200	
Charge Injection (Note 3)	V _{CTE}	C _L = 100pF, V _{NO} = 0V, Figure 5	T _A = +25°C	2	5	pC
Off-Isolation (Note 7)	V _{ISO}	V _{EN} = 0V, R _L = 1kΩ, f = 100kHz	T _A = +25°C	-75		dB
Crosstalk Between Channels	V _{CT}	V _{EN} = 2.4V, f = 100kHz, V _{NO} = 1V _{p-p} , R _L = 1kΩ, Figure 7	T _A = +25°C	-92		dB
Logic Input Capacitance	C _{IN}	f = 1MHz	T _A = +25°C	8		pF
NO Off-Capacitance	C _{NO(OFF)}	f = 1MHz, V _{EN} = V _{COM} = 0V	T _A = +25°C	11		pF
COM Off-Capacitance	C _{COM(OFF)}	f = 1MHz, V _{EN} = V _{COM} = 0V	MAX396	T _A = +25°C	80	pF
			MAX397		40	
COM On-Capacitance	C _{COM(ON)}	f = 1MHz, V _{EN} = V _{COM} = 0V	MAX396	T _A = +25°C	90	pF
			MAX397		68	

勝特力材料 886-3-5753170
 勝特力电子(上海) 86-21-54151736
 勝特力电子(深圳) 86-755-83298787
[Http://www.100y.com.tw](http://www.100y.com.tw)

Precision, 16-Channel/Dual 8-Channel, Low-Voltage, CMOS Analog Multiplexers

ELECTRICAL CHARACTERISTICS—Single +5V Supply

(V+ = +5V ±10%, V- = 0V, GND = 0V, VAH = VENH = 2.4V, VAL = VENL = 0.8V, TA = TMIN to TMAX, unless otherwise noted.)

PARAMETER	SYMBOL	CONDITIONS		MIN	TYP (Note 2)	MAX	UNITS
SWITCH							
Analog Signal Range	V _{COM} , V _{NO}	(Note 3)		V-		V+	V
On-Resistance	R _{ON}	I _{NO} = 1mA, V _{COM} = 3.5V, V+ = 4.5V	TA = +25°C TA = T _{MIN} to T _{MAX}		120	225 280	Ω
On-Resistance Matching Between Channels (Note 4)	ΔR _{ON}	I _{NO} = 1mA, V _{COM} = 3.5V, V+ = 4.5V	TA = +25°C TA = T _{MIN} to T _{MAX}		2	10 12	Ω
On-Resistance Flatness	R _{FLAT}	I _{NO} = 1mA; V _{COM} = 3V, 2V, 1V; V+ = 5V	TA = +25°C TA = T _{MIN} to T _{MAX}		5	16 20	Ω
NO Off-Leakage Current (Note 8)	I _{NO(OFF)}	V _{NO} = 4.5V, V _{COM} = 0V, V+ = 5.5V	TA = +25°C TA = T _{MIN} to T _{MAX}	C, E M	-1.0 -10	0.03 10	nA
COM Off-Leakage Current (Note 8)	I _{COM(OFF)}	V _{COM} = 4.5V, V _{NO} = 0V, V+ = 5.5V	MAX396 TA = +25°C TA = T _{MIN} to T _{MAX}	C, E M	-0.2 -2.5 -40	0.05 2.5 40	nA
COM On-Leakage Current (Note 8)	I _{COM(ON)}	V _{COM} = 4.5V, V _{NO} = 4.5V, V+ = 5.5V	MAX396 TA = +25°C TA = T _{MIN} to T _{MAX}	C, E M	-0.4 -5 -60	0.09 5 60	nA
			MAX397 TA = +25°C TA = T _{MIN} to T _{MAX}	C, E M	-0.2 -2.5 -30	0.04 2.5 30	nA
DIGITAL LOGIC INPUT							
Logic High Input Voltage	V _{AH} , V _{ENH}			2.4			V
Logic Low Input Voltage	V _{AL} , V _{ENL}					0.8	V
Input Current with Input Voltage High	I _{AH} , I _{ENH}	VA = VEN = 2.4V		-0.1	0.001	0.1	μA
Input Current with Input Voltage Low	I _{AL} , I _{ENL}	VA = 0V, VEN = 0.8V		-0.1	0.001	0.1	μA
SUPPLY							
Power-Supply Range				2.7		15	V
Positive Supply Current	I+	V _{EN} = VA = 0V, V+; V+ = 5.5V; V- = 0V		-1.0	0.06	1.0	μA
Negative Supply Current	I-	V _{EN} = VA = 0V, V+; V+ = 5.5V; V- = 0V		-1.0	0.08	1.0	μA
I _{GND} Supply Current	I _{GND}	V _{EN} = V+, 0V; VA = 0V; V+ = 5.5V; V- = 0V	TA = +25°C TA = T _{MIN} to T _{MAX}	-1.0	0.08	1.0	μA

勝特力材料 886-3-5753170
 勝特力电子(上海) 86-21-54151736
 勝特力电子(深圳) 86-755-83298787
[Http://www.100y.com.tw](http://www.100y.com.tw)

Precision, 16-Channel/Dual 8-Channel, Low-Voltage, CMOS Analog Multiplexers

MAX396/MAX397

ELECTRICAL CHARACTERISTICS—Single +5V Supply (continued)

(V+ = +5V ±10%, V- = 0V, GND = 0V, VAH = VENH = 2.4V, VAL = VENL = 0.8V, TA = TMIN to TMAX, unless otherwise noted.)

PARAMETER	SYMBOL	CONDITIONS	MIN	TYP (Note 2)	MAX	UNITS
DYNAMIC						
Transition Time (Note 3)	tTRANS	VNO = 3V, Figure 2	TA = +25°C	105	245	ns
			TA = TMIN to TMAX		350	
Break-Before-Make Interval	tOPEN	(Note 3)	TA = +25°C	10	65	ns
Enable Turn-On Time (Note 3)	tON(EN)		TA = +25°C	125	200	ns
			TA = TMIN to TMAX		275	
Enable Turn-Off Time (Note 3)	tOFF(EN)		TA = +25°C	100	125	ns
			TA = TMIN to TMAX		200	
Charge Injection (Note 3)	VCTE	CL = 100pF, VNO = 0V, Figure 5	TA = +25°C	1.5	5	pC

ELECTRICAL CHARACTERISTICS—Single +3V Supply

(V+ = +3V ±10%, V- = 0V, GND = 0V, VAH = VENH = 2.4V, VAL = VENL = 0.8V, TA = TMIN to TMAX, unless otherwise noted.)

PARAMETER	SYMBOL	CONDITIONS	MIN	TYP (Note 2)	MAX	UNITS
SWITCH						
Analog Signal Range	VANALOG	(Note 3)	V-		V+	V
On-Resistance	RON	INO = 1mA, VCOM = 1.5V, V+ = 3V	TA = +25°C	315	550	Ω
			TA = TMIN to TMAX		650	
DYNAMIC						
Transition Time (Note 3)	tTRANS	Figure 2, VIN = 2.4V, VN01 = 1.5V, VN08 = 0V	TA = +25°C	230	575	ns
			TA = TMIN to TMAX		750	
Enable Turn-On Time (Note 3)	tON(EN)	Figure 3, VINH = 2.4V, VINL = 0V, VN01 = 1.5V	TA = +25°C	260	500	ns
Enable Turn-Off Time (Note 3)	tOFF(EN)	Figure 3, VINH = 2.4V, VINL = 0V, VN01 = 1.5V	TA = +25°C	135	400	ns
Charge Injection (Note 3)	VCTE	CL = 100pF, VNO = 0V, Figure 5	TA = +25°C	1	5	pC

Note 2: The algebraic convention, where the most negative value is a minimum and the most positive value a maximum, is used in this data sheet.

Note 3: Guaranteed by design.

Note 4: $\Delta R_{ON} = R_{ON(MAX)} - R_{ON(MIN)}$.

Note 5: Flatness is defined as the difference between the maximum and minimum value of on-resistance as measured over the specified analog signal ranges, i.e., VNO = 3V to 0V and 0V to -3V.

Note 6: Leakage parameters are 100% tested at maximum rated hot operating temperature, and guaranteed by correlation at +25°C.

Note 7: Worst-case isolation is on channel 4 because of its proximity to the COM pin. Off-isolation = $20 \log V_{COM}/V_{NO}$. VCOM = output, VNO = input to off switch.

Note 8: Leakage testing at single supply is guaranteed by correlation testing with dual supplies.

Precision, 16-Channel/Dual 8-Channel, Low-Voltage, CMOS Analog Multiplexers

Typical Operating Characteristics

($T_A = +25^\circ\text{C}$, unless otherwise noted.)

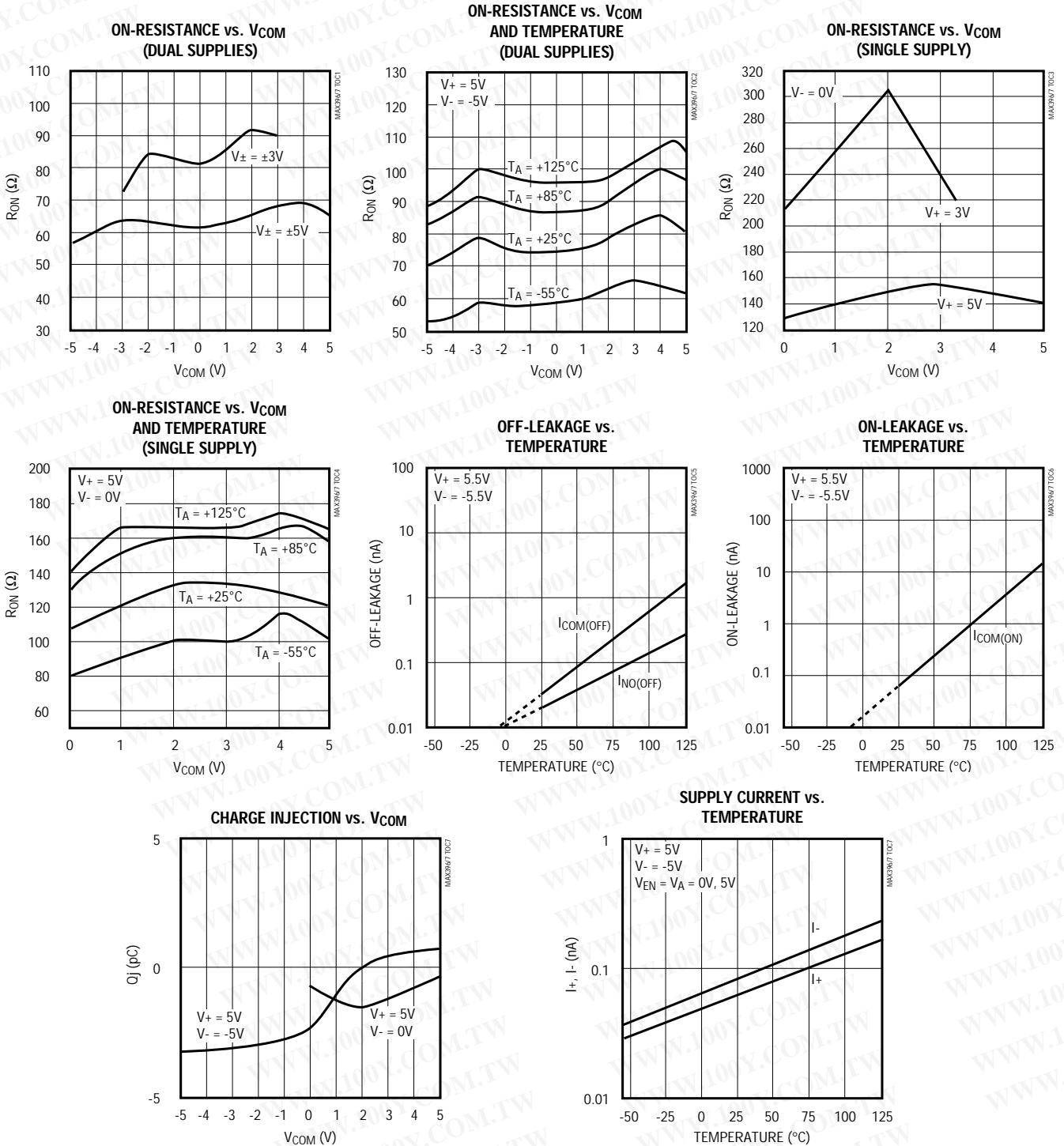

勝特力材料 886-3-5753170
 勝特力电子(上海) 86-21-54151736
 勝特力电子(深圳) 86-755-83298787
[Http://www.100y.com.tw](http://www.100y.com.tw)

Precision, 16-Channel/Dual 8-Channel, Low-Voltage, CMOS Analog Multiplexers

Pin Description

MAX396/MAX397

PIN		NAME	FUNCTION
MAX396	MAX397		
1	1	V+	Positive Supply-Voltage Input
2, 3, 13	—	N.C.	No Internal Connection
—	2	COMB	Analog Signal B Output* (bidirectional)
—	3, 13, 14	N.C.	No Internal Connection
4–11	—	NO16–NO9	Analog Signal Inputs* (bidirectional)
—	4–11	NO8B–NO1B	Analog Signal B Inputs* (bidirectional)
12	12	GND	Logic Ground
14–17	—	A3–A0	Logic Address Inputs
—	15, 16, 17	A2, A1, A0	Logic Address Inputs
18	18	EN	Logic Enable Input
19–26	—	NO1–NO8	Analog Signal Inputs* (bidirectional)
—	19–26	NO1A–NO8A	Analog Signal A Inputs* (bidirectional)
27	27	V-	Negative Supply-Voltage Input
28	—	COM	Analog Signal Output* (bidirectional)
—	28	COMA	Analog Signal A Output* (bidirectional)

*Analog signal inputs and outputs are names of convenience only; they are identical and interchangeable.

Applications Information

Operation with Supply Voltages Other than $\pm 5V$

Using supply voltages less than $\pm 5V$ reduces the analog signal range. The MAX396/MAX397 multiplexers (muxes) operate with $\pm 3V$ to $\pm 8V$ bipolar supplies or with a $+3V$ to $+15V$ single supply. Connect V- to GND when operating with a single supply. Both devices can also operate with unbalanced supplies, such as $+10V$ and $-5V$. The *Typical Operating Characteristics* graphs show typical on-resistance with $\pm 3V$, $\pm 5V$, $+3V$, and $+5V$ supplies. (Switching times increase by a factor of two or more for operation at $5V$ or below.)

These muxes operate with a single supply as low as $1V$, although on-resistance and switching times become extremely high. Performance is not guaranteed below $2.7V$. This is useful information only because it assures proper switch state while power supplies ramp up or down slowly.

Overvoltage Protection

Proper power-supply sequencing is recommended for all CMOS devices. Do not exceed the absolute maximum ratings, because stresses beyond the listed ratings can cause permanent damage to the devices. Always sequence V+ on first, then V-, followed by the logic inputs, NO, or COM. If power-supply sequencing

is not possible, add two small-signal diodes (D1, D2) in series with supply pins for overvoltage protection (Figure 1). Adding diodes reduces the analog-signal range to one diode drop below V+ and one diode drop above V-, but does not affect the devices' low switch resistance and low leakage characteristics. Device operation is unchanged, and the difference between V+ and V- should not exceed $17V$. These protection diodes are not recommended when using a single supply.

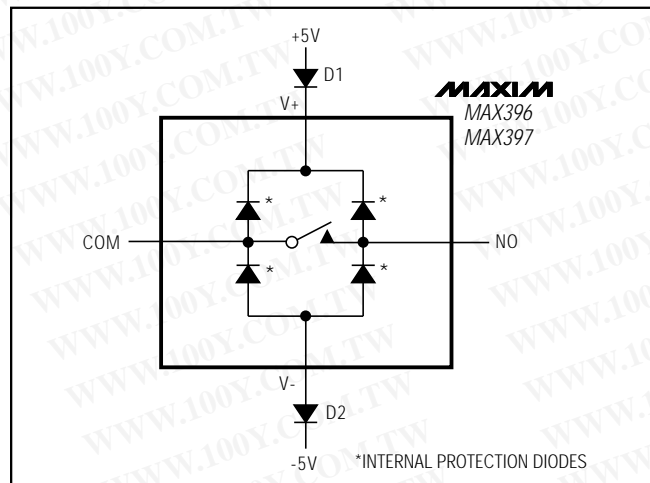

Figure 1. Overvoltage Protection Using External Blocking Diodes

Precision, 16-Channel/Dual 8-Channel, Low-Voltage, CMOS Analog Multiplexers

Test Circuits/Timing Diagrams

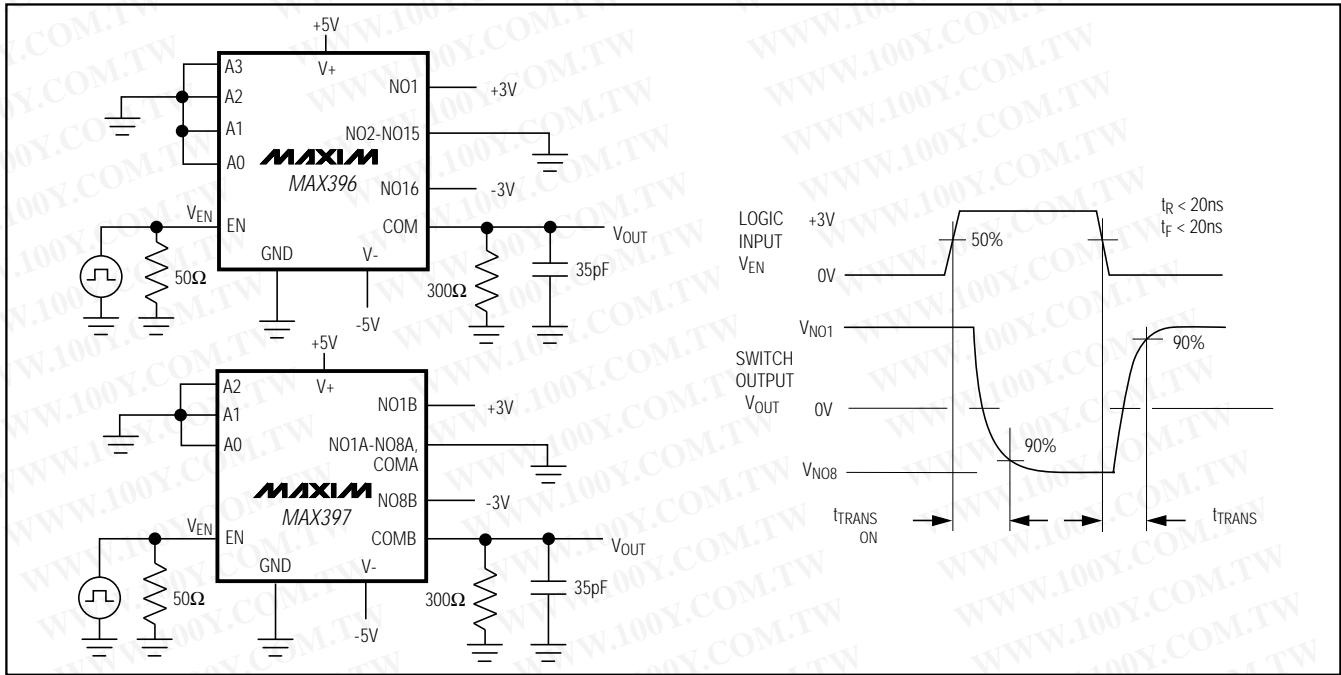

Figure 2. Transition Time

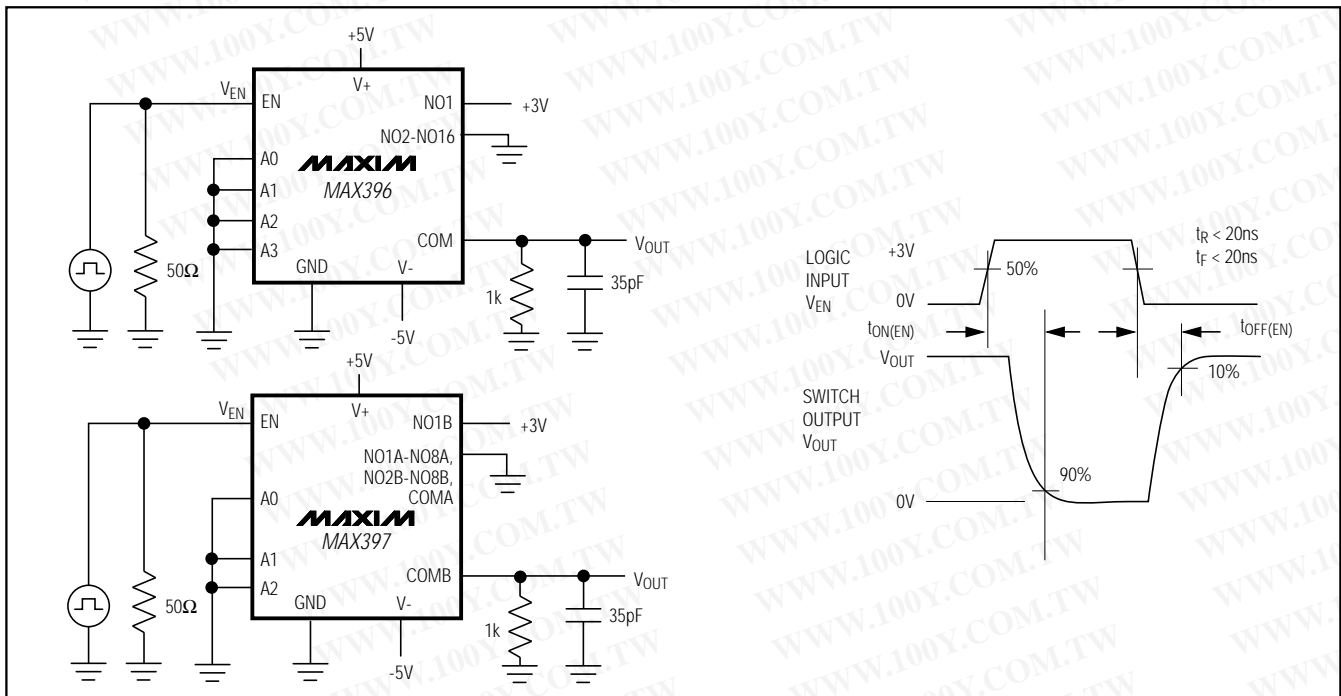

Figure 3. Enable Switching Time

勝特力材料 886-3-5753170
勝特力电子(上海) 86-21-54151736
勝特力电子(深圳) 86-755-83298787
[Http://www.100y.com.tw](http://www.100y.com.tw)

Precision, 16-Channel/Dual 8-Channel, Low-Voltage, CMOS Analog Multiplexers

Test Circuits/Timing Diagrams (continued)

MAX396/MAX397

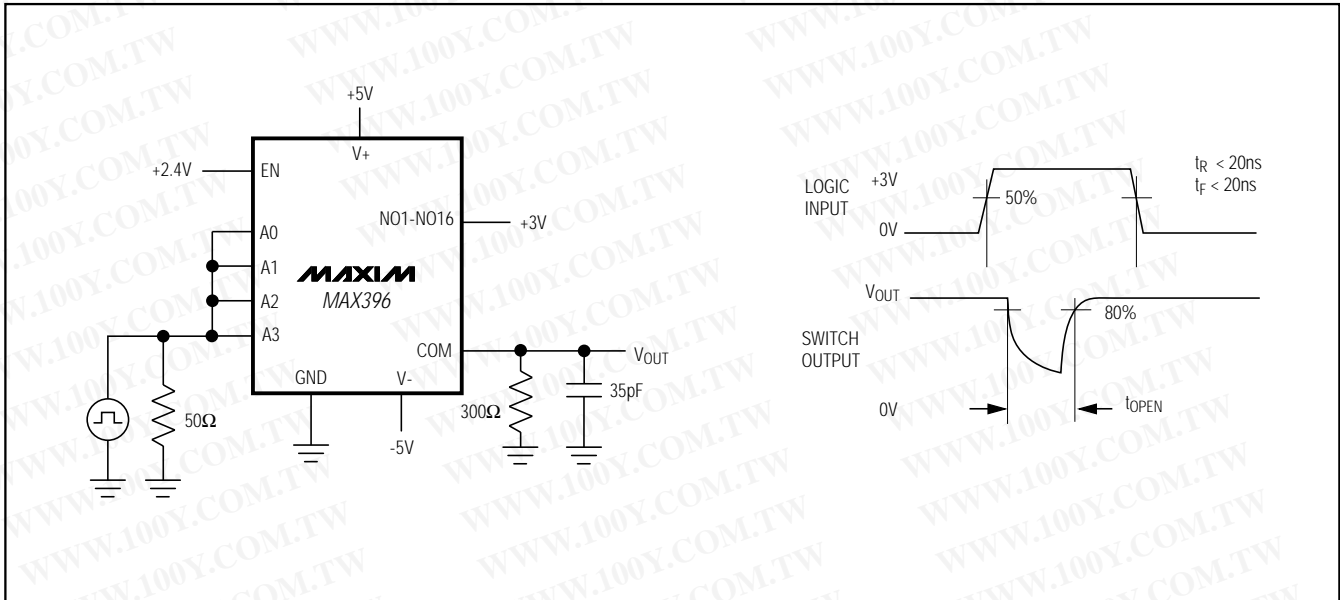

Figure 4. Break-Before-Make Interval

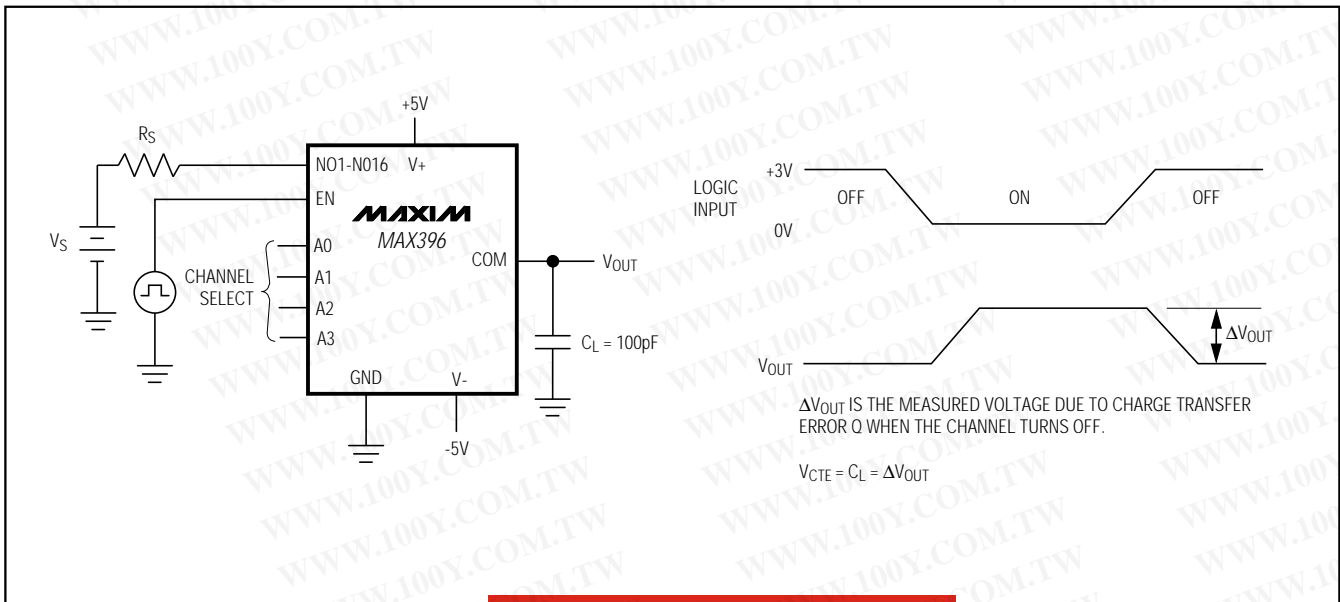

Figure 5. Charge Injection (V_{CTE})

勝特力材料 886-3-5753170
 勝特力电子(上海) 86-21-54151736
 勝特力电子(深圳) 86-755-83298787
[Http://www.100y.com.tw](http://www.100y.com.tw)

Precision, 16-Channel/Dual 8-Channel, Low-Voltage, CMOS Analog Multiplexers

Test Circuits/Timing Diagrams (continued)

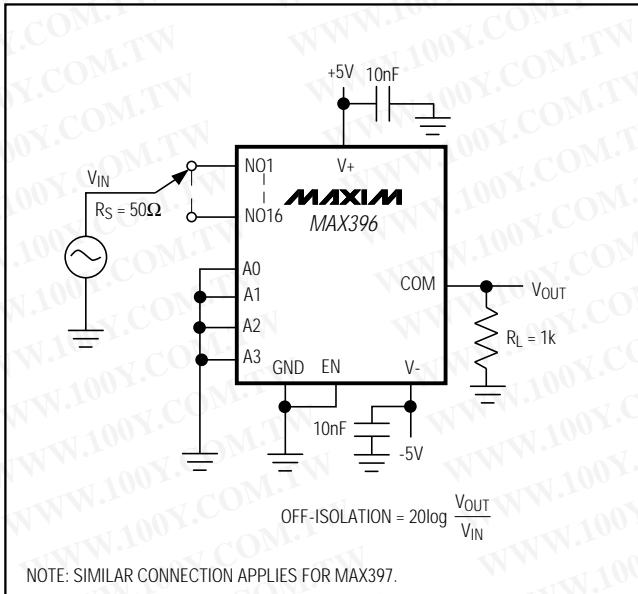

Figure 6. Off-Isolation (V_{ISO})

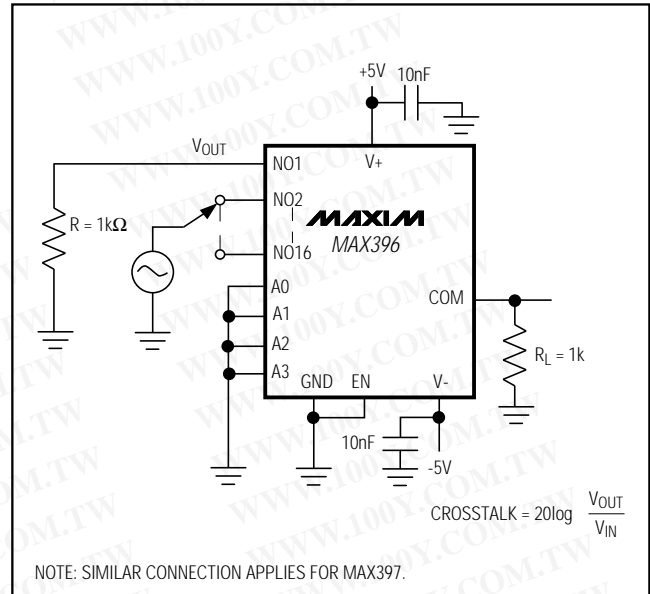

Figure 7. Crosstalk (V_{CT})

Pin Configurations (continued)

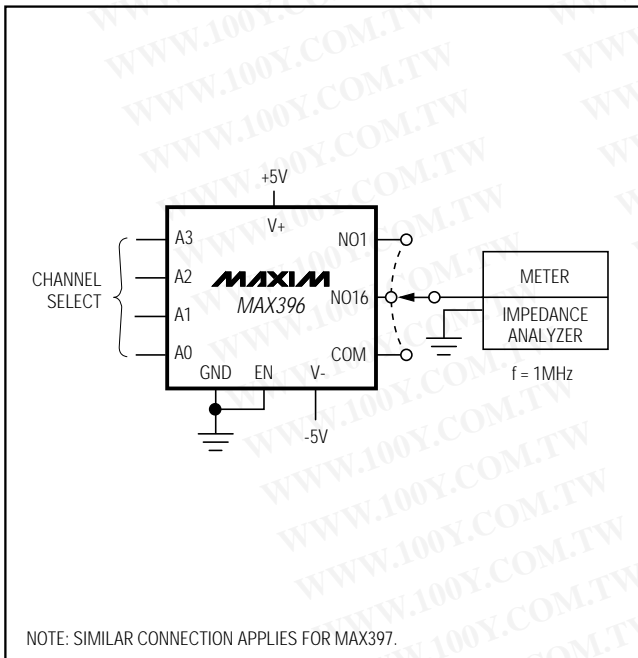
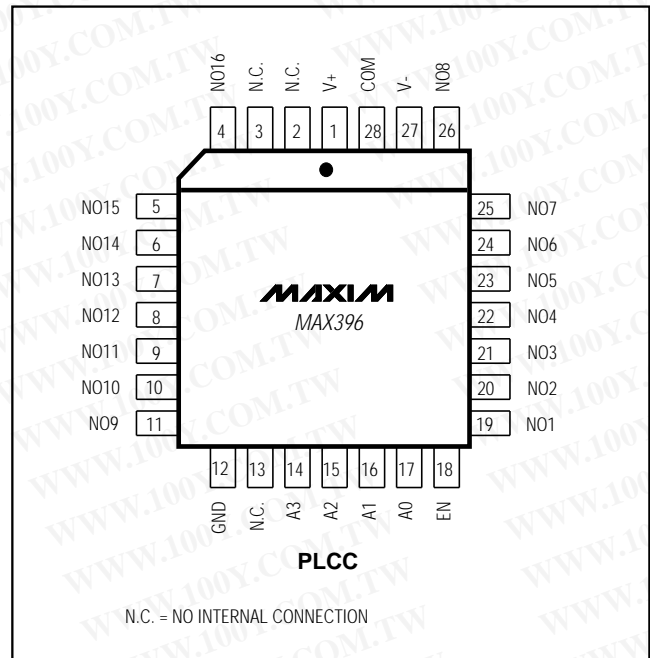

Figure 8. NO/COM Capacitance



勝特力材料 886-3-5753170
 勝特力电子(上海) 86-21-54151736
 勝特力电子(深圳) 86-755-83298787
[Http://www.100y.com.tw](http://www.100y.com.tw)

Precision, 16-Channel/Dual 8-Channel, Low-Voltage, CMOS Analog Multiplexers

Pin Configurations/Functional Diagrams/Truth Tables (continued)

MAX396/MAX397

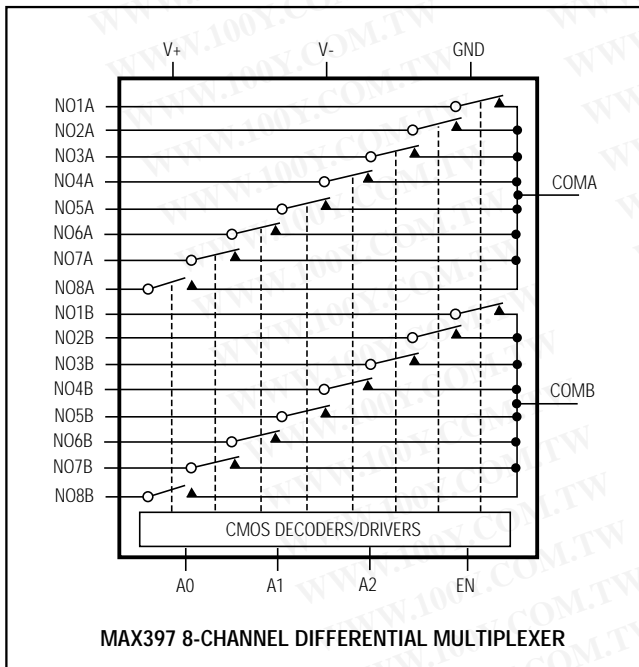
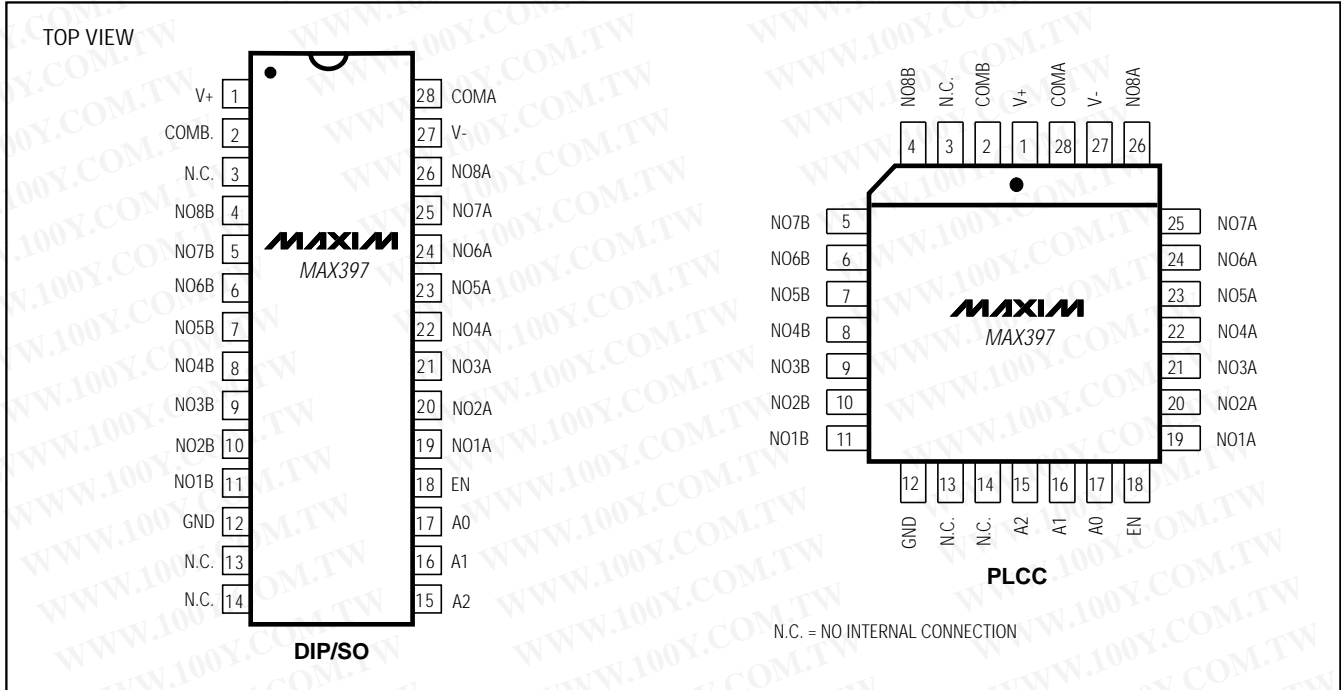

MAX397				
A2	A1	A0	EN	ON SWITCH
X	X	X	0	NONE
0	0	0	1	1
0	0	1	1	2
0	1	0	1	3
0	1	1	1	4
1	0	0	1	5
1	0	1	1	6
1	1	0	1	7
1	1	1	1	8

LOGIC "0" = $V_{AL} \leq 0.8V$, LOGIC "1" = $V_{AH} \geq 2.4V$

Precision, 16-Channel/Dual 8-Channel, Low-Voltage, CMOS Analog Multiplexers

_Ordering Information (continued)

PART	TEMP. RANGE	PIN-PACKAGE
MAX396EPI	-40°C to +85°C	28 Plastic DIP
MAX396EWI	-40°C to +85°C	28 Wide SO
MAX396EQI	-40°C to +85°C	28 PLCC**
MAX396MJI	-55°C to +125°C	28 CERDIP**
MAX397CPI	0°C to +70°C	28 Plastic DIP
MAX397CWI	0°C to +70°C	28 Wide SO
MAX397CAI	0°C to +70°C	28 SSOP
MAX397CQI	0°C to +70°C	28 PLCC**
MAX397C/D	0°C to +70°C	Dice*
MAX397EPI	-40°C to +85°C	28 Plastic DIP
MAX397EWI	-40°C to +85°C	28 Wide SO
MAX397EQI	-40°C to +85°C	28 PLCC**
MAX397MJI	-55°C to +125°C	28 CERDIP**

勝特力材料 886-3-5753170
 勝特力电子(上海) 86-21-54151736
 勝特力电子(深圳) 86-755-83298787
[Http://www.100y.com.tw](http://www.100y.com.tw)

*Contact factory for dice specifications.
 **Contact factory for package availability.

Chip Topographies

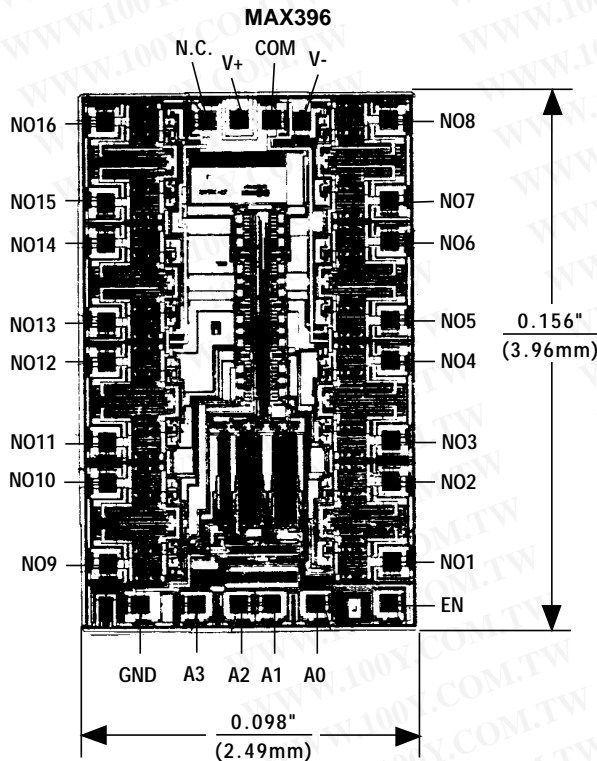

TRANSISTOR COUNT: 360
 SUBSTRATE CONNECTED TO V+

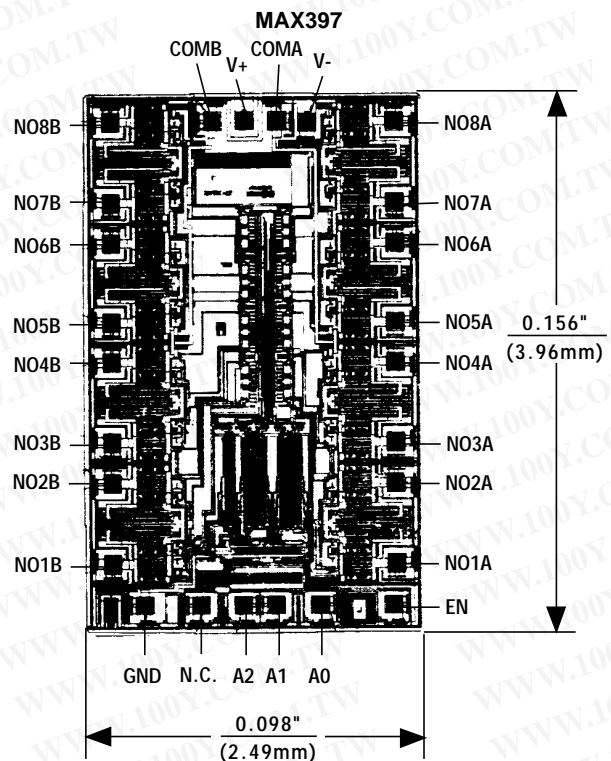

TRANSISTOR COUNT: 360
 SUBSTRATE CONNECTED TO V+

Maxim cannot assume responsibility for use of any circuitry other than circuitry entirely embodied in a Maxim product. No circuit patent licenses are implied. Maxim reserves the right to change the circuitry and specifications without notice at any time.