



Precision, 8-Channel/Dual 4-Channel, High-Performance, CMOS Analog Multiplexers

General Description

The MAX308/MAX309 precision, monolithic, CMOS analog multiplexers (muxes) offer low on-resistance (less than 100Ω), which is matched to within 5Ω between channels and remains flat over the specified analog signal range (7Ω max). They also offer low leakage over temperature (NO-off leakage current less than 5nA at +85°C) and fast switching speeds (transition time less than 250ns). The MAX308 is a single-ended 1-of-8 device, and the MAX309 is a differential 2-of-4 device.

The MAX308/MAX309 are fabricated with Maxim's improved 44V silicon-gate process. Design improvements yield extremely low charge injection (less than 10pC) and guarantee electrostatic discharge protection greater than 2000V.

These muxes operate with a single +4.5V to +30V supply or bipolar ±4.5V to ±20V supplies, while retaining TTL/CMOS-logic input compatibility and fast switching. CMOS inputs provide reduced input loading. These improved parts are plug-in upgrades for the industry-standard DG408, DG409, DG508A, and DG509A.

Applications

- Sample-and-Hold Circuits
- Automatic Test Equipment
- Heads-Up Displays
- Guidance and Control Systems
- Military Radios
- Communications Systems
- Battery-Operated Systems
- PBX, PABX
- Audio Signal Routing

Features

- ♦ **Guaranteed On-Resistance Match Between Channels, <5Ω Max**
- ♦ **Low On-Resistance, <100Ω Max**
- ♦ **Guaranteed Flat On-Resistance over Specified Signal Range, 7Ω Max**
- ♦ **Guaranteed Low Charge Injection, <10pC**
- ♦ **NO-Off Leakage Current <5nA at +85°C**
- ♦ **COM-Off Leakage Current <20nA at +85°C**
- ♦ **ESD Protection >2000V**
- ♦ **Plug-In Upgrade for Industry-Standard DG408/DG409/DG508A/DG509A**
- ♦ **Single-Supply Operation (+4.5V to +30V) Bipolar-Supply Operation (±4.5V to ±20V)**
- ♦ **Low Power Consumption, <300μW**
- ♦ **Rail-to-Rail Signal Handling**
- ♦ **TTL/CMOS-Logic Compatible**

MAX308/MAX309

Ordering Information

PART	TEMP. RANGE	PIN-PACKAGE
MAX308CPE	0°C to +70°C	16 Plastic DIP
MAX308CSE	0°C to +70°C	16 Narrow SO
MAX308C/D	0°C to +70°C	Dice*
MAX308EPE	-40°C to +85°C	16 Plastic DIP
MAX308ESE	-40°C to +85°C	16 Narrow SO
MAX308EJE	-40°C to +85°C	16 CERDIP
MAX308MJE	-55°C to +125°C	16 CERDIP**

Ordering Information continued at end of data sheet.

* Contact factory for dice specifications.

** Contact factory for availability.

Pin Configurations/Functional Diagrams/Truth Tables

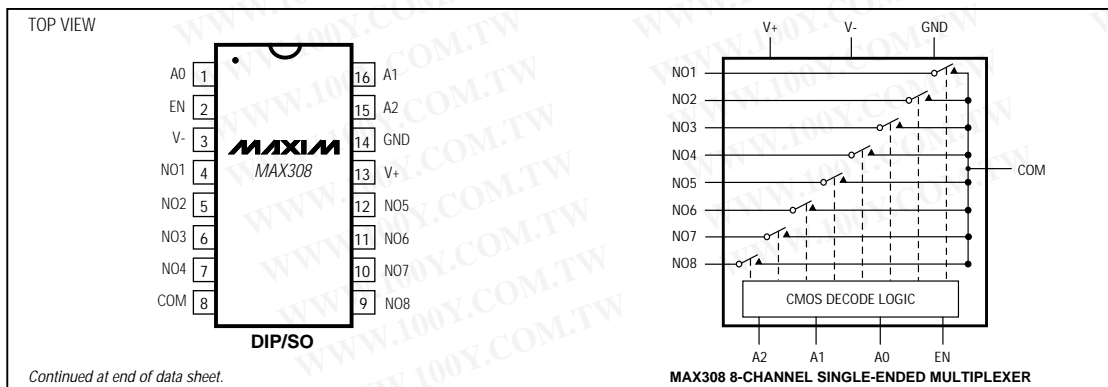

Precision, 8-Channel/Dual 4-Channel, High-Performance, CMOS Analog Multiplexers

MAX308/MAX309

ABSOLUTE MAXIMUM RATINGS

Voltage Referenced to V- V+-0.3V, 44V GND-0.3V, 25V Digital Inputs, NO, COM (Note 1).....(V- - 2V) to (V+ + 2V) or 30mA, (whichever occurs first) Continuous Current (any terminal)30mA Peak Current, NO or COM (pulsed at 1ms, 10% duty cycle max)100mA	Continuous Power Dissipation (TA = +70°C) Plastic DIP (derate 10.53mW/°C above +70°C)842mW Narrow SO (derate 8.70mW/°C above +70°C)696mW CERDIP (derate 10.00mW/°C above +70°C)800mW Operating Temperature Ranges MAX30_C_ _0°C to +70°C MAX30_E_ _-40°C to +85°C MAX30_MJE-55°C to +125°C Storage Temperature Range-65°C to +150°C Lead Temperature (soldering, 10sec)+300°C
---	--

Note 1: Signals on NO, COM, EN, A0, A1, or A2 exceeding V+ or V- are clamped by internal diodes. Limit forward current to maximum current ratings.

Stresses beyond those listed under "Absolute Maximum Ratings" may cause permanent damage to the device. These are stress ratings only, and functional operation of the device at these or any other conditions beyond those indicated in the operational sections of the specifications is not implied. Exposure to absolute maximum rating conditions for extended periods may affect device reliability.

ELECTRICAL CHARACTERISTICS—Dual Supplies

(V+ = +15V, V- = -15V, GND = 0V, VAH = +2.4V, VAL = +0.8V, TA = TMIN to TMAX, unless otherwise noted.)

PARAMETER	SYMBOL	CONDITIONS		MIN	TYP (Note 2)	MAX	UNITS	
SWITCH								
Analog Signal Range	VNO, VCOM	(Note 3)		-15		15	V	
On-Resistance	RON	I _{NO} = -1.0mA, VCOM = ±10V	TA = +25°C		60	100	Ω	
			TA = TMIN to TMAX			125		
On-Resistance Matching Between Channels	ΔRON	I _{NO} = -1.0mA, VCOM = ±10V (Note 4)	TA = +25°C		1.5	5	Ω	
			TA = TMIN to TMAX			8		
On-Resistance Flatness	RFLAT	I _{NO} = -1.0mA, VCOM = ±5V or 0V	TA = +25°C		1.8	7	Ω	
			TA = TMIN to TMAX			10		
NO-Off Leakage Current (Note 5)	I _{NO(OFF)}	VCOM = ∓10V, VNO = ±10V, VEN = 0V	TA = +25°C	-0.5	0.01	0.5	nA	
			TA = TMIN to TMAX	C, E		2.5		
				M		5.0		
COM-Off Leakage Current (Note 5)	I _{COM(OFF)}	VNO = ±10V, VCOM = ∓10V, VEN = 0V	MAX308	TA = +25°C	-0.75	0.02	0.75	nA
				TA = TMIN to TMAX	C, E		-10	
			M		-20	20		
		TA = +25°C		-0.75	0.02	0.75		
		VNO = ∓10V, VCOM = ±10V, VEN = 0V	MAX309	TA = TMIN to TMAX	C, E		-5	5
				M		-10	10	
COM-On Leakage Current (Note 5)	I _{COM(ON)}	VCOM = ±10V, VNO = ±10V, sequence each switch on	MAX308	TA = +25°C	-0.75	0.02	0.75	nA
				TA = TMIN to TMAX	C, E		-10	
			M		-20	20		
		TA = +25°C		-0.75	0.02	0.75		
			MAX309	TA = TMIN to TMAX	C, E		-5	5
				M		-10	10	

Precision, 8-Channel/Dual 4-Channel, High-Performance, CMOS Analog Multiplexers

ELECTRICAL CHARACTERISTICS—Dual Supplies (continued)

(V+ = +15V, V- = -15V, GND = 0V, V_{AH} = +2.4V, V_{AL} = +0.8V, T_A = T_{MIN} to T_{MAX}, unless otherwise noted.)

PARAMETER	SYMBOL	CONDITIONS		MIN	TYP (Note 2)	MAX	UNITS
INPUT							
Input Current with Input Voltage High	I _{AH}	V _A = 2.4V or 15V		-1.0		1.0	μA
Input Current with Input Voltage Low	I _{AL}	V _{EN} = 0V or 2.4V, V _A = 0V		-1.0		1.0	μA
SUPPLY							
Power-Supply Range				±4.5		±20	V
Positive Supply Current	I ₊	V _{EN} = V _A = 0V or 4.5V	T _A = +25°C	16		30	μA
			T _A = T _{MIN} to T _{MAX}			75	
Negative Supply Current	I ₋	V _{EN} = 2.4V, V _{A(ALL)} = 0V or 2.4V	T _A = +25°C	0.075		0.5	mA
			T _A = T _{MIN} to T _{MAX}				
Positive Supply Current	I ₊	V _{EN} = 2.4V, V _{A(ALL)} = 0V or 2.4V	T _A = +25°C	-1		1	μA
			T _A = T _{MIN} to T _{MAX}	-10		10	
DYNAMIC							
Transistion Time	t _{TRANS}	Figure 2	T _A = +25°C	85		175	ns
			T _A = T _{MIN} to T _{MAX}			250	
Break-Before-Make Interval	t _{OPEN}	Figure 4	T _A = +25°C	10		40	ns
Enable Turn-On Time	t _{ON(EN)}	Figure 3	T _A = +25°C	85		150	ns
			T _A = T _{MIN} to T _{MAX}			225	
Enable Turn-Off Time	t _{OFF(EN)}	Figure 3	T _A = +25°C			150	ns
Charge Injection (Note 3)	Q	C _L = 1.0nF, V _{NO} = 0V, R _S = 0Ω, Figure 5	T _A = T _{MIN} to T _{MAX}			300	pC
			T _A = +25°C	2		10	
Off Isolation (Note 6)	V _{ISO}	V _{EN} = 0V, R _L = 1kΩ, f = 100kHz, Figure 6	T _A = +25°C			-75	dB
Crosstalk Between Channels	V _{CT}	V _{EN} = 2.4V, f = 100kHz, V _{GEN} = 1V _{P-P} , R _L = 1kΩ, Figure 7	T _A = +25°C			-92	dB
Logic Input Capacitance	C _{IN}	f = 1MHz	T _A = +25°C			8	pF
NO-Off Capacitance	C _{NO(OFF)}	f = 1MHz, V _{EN} = V _{NO} = 0V, Figure 8	T _A = +25°C			3	pF
COM-Off Capacitance	C _{COM(OFF)}	f = 1MHz, V _{EN} = 0.8V V _{COM} = 0V, Figure 8	MAX308	T _A = +25°C		26	pF
			MAX309			14	
COM-On Capacitance	C _{COM(ON)}	f = 1MHz, V _{EN} = 2.4V V _{COM} = 0V, Figure 8	MAX308	T _A = +25°C		37	pF
			MAX309			25	

MAX308/MAX309

Precision, 8-Channel/Dual 4-Channel, High-Performance, CMOS Analog Multiplexers

ELECTRICAL CHARACTERISTICS—Single Supply

(V+ = +12V, V- = 0V, GND = 0V, V_{AH} = +2.4V, V_{AL} = +0.8V, T_A = T_{MIN} to T_{MAX}, unless otherwise noted.)

PARAMETER	SYMBOL	CONDITIONS		MIN	TYP (Note 2)	MAX	UNITS
SWITCH							
Analog Signal Range	V _{NO} , V _{COM}	(Note 3)		0		12	V
On-Resistance	R _{ON}	I _{NO} = -1.0mA V _{COM} = 3V or 10V	T _A = +25°C		120	175	Ω
DYNAMIC							
Transition Time (Note 3)	t _{TRANS}	V _{NO1} = 8V, V _{NO8} = 0V, V _{IN} = 2.4V, Figure 2	T _A = +25°C		115	450	ns
Enable Turn-On Time (Note 3)	t _{ON(EN)}	V _{INH} = 2.4V, V _{INL} = 0V, V _{NO1} = 5V, Figure 3	T _A = +25°C		100	600	ns
Enable Turn-Off Time (Note 3)	t _{OFF(EN)}	V _{INH} = 2.4V, V _{INL} = 0V, V _{NO1} = 5V, Figure 3	T _A = +25°C		75	300	ns
Charge Injection (Note 3)	Q	C _L = 1.0nF, V _{NO} = 0V, R _S = 0Ω	T _A = +25°C		2	10	pC

Note 2: The algebraic convention where the most negative value is a minimum and the most positive value a maximum is used in this data sheet.

Note 3: Guaranteed by design.

Note 4: $\Delta R_{ON} = R_{ON(MAX)} - R_{ON(MIN)}$. On-resistance match between channels and flatness are guaranteed only with specified voltages. Flatness is defined as the difference between the maximum and minimum value of on-resistance as measured at the extremes of the specified analog signal range.

Note 5: Leakage parameters are 100% tested at the maximum rated hot temperature and guaranteed by correlation at +25°C.

Note 6: Off isolation = $20 \log V_{COM}/V_{NO}$, where V_{COM} = output and V_{NO} = input to off switch.

Precision, 8-Channel/Dual 4-Channel, High-Performance, CMOS Analog Multiplexers

Typical Operating Characteristics

(T_A = +25°C, unless otherwise noted.)

MAX308/MAX309

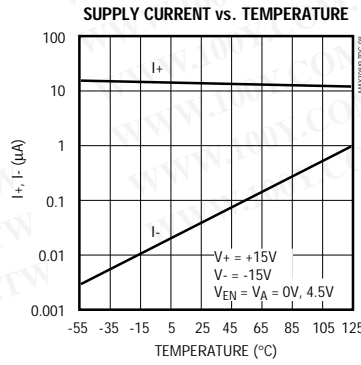
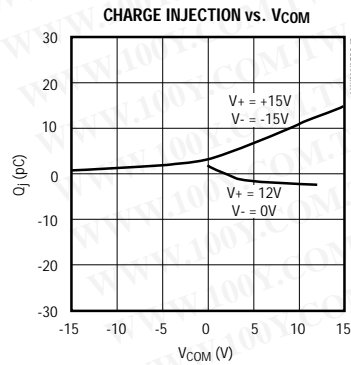
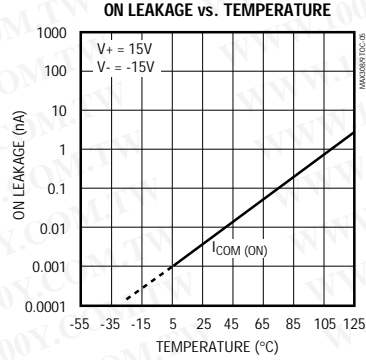
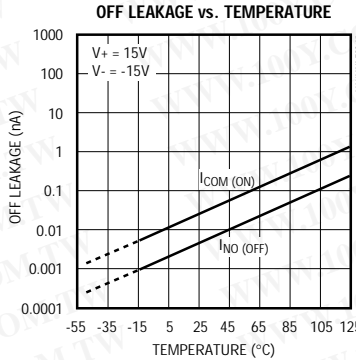
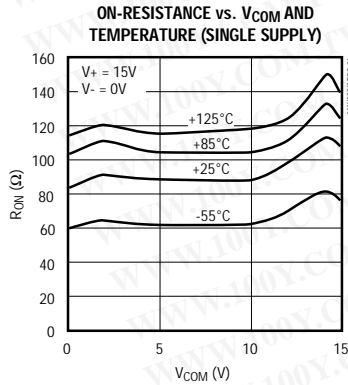
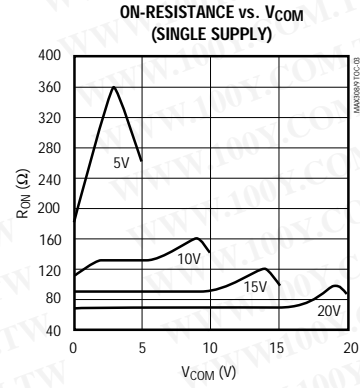
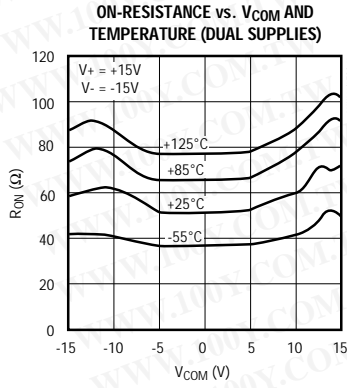
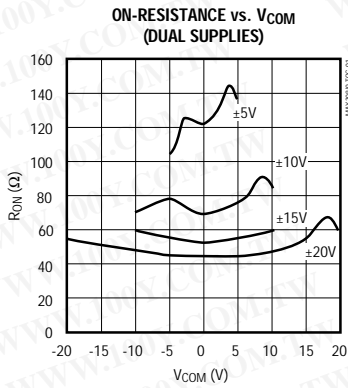

Precision, 8-Channel/Dual 4-Channel, High-Performance, CMOS Analog Multiplexers

Pin Description

PIN		NAME	FUNCTION
MAX308	MAX309		
1, 15, 16	—	A0, A2, A1	Address Inputs
—	1, 16	A0, A1	Address Inputs
2	2	EN	Enable Input
3	3	V-	Negative Supply Voltage Input
4-7	—	NO1-NO4	Analog Inputs—bidirectional
—	4-7	NO1A-NO4A	Analog Inputs—bidirectional
8	—	COM	Analog Output—bidirectional
—	8, 9	COMA, COMB	Analog Outputs—bidirectional
9-12	—	NO8-NO5	Analog Inputs—bidirectional
—	10-13	NO4B-NO1B	Analog Inputs—bidirectional
13	14	V+	Positive Supply Voltage Input
14	15	GND	Ground

Applications Information

Operation with Supply Voltages Other than 15V

Using supply voltages less than $\pm 15V$ will reduce the analog signal range. The MAX308/MAX309 switches operate with $\pm 4.5V$ to $\pm 20V$ bipolar supplies or with a $+4.5V$ to $+30V$ single supply. Connect V- to GND when operating with a single supply. Both device types can also operate with unbalanced supplies, such as $+24V$ and $-5V$. The *Typical Operating Characteristics* graphs show typical on-resistance with 20V, 15V, 10V, and 5V supplies. (Switching times increase by a factor of two or more for operation at 5V.)

Overvoltage Protection

Proper power-supply sequencing is recommended for all CMOS devices. Do not exceed the absolute maximum ratings, because stresses beyond the listed ratings may cause permanent damage to the devices. Always sequence V+ on first, then V-, followed by the logic inputs, NO, or COM. If power-supply sequencing is not possible, add two small signal diodes in series with supply pins for overvoltage protection (Figure 1). Adding diodes reduces the analog signal range to 1V below V+ and 1V above V-, but does not affect the devices' low switch resistance and low leakage characteristics. Device operation is unchanged, and the difference between V+ and V- should not exceed +44V.

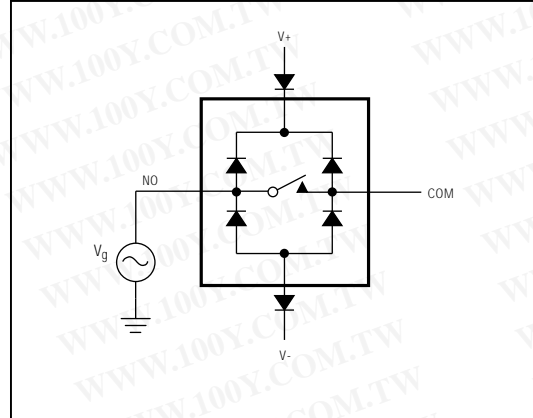

Figure 1. Overvoltage Protection Using External Blocking Diodes

Precision, 8-Channel/Dual 4-Channel, High-Performance, CMOS Analog Multiplexers

Test Circuits/Timing Diagrams

MAX308/MAX309

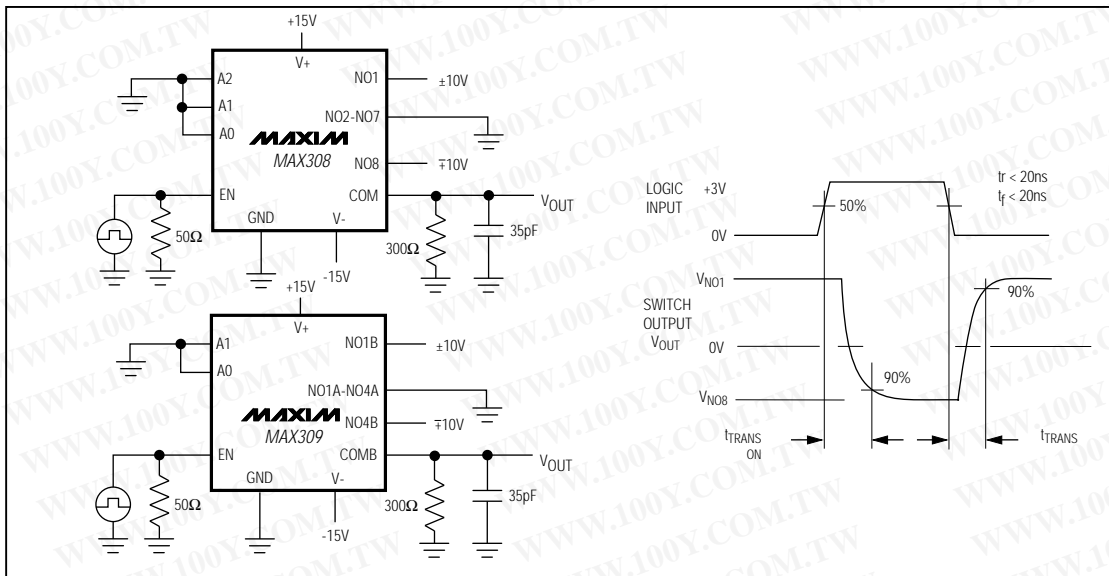

Figure 2. Transition Time

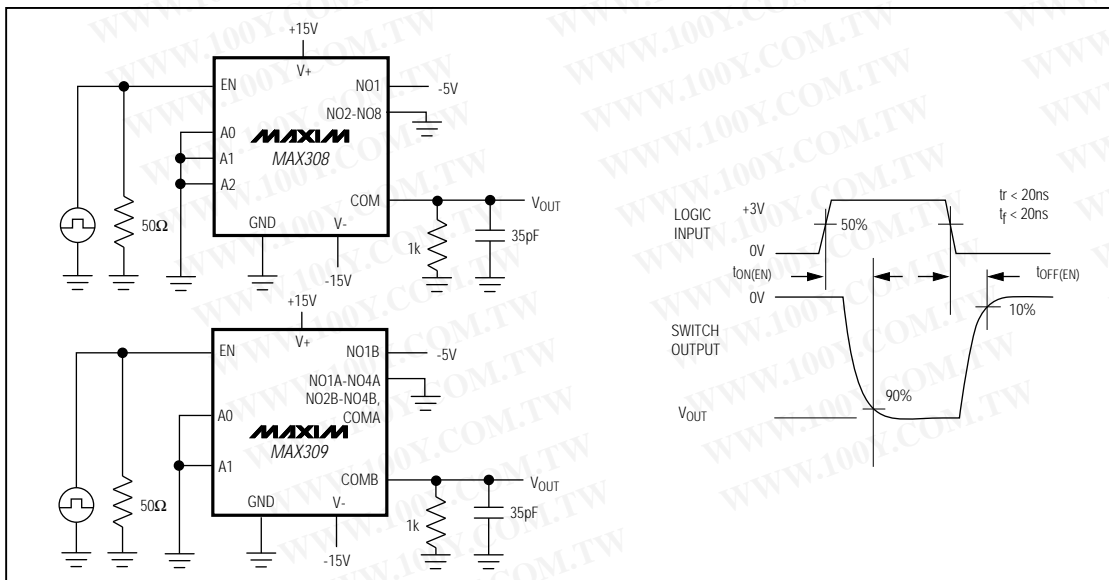

Figure 3. Enable Switching Time

Precision, 8-Channel/Dual 4-Channel, High-Performance, CMOS Analog Multiplexers

Test Circuits/Timing Diagrams (continued)

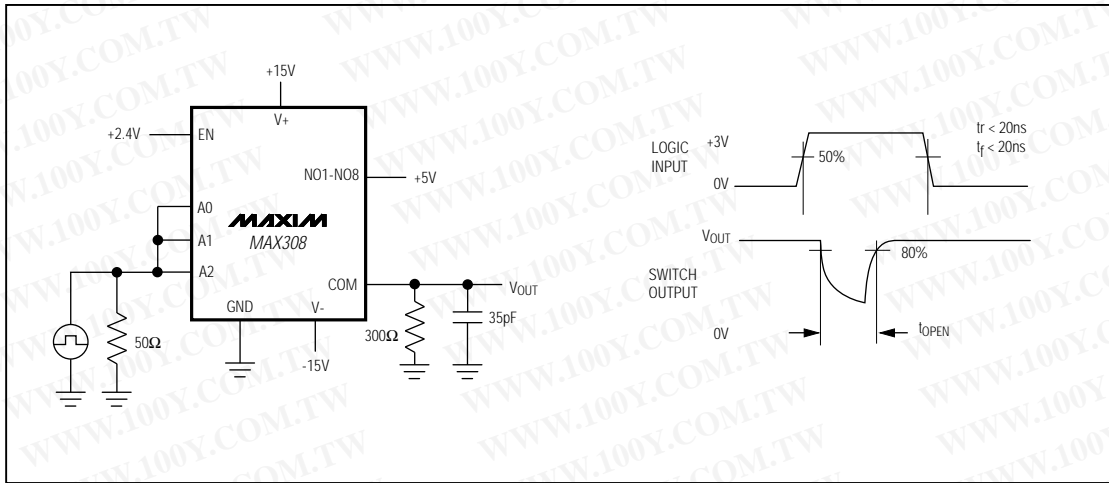

Figure 4. Break-Before-Make Interval

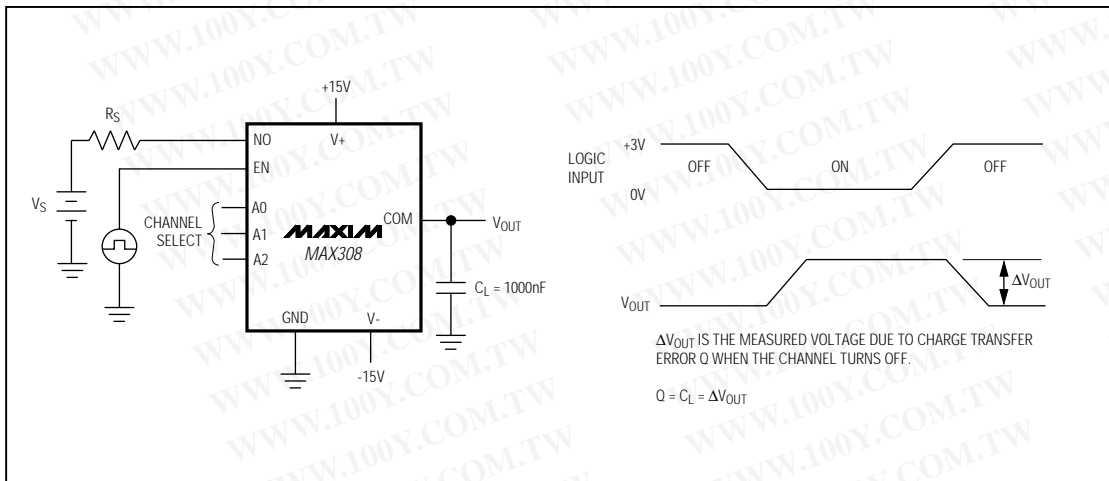

Figure 5. Charge Injection

Precision, 8-Channel/Dual 4-Channel, High-Performance, CMOS Analog Multiplexers

Test Circuits/Timing Diagrams (continued)

MAX308/MAX309

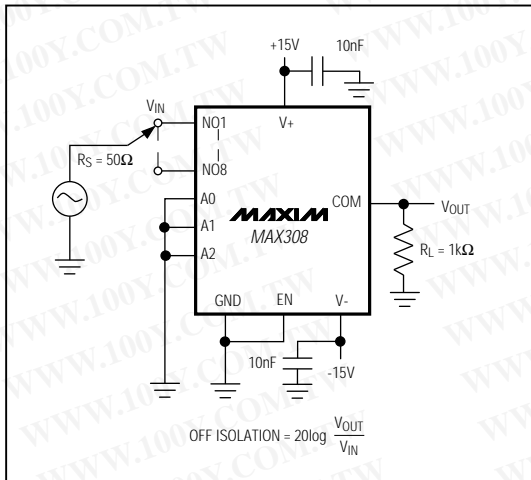

Figure 6. Off Isolation

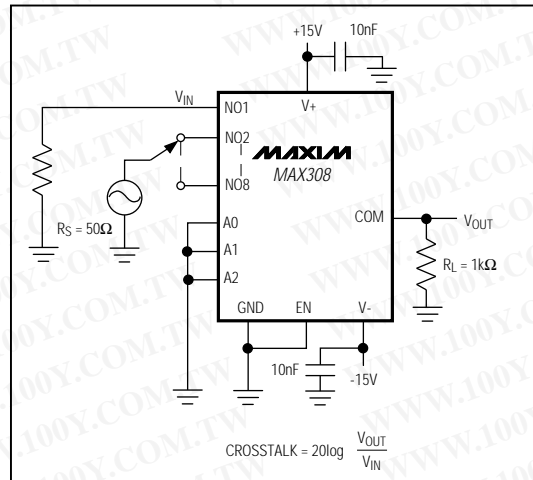

Figure 7. Crosstalk

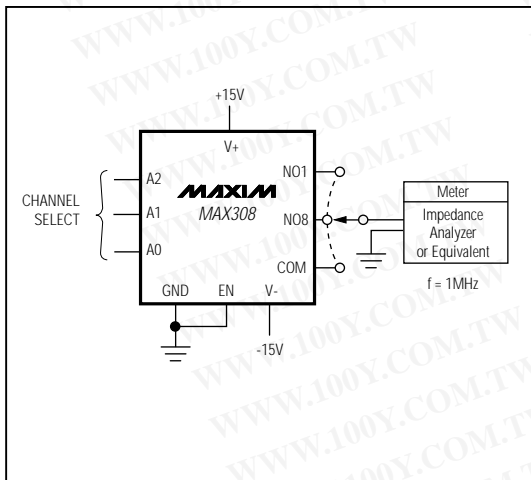
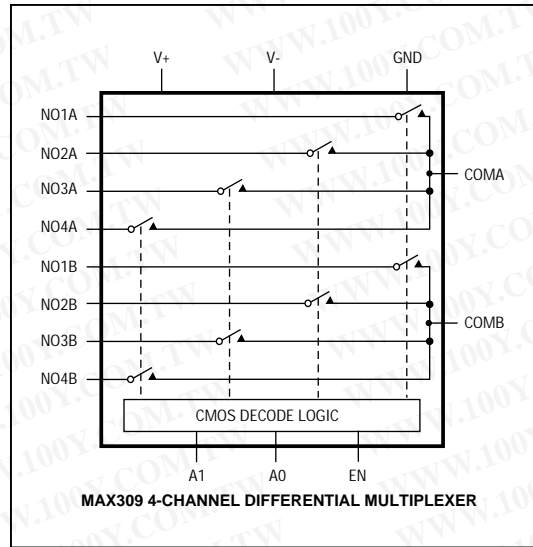
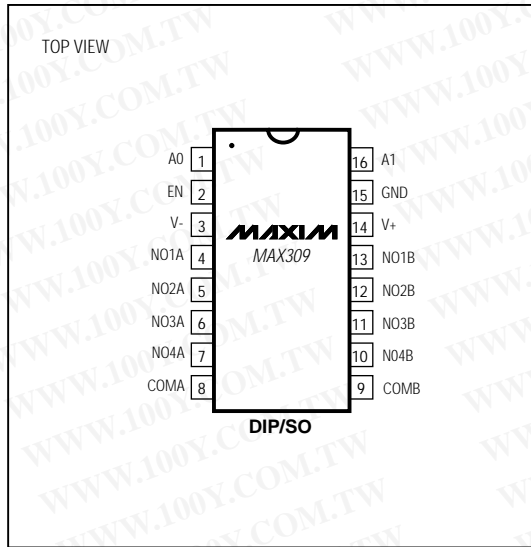

Figure 8. NO/COM Capacitance

Precision, 8-Channel/Dual 4-Channel, High-Performance, CMOS Analog Multiplexers

MAX308/MAX309

Pin Configurations/Functional Diagrams/Truth Tables (continued)



A2	A1	A0	EN	ON SWITCH
X	X	X	0	None
0	0	0	1	1
0	0	1	1	2
0	1	0	1	3
0	1	1	1	4
1	0	0	1	5
1	0	1	1	6
1	1	0	1	7
1	1	1	1	8

MAX308

LOGIC "0" $V_{AL} \leq 0.8V$, LOGIC "1" $V_{AH} \geq 2.4V$

A1	A0	EN	ON SWITCH
X	X	0	None
0	0	1	1
0	1	1	2
1	0	1	3
1	1	1	4

MAX309

LOGIC "0" $V_{AL} \leq 0.8V$, LOGIC "1" $V_{AH} \geq 2.4V$

勝特力材料 886-3-5753170
勝特力电子(上海) 86-21-54151736
勝特力电子(深圳) 86-755-83298787
[Http://www.100y.com.tw](http://www.100y.com.tw)

Precision, 8-Channel/Dual 4-Channel, High-Performance, CMOS Analog Multiplexers

_Ordering Information (continued)

PART	TEMP. RANGE	PIN-PACKAGE
MAX309CPE	0°C to +70°C	16 Plastic DIP
MAX309CSE	0°C to +70°C	16 Narrow SO
MAX309C/D	0°C to +70°C	Dice*
MAX309EPE	-40°C to +85°C	16 Plastic DIP
MAX309ESE	-40°C to +85°C	16 Narrow SO
MAX309EJE	-40°C to +85°C	16 CERDIP
MAX309MJE	-55°C to +125°C	16 CERDIP**

* Contact factory for dice specifications.

** Contact factory for availability.

MAX308/MAX309

Precision, 8-Channel/Dual 4-Channel, High-Performance, CMOS Analog Multiplexers

Chip Topographies

MAX308/MAX309

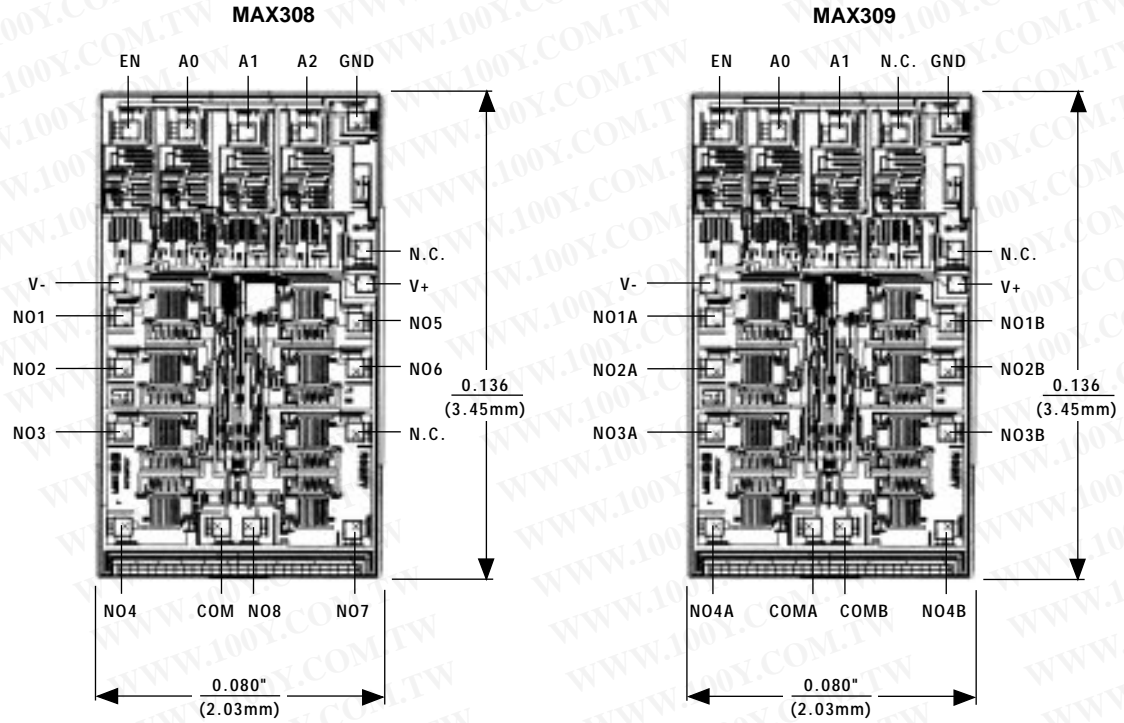

N.C. = NO INTERNAL CONNECTION

TRANSISTOR COUNT: 122
 SUBSTRATE CONNECTED TO V+

TRANSISTOR COUNT: 122
 SUBSTRATE CONNECTED TO V+

Maxim cannot assume responsibility for use of any circuitry other than circuitry entirely embodied in a Maxim product. No circuit patent licenses are implied. Maxim reserves the right to change the circuitry and specifications without notice at any time.

12 Maxim Integrated Products, 120 San Gabriel Drive, Sunnyvale, CA 94086 (408) 737-7600

© 1994 Maxim Integrated Products

Printed USA

MAXIM is a registered trademark of Maxim Integrated Products.