

LMC-	STC SSC	2B16	16 CHARS × 2 LINES	1/16 DUTY	1/4 BIAS
------	------------	------	--------------------	-----------	----------

勝特力材料 886-3-5753170
 勝特力电子(上海) 86-21-54151736
 勝特力电子(深圳) 86-755-83298787
[Http://www.100y.com.tw](http://www.100y.com.tw)

1.FEATURE:

LCD MODE	TN/STN
BACKLIGHT TYPE	LED/EL BACKLIGHT
CHARACTER FONTS	5×8 DOTS (WITH CURSOR)
CONTROLLER	NT3881 OR EQUIVALENT
POWER SUPPLY FOR LCM	DC +5V
LED BACKLIGHT INPUT	DC +5V
EL BACKLIGHT INPUT	AC90~100V(400~700Hz)
EL INVERTER	SDEC-I001A(I001B)

2.ELECTRICAL CHARACTERISTICS:

ITEM	SYM	CONDITION	MIN	TYP	MAX	UNIT
SUPPLY VOLTAGE FOR LCD	VDD-VO	Ta=0°C	-	4.6	-	V
		Ta=25°C	-	4.4	-	V
		Ta=50°C	-	4.2	-	V
INPUT VOLTAGE	VI	-	4.5	5.0	5.5	V
INPUT HIGH VOL	VIH	-	2.2	-	VDD	V
INPUT LOW VOL	VIL	-	0	-	0.6	V
OUTPUT HIGH VOL	VOH	-	2.4	-	-	V
OUTPUT LOW VOL	VOL	-	-	-	0.4	V
SUPPLY CURRENT	IDD	VDD=5v	-	3.0	4.5	mA
LED CURRENT	IF	Ta=25°C	-	100	-	mA
LED DISSIPATION	PD	Ta=25°C	-	500	-	mW

3.ABSOLUTE MAXIMUM RATINGS:

ITEM	SYMBOL	MIN	TYP	MAX	UNIT
OPERATING TEMP	TOP	0	-	50	°C
STORAGE TEMP.	TST	-10	-	60	°C
INPUT VOLTAGE	VI	VSS	-	VDD	V
SUPPLY VOL-LOGIC	VDD-VSS	-	5.0	6.5	V
SUPPLY VOL-LCD	VDD-VO	-	-	6.5	V

4.BLOCK DIAGRAM:

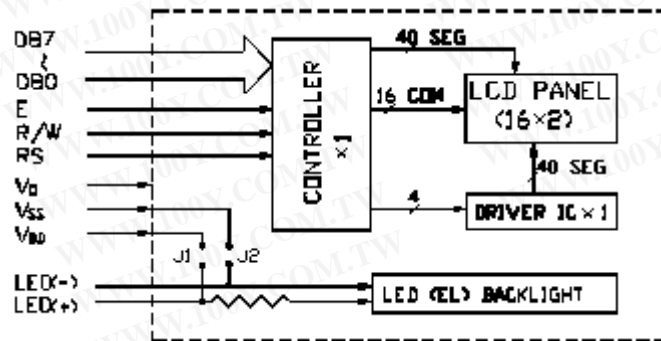

5.INTERFACE PIN CONNECTIONS:

NO	SYM	LEVEL	FUNCTION	NO	SYM	LEVEL	FUNCTION
1	VSS	-	0V	9	DB2	H/L	DATA BIT2
2	VDD	-	5V	10	DB3	H/L	DATA BIT3
3	VO	-	CONTRAST ADJ	11	DB4	H/L	DATA BIT4
4	RS	H/L	REGISTER	12	DB5	H/L	DATA BIT5

			SELECT			
5	R/W	H/L	READ/WRITE	13	DB6	H/L DATA BIT6
6	E	H.H->L	ENABLE SIGNAL	14	DB7	H/L DATA BIT7
7	DB0	H/L	DATA BIT0	15	A(+)	5V BACKLIGHT
8	DB1	H/L	DATA BIT1	16	K(-)	0V BACKLIGHT

6.DISPLAY CHARACTER ADDRESS CODE:

	1	2	3	4	5	6	7	8	9	10	11	12	13	14	15	16
L1	80	81	82	83	84	85	86	87	88	89	8A	8B	8C	8D	8E	8F
L2	C0	C1	C2	C3	C4	C5	C6	C7	C8	C9	CA	CB	CC	CD	CE	CF

7.DIMENSIONAL DRAWING:

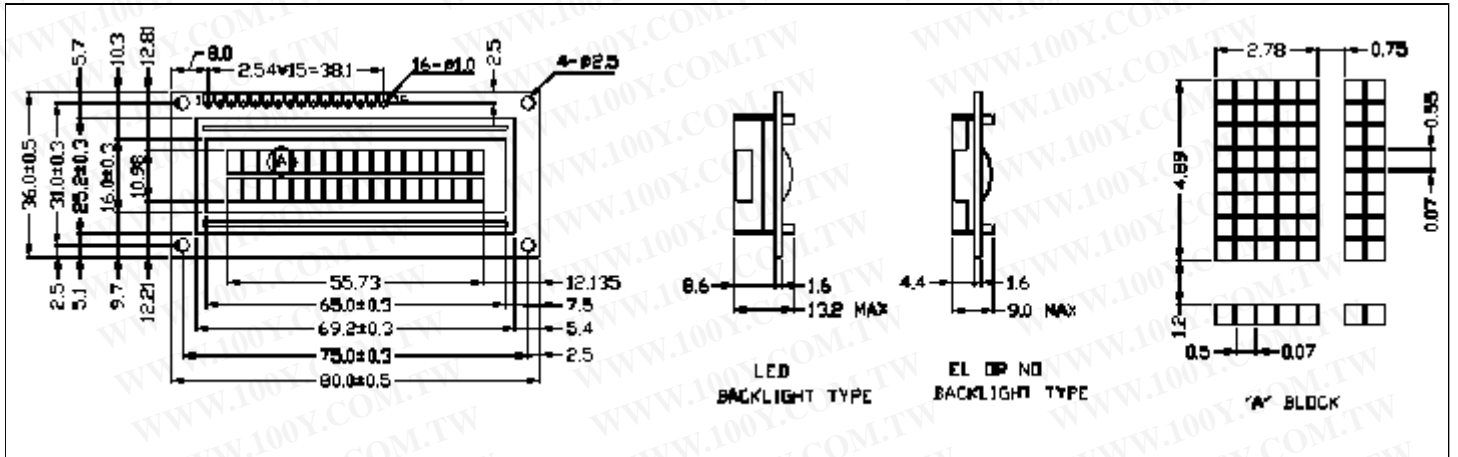

勝特力材料 886-3-5753170
 勝特力电子(上海) 86-21-54151736
 勝特力电子(深圳) 86-755-83298787
[Http://www.100y.com.tw](http://www.100y.com.tw)