

GENERAL DESCRIPTION

This Series of fixed-voltage monolithic integrated circuit voltage regulators is designed for a wide range of applications. These applications include on-card regulation for elimination of noise and distribution problems associated with single-point regulation. In addition, they can be used with power-pass elements to make high-current voltage regulators. One of these regulators can deliver up to 100 mA of output current. The internal limiting and thermal shutdown features of these regulators make them essentially immune to overload. When used as a replacement for a zener diode-resistor combination, an effective improvement in output impedance can be obtained together with lower-bias current.

FEATURES

- 3-terminal regulators
- Output current up to 100 mA
- No external component
- Internal thermal overload protection
- Internal short-circuit current limiting
- Direct replacements for LM78L00, μ A78L00 and AN78L00 series

APPLICATIONS

- Linear regulator
- Instrumentation
- Switching power supplies
- PCs, Industrial equipment

勝特力材料 886-3-5753170
 勝特力电子(上海) 86-21-54151736
 勝特力电子(深圳) 86-755-83298787
[Http://www.100y.com.tw](http://www.100y.com.tw)

PIN CONFIGURATIONS

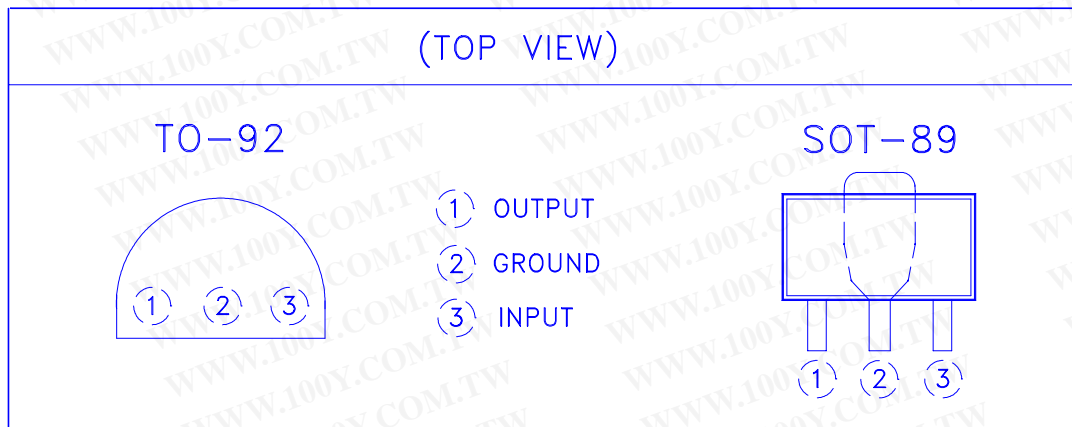

DEVICE SELECTION GUIDE

Device	L78L05N	L78L05C	L78L12N	L78L12C
Package	TO-92	SOT-89	TO-92	SOT-89
Marking	78L05	78L05	78L12	78L12

勝特力材料 886-3-5753170
 勝特力电子(上海) 86-21-54151736
 勝特力电子(深圳) 86-755-83298787
[Http://www.100y.com.tw](http://www.100y.com.tw)

ABSOLUTE MAXIMUM RATINGS

PARAMETER	VALUE
Input Voltage - V_I	30V
Continuous total power dissipation	(See Note 1)
Storage Temperature Range - T_{STG}	-65 to +150 °C
Junction Temperature - T_J	125 °C
Lead Temperature (Soldering, 10 Seconds) - T_L	260 °C

Note1: To avoid exceeding the design maximum virtual junction temperature, three ratings should not be exceeded. Due to variations in individual device electrical characteristics and thermal resistance, the built-in thermal overload protection may be activated at power levels slightly above or below the rated dissipation.

DISSIPATION RATING TABLE 1 – FREE-AIR TEMPERATURE

PACKAGE	$T_A \leq 25^\circ\text{C}$ POWER RATING	DERATING FACTOR	DERATING ABOVE T_A	$T_A = 70^\circ\text{C}$ POWER RATING
TO-92	650 mW	6.2 mW/°C	25 °C	350 mW
SOT-89	500 mW	4.0 mW/°C	25 °C	300 mW

† The TO-92 package dissipation rating is based on thermal resistance θ_{JA} measured in still air with the device mounted in an Augat socket. The bottom of the package is 10mm (0.375 in) above the stock.

DISSIPATION RATING TABLE 2 – CASE TEMPERATURE

PACKAGE	$T_A \leq 25^\circ\text{C}$ POWER RATING	DERATING FACTOR	DERATING ABOVE T_C	$T_C = 125^\circ\text{C}$ POWER RATING
TO-92	1600 mW	28.6 mW/°C	94 °C	713 mW
SOT-89	3125 mW	25.0 mW/°C		

RECOMMENDED OPERATING CONDITIONS

PARAMETER	VALUE
Input Voltage - V_I L78L05 L78L12	7V to 20V 14.5V to 27V
Output Current - I_{OUT}	100 mA (Max)
Operating Virtual Junction Temperature - T_J	0 to 125 °C

ELECTRICAL SPECIFICATIONS (L78L05)(V_I = 10V, I_O = 40 mA, C_I = 0.33 μF, C_O = 0.1 μF, 0 °C < T_J < +125 °C unless otherwise noted.)

PARAMETER	TEST CONDITIONS	MIN	TYP	MAX	UNITS
Output Voltage	T _J = +25 °C	4.8	5.0	5.2	V
Line Regulation	T _J = +25 °C, I _O = 40 mA 7.0V ≤ V _I ≤ 20V 8.0V ≤ V _I ≤ 20V		55 45	150 100	mV
Load Regulation	T _J = +25 °C 1.0 mA ≤ I _O ≤ 100 mA 1.0 mA ≤ I _O ≤ 40 mA		11 5.0	60 30	mV
Output Voltage	7.0V ≤ V _I ≤ 20V, 1.0 mA ≤ I _O ≤ 40 mA V _I = 10V, 1.0 mA ≤ I _O ≤ 70 mA	4.75 4.75		5.25 5.25	V
Input Bias Current	T _J = +25 °C T _J = +125 °C		3.8	6.0 5.5	mA
Input Bias Current Change	8.0V ≤ V _I ≤ 20V 1.0 mA ≤ I _O ≤ 40 mA			1.5 0.1	mA
Output Noise Voltage	T _A = +25 °C, 10 Hz ≤ f ≤ 100 KHz		40		μV
Ripple Rejection	T _J = +25 °C, I _O = 40 mA, f = 120 Hz 8.0V ≤ V _I ≤ 18V	41	49		nA
Dropout Voltage	T _J = +25 °C		1.7		V

ELECTRICAL SPECIFICATIONS (L78L12)(V_I = 19V, I_O = 40 mA, C_I = 0.33 μF, C_O = 0.1 μF, 0 °C < T_J < +125 °C unless otherwise noted.)

PARAMETER	TEST CONDITIONS	MIN	TYP	MAX	UNITS
Output Voltage	T _J = +25 °C	11.5	12.0	12.5	V
Line Regulation	T _J = +25 °C, I _O = 40 mA 14.5V ≤ V _I ≤ 27V 16V ≤ V _I ≤ 27V		120 100	250 200	mV
Load Regulation	T _J = +25 °C 1.0 mA ≤ I _O ≤ 100 mA 1.0 mA ≤ I _O ≤ 40 mA		20 10	100 50	mV
Output Voltage	14.5V ≤ V _I ≤ 27V, 1.0 mA ≤ I _O ≤ 40 mA V _I = 19V, 1.0 mA ≤ I _O ≤ 70 mA	11.4 11.4		12.6 12.6	V
Input Bias Current	T _J = +25 °C T _J = +125 °C		4.2	6.5 6.0	mA
Input Bias Current Change	16V ≤ V _I ≤ 27V 1.0 mA ≤ I _O ≤ 40 mA			1.5 0.1	mA
Output Noise Voltage	T _A = +25 °C, 10 Hz ≤ f ≤ 100 KHz		80		μV
Ripple Rejection	T _J = +25 °C, I _O = 40 mA, f = 120 Hz 15V ≤ V _I ≤ 25V	37	42		nA
Dropout Voltage	T _J = +25 °C		1.7		V

TO-92 MECHANICAL DATA

Dimension	mm			Dimension	mm		
	Min.	Typ.	Max.		Min.	Typ.	Max.
A	4.445		5.207	H	2.413	2.540	2.667
B	4.318		5.334	I	0.356		0.533
C	12.7		15.5	J			
D	0.356		0.533	K			
E	1.143	1.27	1.397	L			
F	3.175		4.191	M			
G	0.762		1.270	N			

勝特力材料 886-3-5753170
 勝特力电子(上海) 86-21-54151736
 勝特力电子(深圳) 86-755-83298787
[Http://www.100y.com.tw](http://www.100y.com.tw)

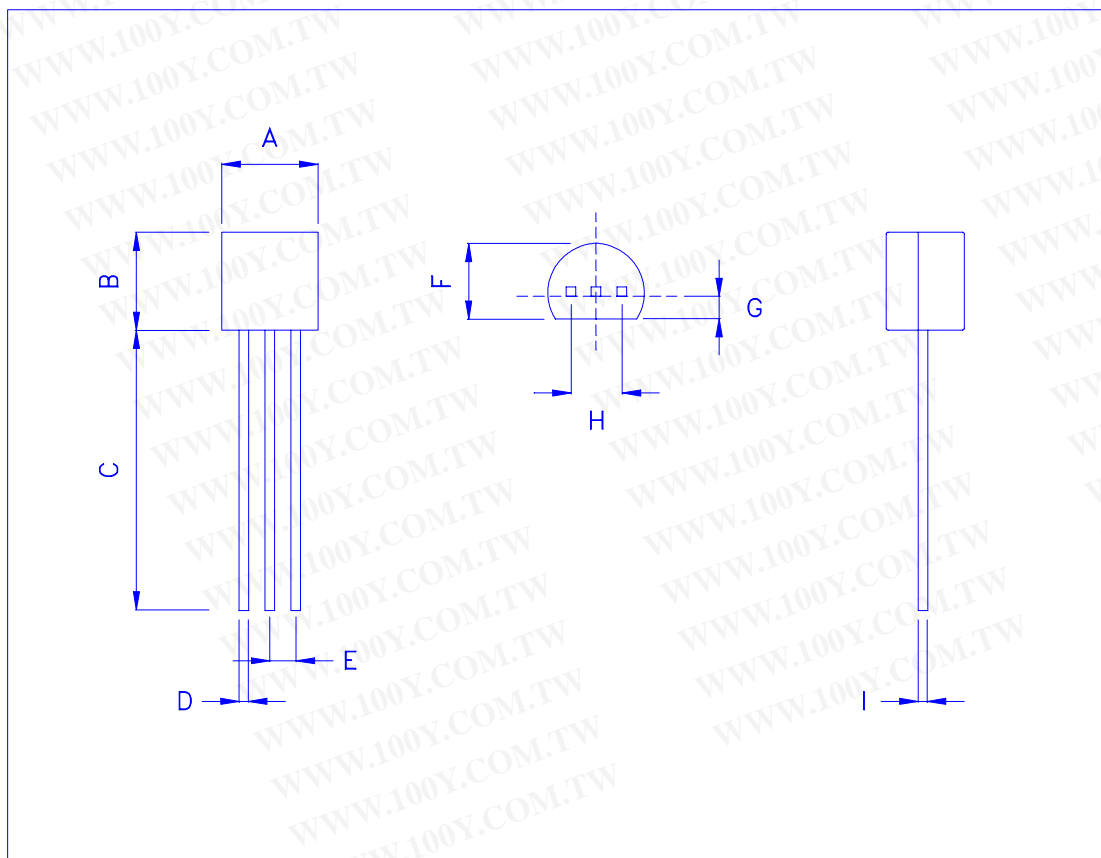

SOT-89 MECHANICAL DATA

Dimension	mm			Dimension	mm		
	Min.	Typ.	Max.		Min.	Typ.	Max.
A	4.3	4.5	4.7	H	1.4	1.5	1.6
B	1.6	1.7	1.8	I	2.8	3.0	3.2
C	0.4	0.5	0.6	J	1.3	1.5	1.7
D	2.4	2.5	2.6	K	3.8	4.2	4.6
E	0.8	1.2	1.4	L	0.3	0.4	0.5
F	0.4	0.45	0.5	M			
G	0.4	0.5	0.6	N			

勝特力材料 886-3-5753170
 勝特力电子(上海) 86-21-54151736
 勝特力电子(深圳) 86-755-83298787
[Http://www.100y.com.tw](http://www.100y.com.tw)

