

## PUSH-PULL FOUR CHANNEL DRIVERS

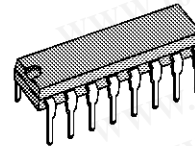
- OUTPUT CURRENT 1A PER CHANNEL
- PEAK OUTPUT CURRENT 2A PER CHANNEL (non repetitive)
- INHIBIT FACILITY
- HIGH NOISE IMMUNITY
- SEPARATE LOGIC SUPPLY
- OVERTEMPERATURE PROTECTION

### DESCRIPTION

The L293B and L293E are quad push-pull drivers capable of delivering output currents to 1A per channel. Each channel is controlled by a TTL-compatible logic input and each pair of drivers (a full bridge) is equipped with an inhibit input which turns off all four transistors. A separate supply input is provided for the logic so that it may be run off a lower voltage to reduce dissipation.

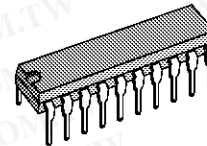
Additionally, the L293E has external connection of sensing resistors, for switchmode control.

The L293B and L293E are package in 16 and 20-pin plastic DIPs respectively ; both use the four center pins to conduct heat to the printed circuit board.



DIP16

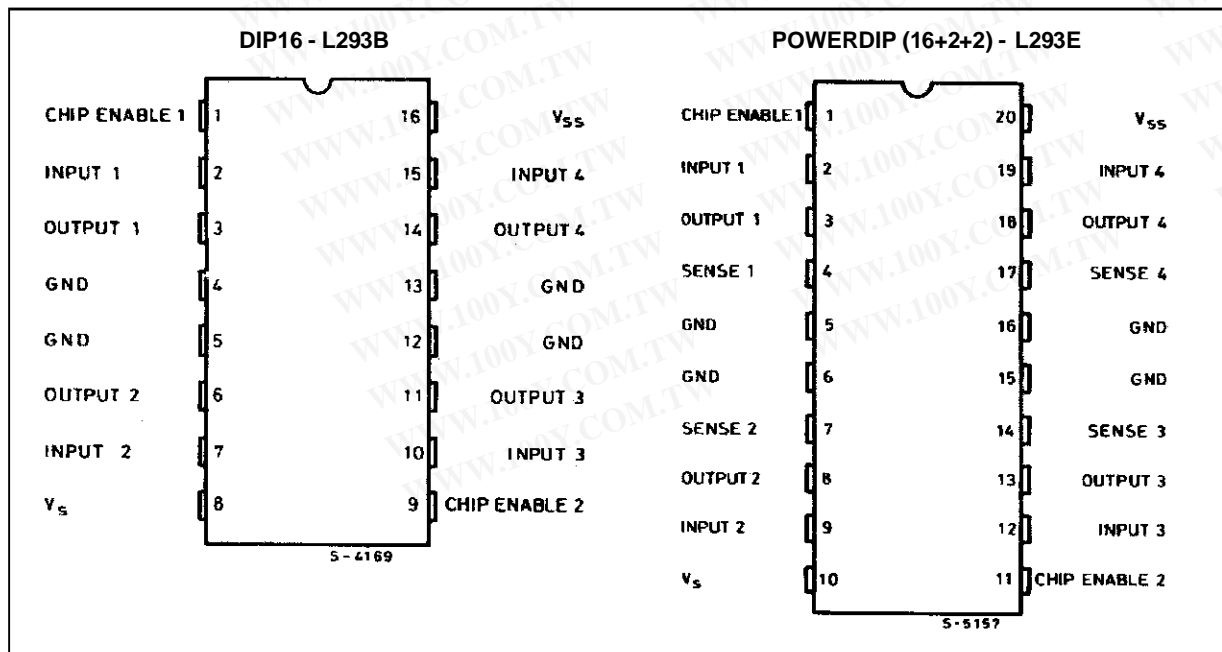
ORDERING NUMBER : L293B



POWERDIP (16 + 2 + 2)

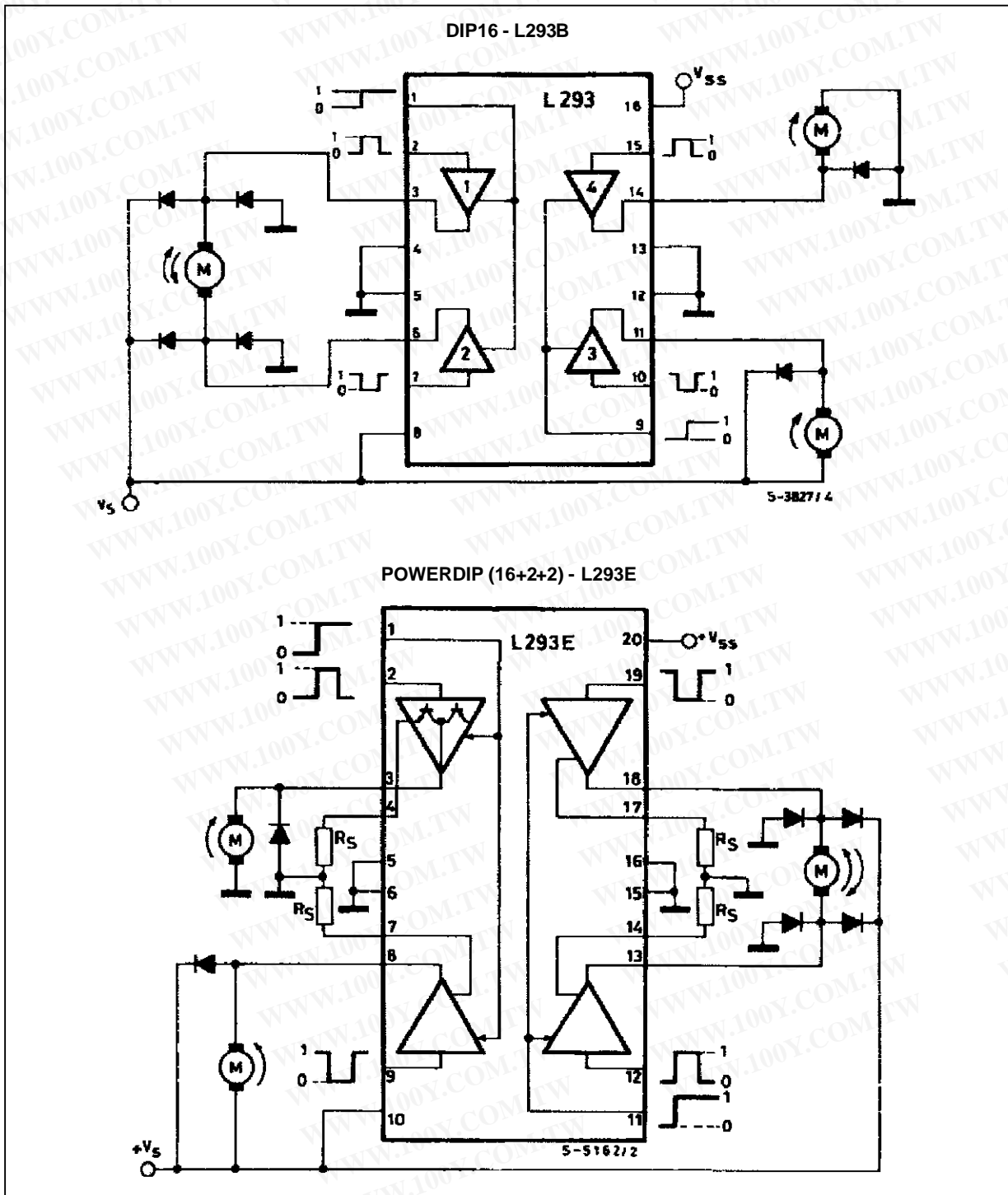
ORDERING NUMBER : L293E

### PIN CONNECTIONS



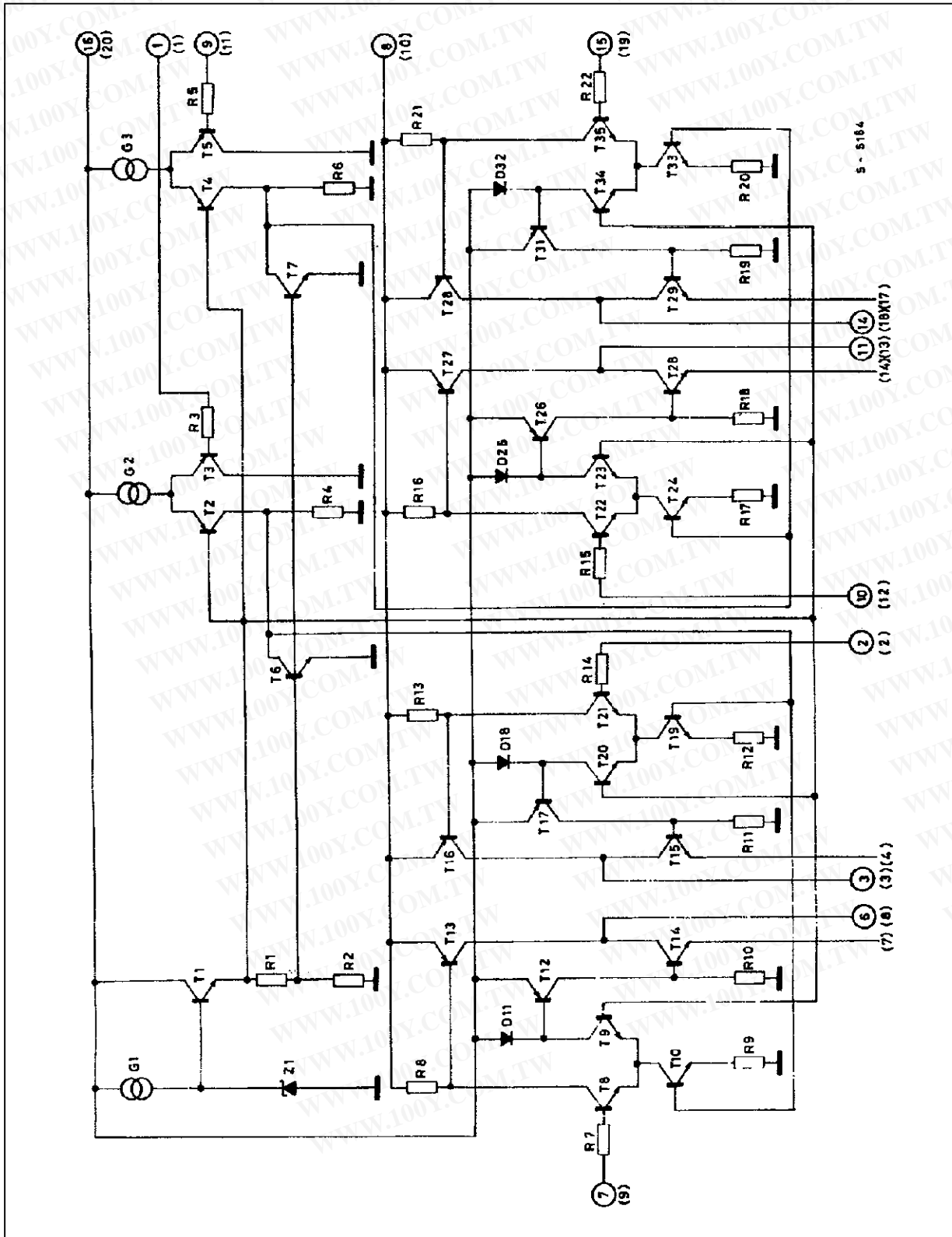
L293B - L293E

BLOCK DIAGRAMS



L293B - L293E

SCHEMATIC DIAGRAM



(\*) In the L293 these points are not externally available. They are internally connected to the ground (substrate).  
 O Pins of L293                      () Pins of L293E.

## L293B - L293E

### ABSOLUTE MAXIMUM RATINGS

Symbol	Parameter	Value	Unit
V <sub>s</sub>	Supply Voltage	36	V
V <sub>ss</sub>	Logic Supply Voltage	36	V
V <sub>i</sub>	Input Voltage	7	V
V <sub>inh</sub>	Inhibit Voltage	7	V
I <sub>out</sub>	Peak Output Current (non repetitive t = 5ms)	2	A
P <sub>tot</sub>	Total Power Dissipation at T <sub>ground-pins</sub> = 80°C	5	W
T <sub>stg</sub> , T <sub>j</sub>	Storage and Junction Temperature	-40 to +150	°C

### THERMAL DATA

Symbol	Parameter	Value	Unit
R <sub>th j-case</sub>	Thermal Resistance Junction-case	Max. 14	°C/W
R <sub>th j-amb</sub>	Thermal Resistance Junction-ambient	Max. 80	°C/W

### ELECTRICAL CHARACTERISTICS

For each channel, V<sub>s</sub> = 24V, V<sub>ss</sub> = 5V, T<sub>amb</sub> = 25°C, unless otherwise specified

Symbol	Parameter	Test Conditions	Min.	TYp.	Max.	Unit
V <sub>s</sub>	Supply Voltage		V <sub>ss</sub>		36	V
V <sub>ss</sub>	Logic Supply Voltage		4.5		36	V
I <sub>s</sub>	Total Quiescent Supply Current	V <sub>i</sub> = L I <sub>o</sub> = 0 V <sub>inh</sub> = H V <sub>i</sub> = H I <sub>o</sub> = 0 V <sub>inh</sub> = H V <sub>inh</sub> = L		2 16	6 24 4	mA
I <sub>ss</sub>	Total Quiescent Logic Supply Current	V <sub>i</sub> = L I <sub>o</sub> = 0 V <sub>inh</sub> = H V <sub>i</sub> = H I <sub>o</sub> = 0 V <sub>inh</sub> = H V <sub>inh</sub> = L		44 16 16	60 22 24	mA
V <sub>iL</sub>	Input Low Voltage		-0.3		1.5	V
V <sub>iH</sub>	Input High Voltage	V <sub>ss</sub> ≤ 7V V <sub>ss</sub> > 7V	2.3 2.3		V <sub>ss</sub> 7	V
I <sub>iL</sub>	Low Voltage Input Current	V <sub>il</sub> = 1.5V			-10	μA
I <sub>iH</sub>	High Voltage Input Current	2.3V ≤ V <sub>iH</sub> ≤ V <sub>ss</sub> - 0.6V		30	100	μA
V <sub>inhL</sub>	Inhibit Low Voltage		-0.3		1.5	V
V <sub>inhH</sub>	Inhibit High Voltage	V <sub>ss</sub> ≤ 7V V <sub>ss</sub> > 7V	2.3 2.3		V <sub>ss</sub> 7	V
I <sub>inhL</sub>	Low Voltage Inhibit Current	V <sub>inhL</sub> = 1.5V		-30	-100	μA
I <sub>inhH</sub>	High Voltage Inhibit Current	2.3V ≤ V <sub>inhH</sub> ≤ V <sub>ss</sub> - 0.6V			±10	μA
V <sub>CEsatH</sub>	Source Output Saturation Voltage	I <sub>o</sub> = -1A		1.4	1.8	V
V <sub>CEsatL</sub>	Sink Output Saturation Voltage	I <sub>o</sub> = 1A		1.2	1.8	V
V <sub>SENS</sub>	Sensing Voltage (pins 4, 7, 14, 17) (**)				2	V
t <sub>r</sub>	Rise Time	0.1 to 0.9 V <sub>o</sub> (*)		250		ns
t <sub>f</sub>	Fall Time	0.9 to 0.1 V <sub>o</sub> (*)		250		ns
t <sub>on</sub>	Turn-on Delay	0.5 V <sub>i</sub> to 0.5 V <sub>o</sub> (*)		750		ns
t <sub>off</sub>	Turn-off Delay	0.5 V <sub>i</sub> to 0.5 V <sub>o</sub> (*)		200		ns

\* See figure 1

\*\* Referred to L293E

### TRUTH TABLE

V <sub>i</sub> (each channel)	V <sub>o</sub>	V <sub>inh</sub> ( <sup>∞</sup> )
H	H	H
L	L	H
H	X ( <sup>o</sup> )	L
L	X ( <sup>o</sup> )	L

(\*) High output impedance

(\*\*) Relative to the considerate channel

L293B - L293E

Figure 1 : Switching Timers

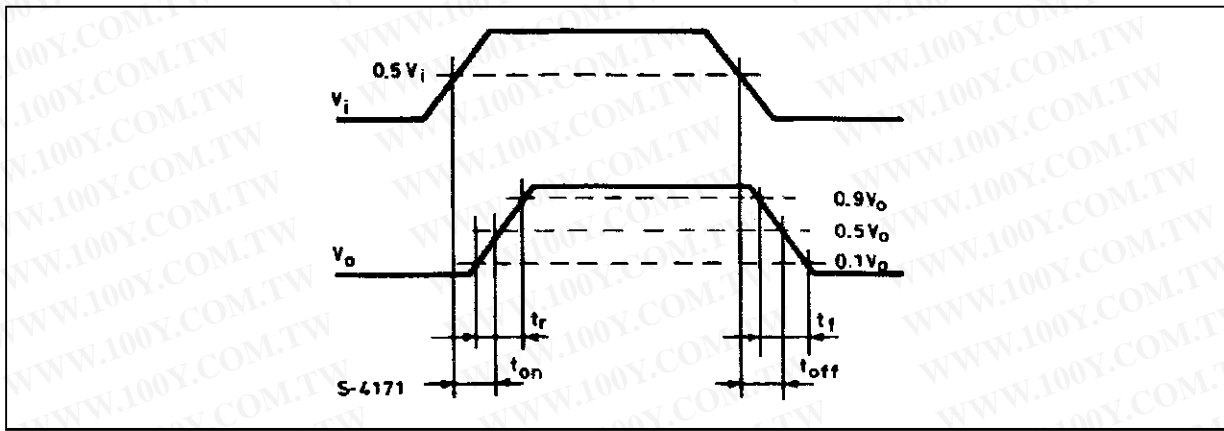


Figure 2 : Saturation voltage versus Output Current

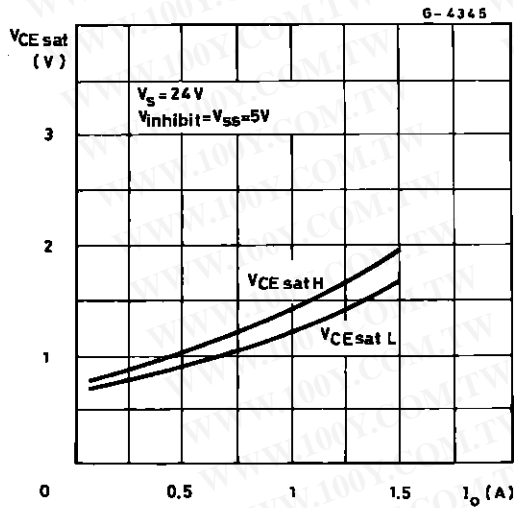


Figure 4 : Sink Saturation Voltage versus Ambient Temperature

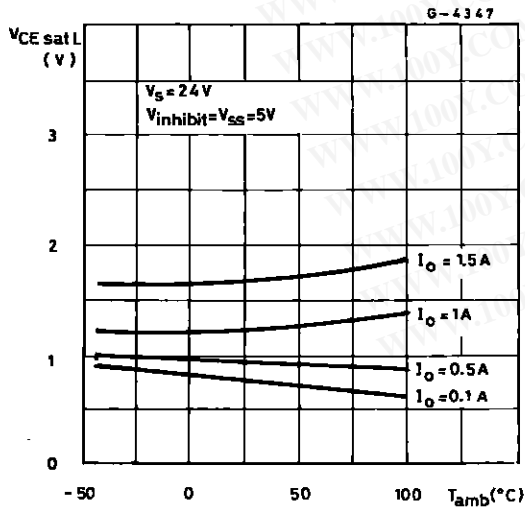


Figure 3 : Source Saturation Voltage versus Ambient Temperature

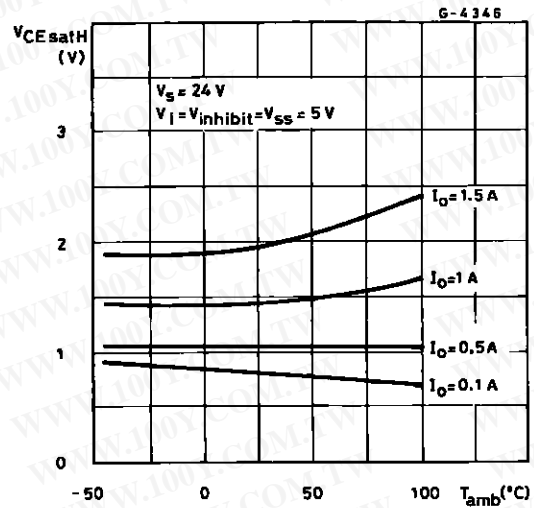
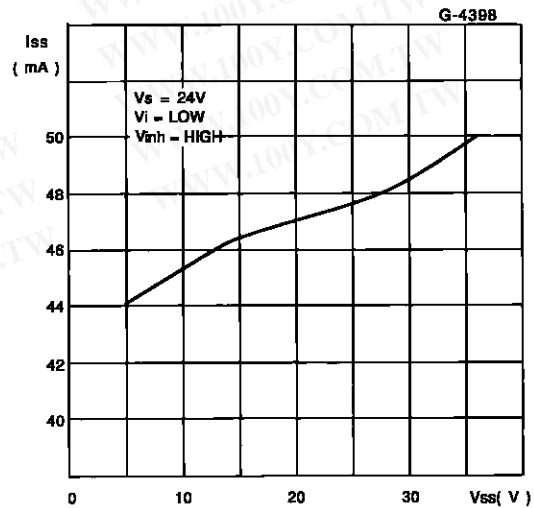
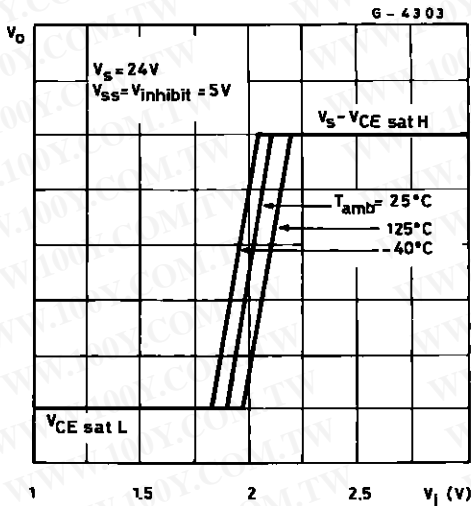


Figure 5 : Quiescent Logic Supply Current versus Logic Supply Voltage

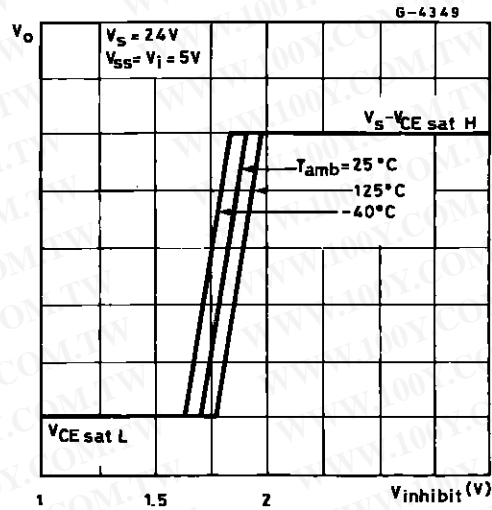


**L293B - L293E**

**Figure 6 :** Output Voltage versus Input Voltage

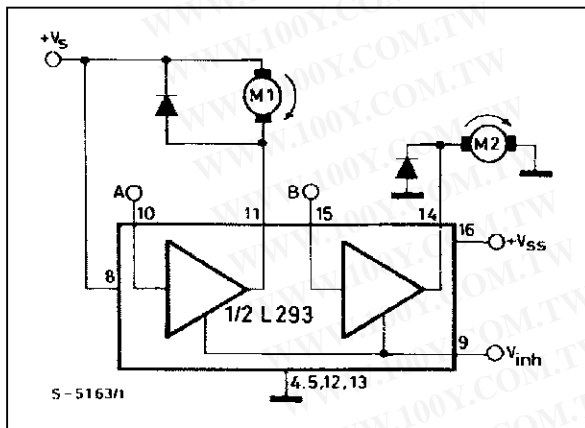


**Figure 7 :** Output Voltage versus Inhibit Voltage



**APPLICATION INFORMATION**

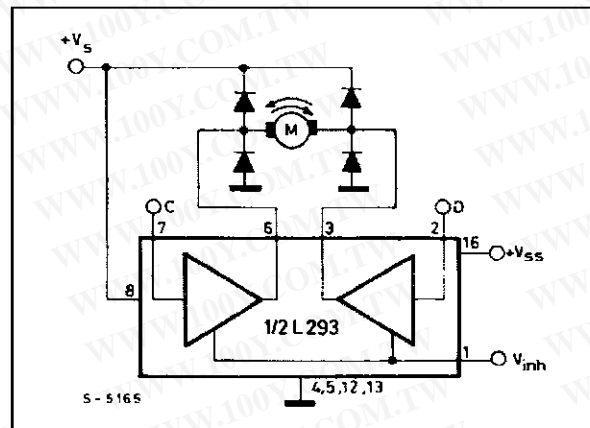
**Figure 8 :** DC Motor Controls  
 (with connection to ground and to the supply voltage)



V <sub>inh</sub>	A	M1	B	M2
H	H	Fast Motor Stop	H	Run
H	L	Run	L	Fast Motor Stop
L	X	Free Running Motor Stop	X	Free Running Motor Stop

L = Low      H = High      X = Don't Care

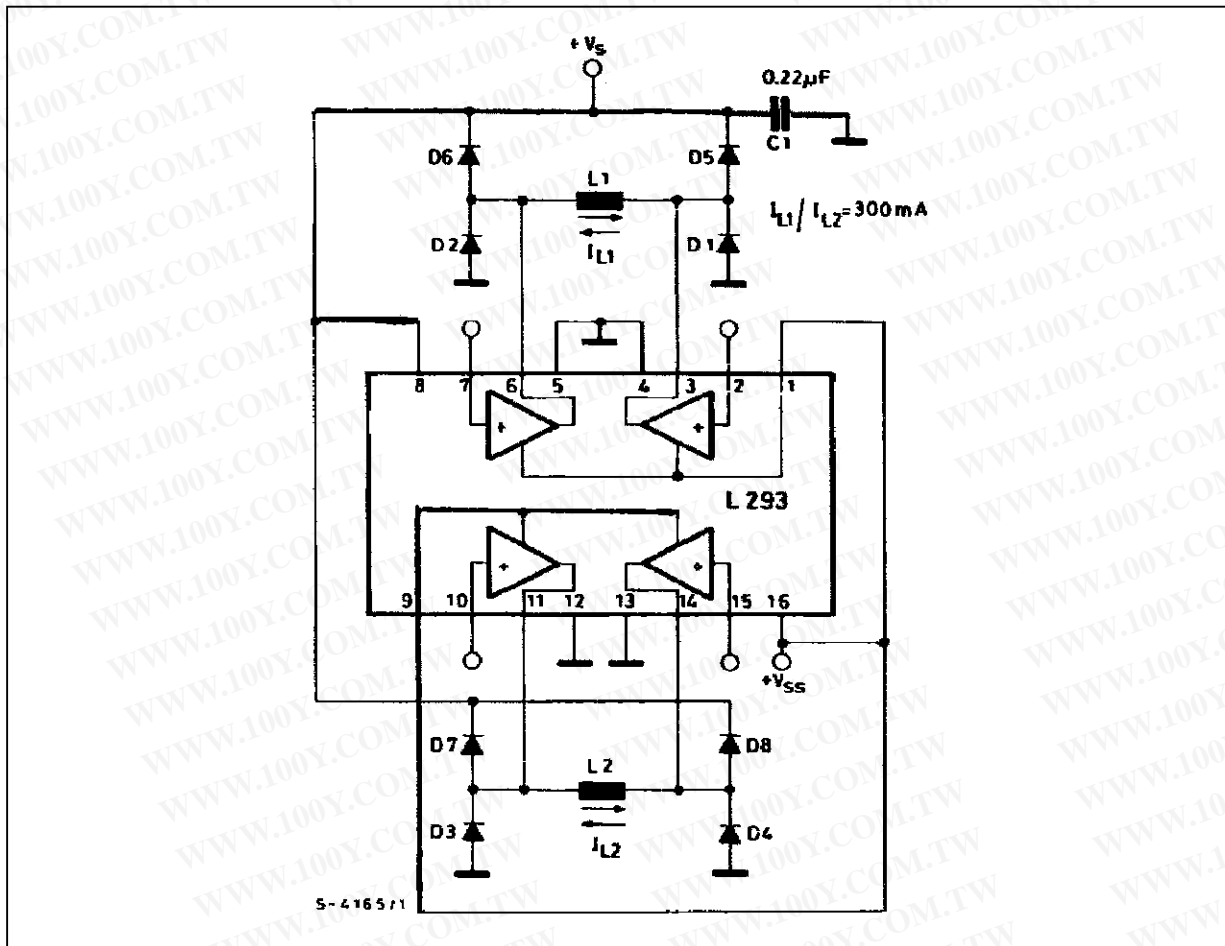
**Figure 9 :** Bidirectional DC Motor Control



Inputs	Function	
V <sub>inh</sub> = H	C = H ; D = L	Turn Right
	C = L ; D = H	Turn Left
	C = D	Fast Motor Stop
V <sub>inh</sub> = L	C = X ; D = X	Free Running Motor Stop

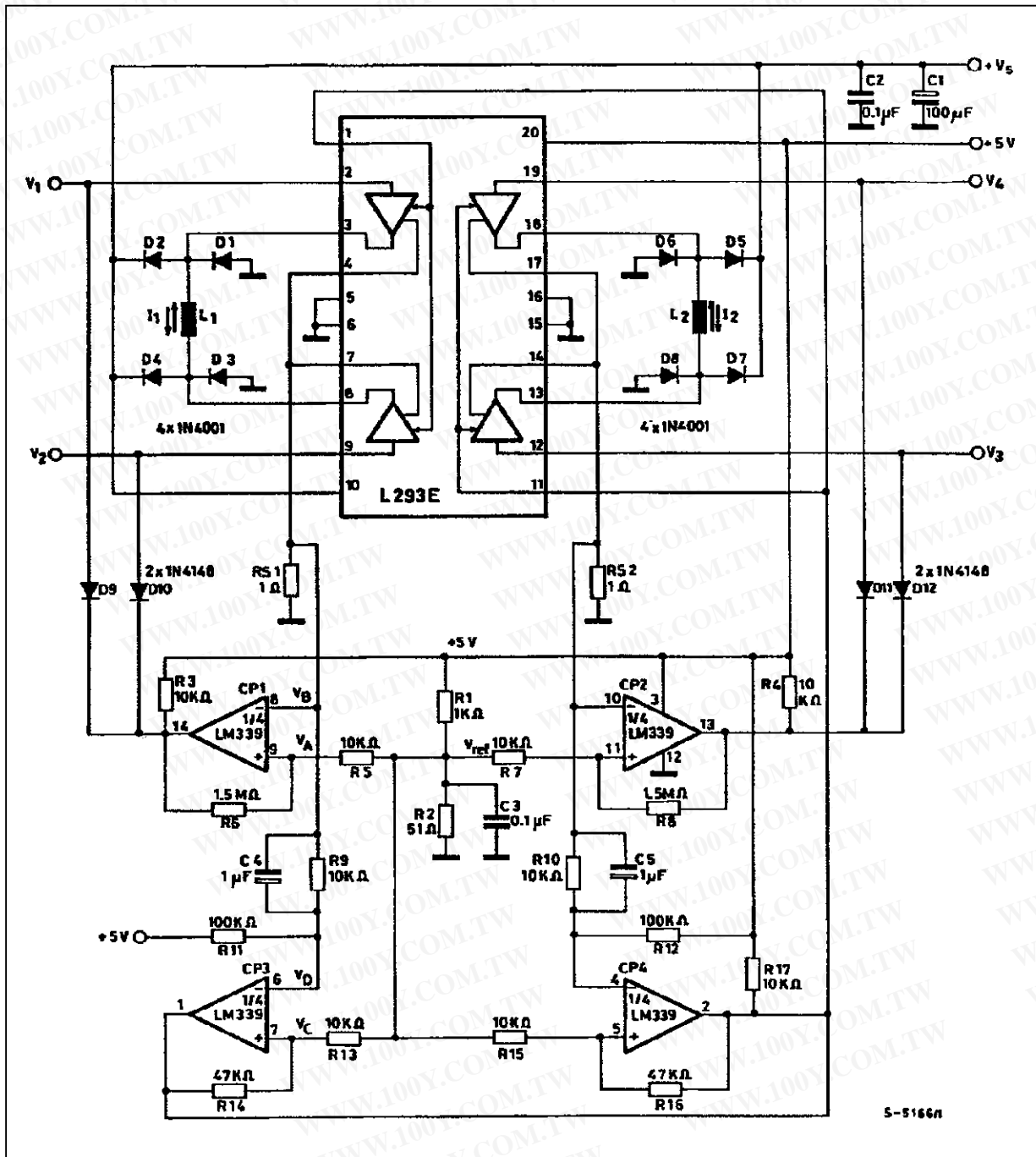
L = Low      H = High      X = Don't Care

Figure 10 : Bipolar Stepping Motor Control



L293B - L293E

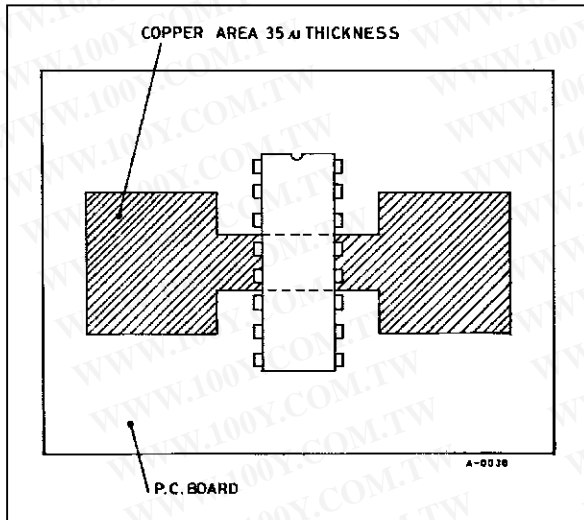
Figure 11 :Stepping Motor Driver with Phase Current Control and Short Circuit Protection



### MOUNTING INSTRUCTIONS

The  $R_{thj-amb}$  of the L293B and the L293E can be reduced by soldering the GND pins to a suitable copper area of the printed circuit board as shown in figure 12 or to an external heatsink (figure 13).

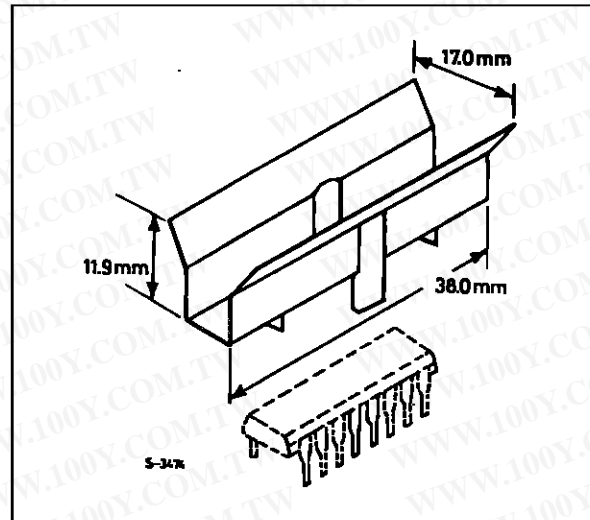
**Figure 12** : Example of P.C. Board Copper Area which is Used as Heatsink



During soldering the pins temperature must not exceed 260°C and the soldering time must not be longer than 12 seconds.

The external heatsink or printed circuit copper area must be connected to electrical ground.

**Figure 13** : External Heatsink Mounting Example ( $R_{th} = 30^{\circ}\text{C/W}$ )

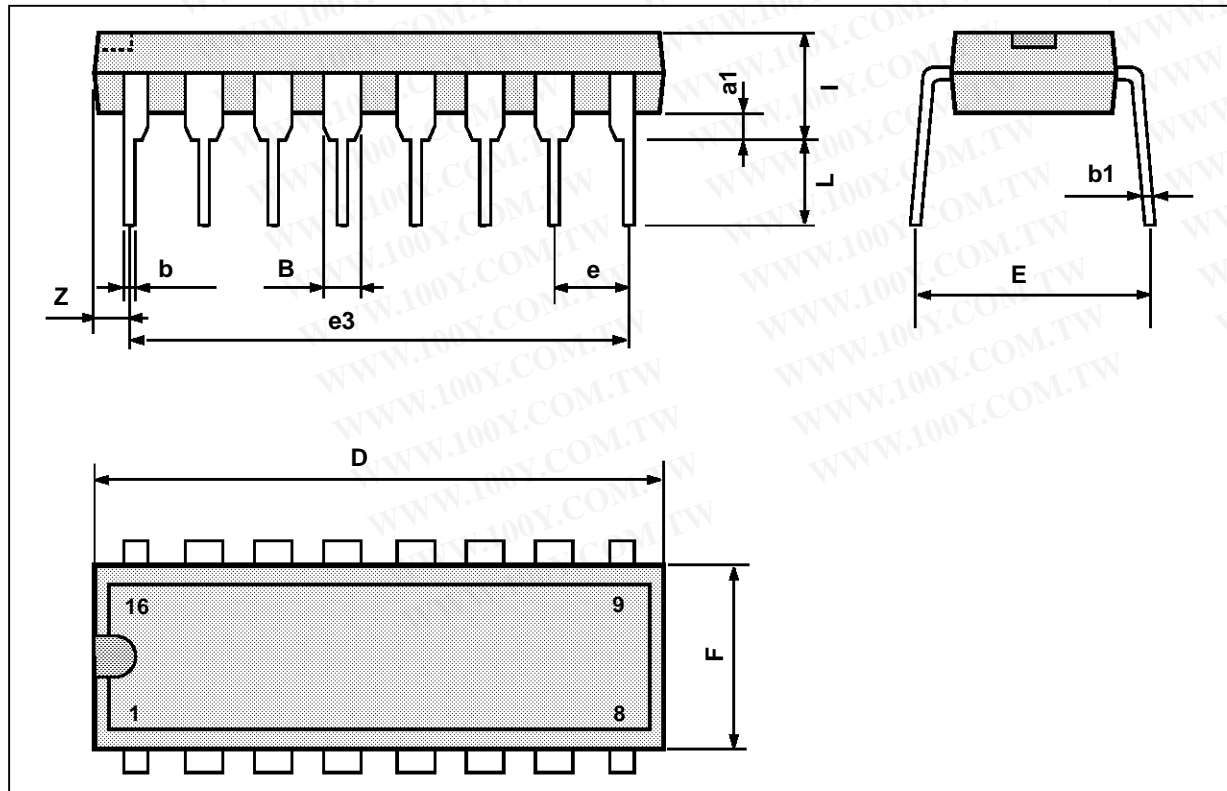


**L293B - L293E**

**DIP16 PACKAGE MECHANICAL DATA**

Dimensions	Millimeters			Inches		
	Min.	Typ.	Max.	Min.	Typ.	Max.
a1	0.51			0.020		
B	0.77		1.65	0.030		0.065
b		0.5			0.020	
b1		0.25			0.010	
D			20			0.787
E		8.5			0.335	
e		2.54			0.100	
e3		17.78			0.700	
F			7.1			0.280
i			5.1			0.201
L		3.3			0.130	
Z			1.27			0.050

DIP16PW/TBL

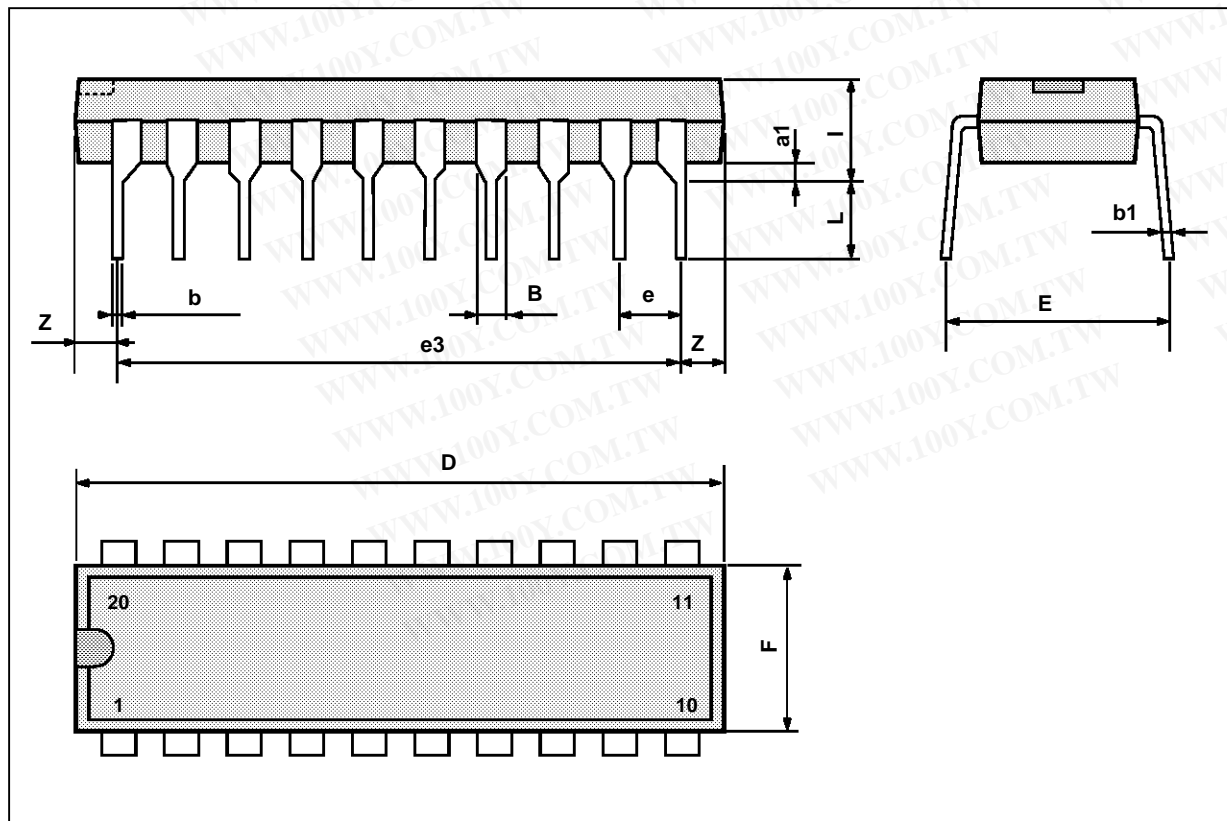


PMDIP16W/E/PS

POWERDIP (16+2+2) PACKAGE MECHANICAL DATA

Dimensions	Millimeters			Inches		
	Min.	Typ.	Max.	Min.	Typ.	Max.
a1	0.51			0.020		
B	0.85		1.4	0.033		0.055
b		0.5			0.020	
b1	0.38		0.5	0.015		0.020
D			24.8			0.976
E		8.8			0.346	
e		2.54			0.100	
e3		22.86			0.900	
F			7.1			0.280
i			5.1			0.201
L		3.3			0.130	
Z			1.27			0.050

DIP20PW.TBL



PMDIP20WEPS