

PUSH-PULL FOUR CHANNEL DRIVERS

- OUTPUT CURRENT 1A PER CHANNEL
- PEAK OUTPUT CURRENT 2A PER CHANNEL (non repetitive)
- INHIBIT FACILITY
- HIGH NOISE IMMUNITY
- SEPARATE LOGIC SUPPLY
- OVERTEMPERATURE PROTECTION

DESCRIPTION

The L293B and L293E are quad push-pull drivers capable of delivering output currents to 1A per channel. Each channel is controlled by a TTL-compatible logic input and each pair of drivers (a full bridge) is equipped with an inhibit input which turns off all four transistors. A separate supply input is provided for the logic so that it may be run off a lower voltage to reduce dissipation.

Additionally, the L293E has external connection of sensing resistors, for switchmode control.

The L293B and L293E are package in 16 and 20-pin plastic DIPs respectively ; both use the four center pins to conduct heat to the printed circuit board.

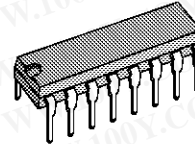

DIP16

ORDERING NUMBER : L293B

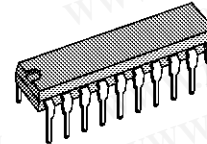

POWERDIP (16 + 2 + 2)

ORDERING NUMBER : L293E

PIN CONNECTIONS

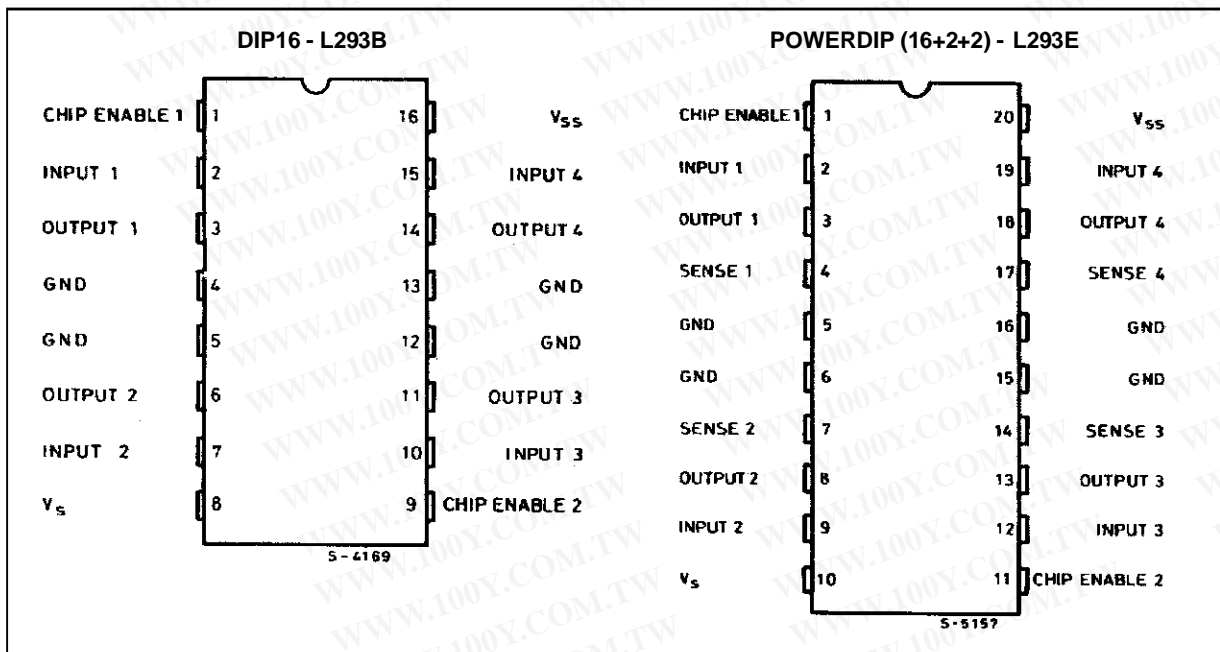

L293B - L293E

BLOCK DIAGRAMS

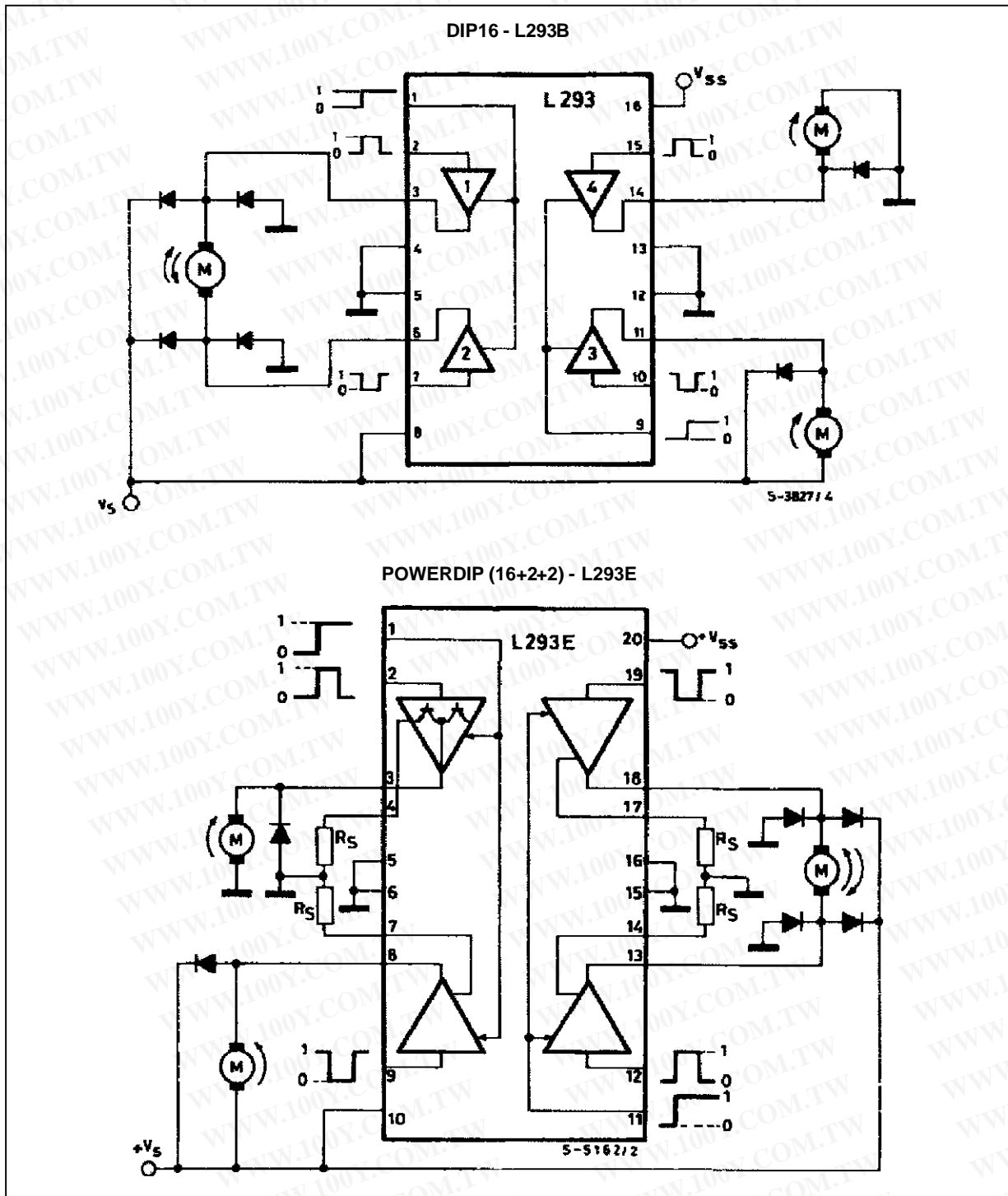

SCHEMATIC DIAGRAM

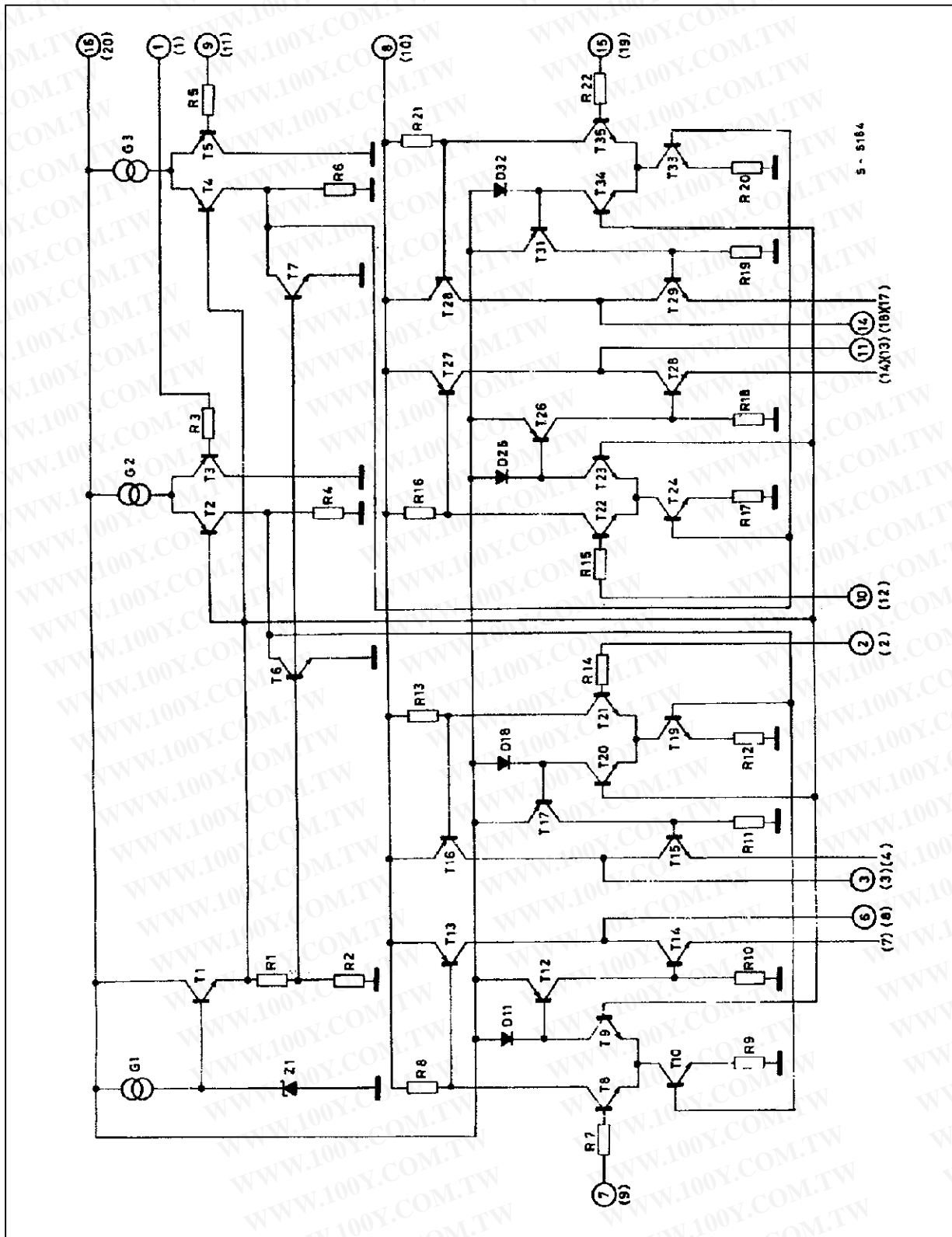

(*) In the L293 these points are not externally available. They are internally connected to the ground (substrate).
 O Pins of L293 () Pins of L293E.

L293B - L293E

ABSOLUTE MAXIMUM RATINGS

Symbol	Parameter	Value	Unit
V_s	Supply Voltage	36	V
V_{ss}	Logic Supply Voltage	36	V
V_i	Input Voltage	7	V
V_{inh}	Inhibit Voltage	7	V
I_{out}	Peak Output Current (non repetitive t = 5ms)	2	A
P_{tot}	Total Power Dissipation at $T_{ground-pins} = 80^{\circ}C$	5	W
T_{stg}, T_j	Storage and Junction Temperature	-40 to +150	$^{\circ}C$

THERMAL DATA

Symbol	Parameter	Value	Unit
$R_{th\ j-case}$	Thermal Resistance Junction-case	Max. 14	$^{\circ}C/W$
$R_{th\ j-amb}$	Thermal Resistance Junction-ambient	Max. 80	$^{\circ}C/W$

ELECTRICAL CHARACTERISTICS

For each channel, $V_s = 24V$, $V_{ss} = 5V$, $T_{amb} = 25^{\circ}C$, unless otherwise specified

Symbol	Parameter	Test Conditions	Min.	TYp.	Max.	Unit
V_s	Supply Voltage		V_{ss}		36	V
V_{ss}	Logic Supply Voltage		4.5		36	V
I_s	Total Quiescent Supply Current	$V_i = L \quad I_o = 0 \quad V_{inh} = H$ $V_i = H \quad I_o = 0 \quad V_{inh} = H$ $V_i = H \quad I_o = 0 \quad V_{inh} = L$		2 16	6 24 4	mA
I_{ss}	Total Quiescent Logic Supply Current	$V_i = L \quad I_o = 0 \quad V_{inh} = H$ $V_i = H \quad I_o = 0 \quad V_{inh} = H$ $V_i = H \quad I_o = 0 \quad V_{inh} = L$		44 16 16	60 22 24	mA
V_{iL}	Input Low Voltage		-03.		1.5	V
V_{iH}	Input High Voltage	$V_{ss} \leq 7V$ $V_{ss} > 7V$	2.3 2.3		V_{ss} 7	V
I_{iL}	Low Voltage Input Current	$V_{iL} = 1.5V$			-10	μA
I_{iH}	High Voltage Input Current	$2.3V \leq V_{iH} \leq V_{ss} - 0.6V$		30	100	μA
V_{inhL}	Inhibit Low Voltage		-0.3		1.5	V
V_{inhH}	Inhibit High Voltage	$V_{ss} \leq 7V$ $V_{ss} > 7V$	2.3 2.3		V_{ss} 7	V
I_{inhL}	Low Voltage Inhibit Current	$V_{inhL} = 1.5V$		-30	-100	μA
I_{inhH}	High Voltage Inhibit Current	$2.3V \leq V_{inhH} \leq V_{ss} - 0.6V$			± 10	μA
V_{CEsatH}	Source Output Saturation Voltage	$I_o = -1A$		1.4	1.8	V
V_{CEsatL}	Sink Output Saturation Voltage	$I_o = 1A$		1.2	1.8	V
V_{SENS}	Sensing Voltage (pins 4, 7, 14, 17) (**)				2	V
t_r	Rise Time	0.1 to 0.9 V_o (*)		250		ns
t_f	Fall Time	0.9 to 0.1 V_o (*)		250		ns
t_{on}	Turn-on Delay	0.5 V_i to 0.5 V_o (*)		750		ns
t_{off}	Turn-off Delay	0.5 V_i to 0.5 V_o (*)		200		ns

* See figure 1

** Referred to L293E

TRUTH TABLE

V_i (each channel)	V_o	$V_{inh}^{(*)}$
H	H	H
L	L	H
H	X ^(*)	L
L	X ^(*)	L

(*) High output impedance

(**) Relative to the considerate channel

Figure 1 : Switching Timers

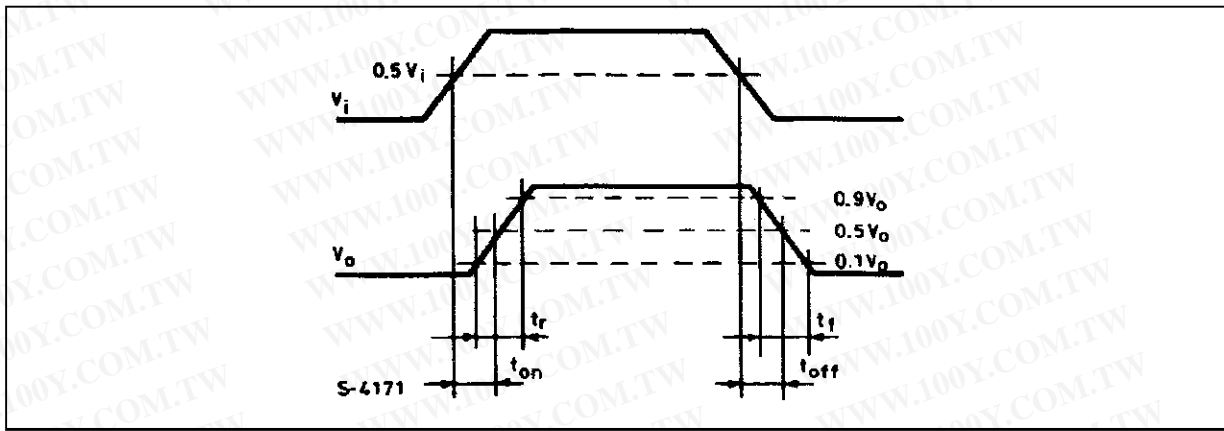

Figure 2 : Saturation voltage versus Output Current

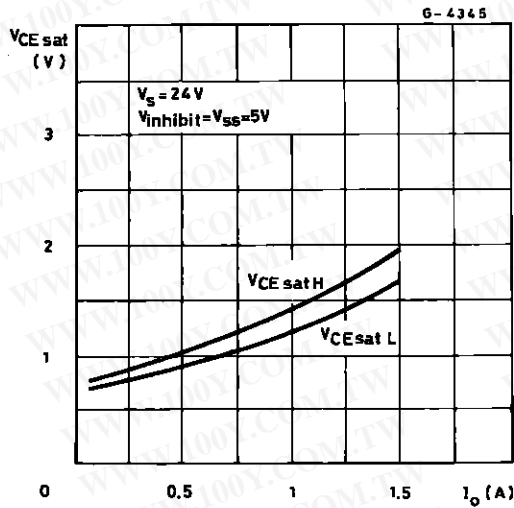

Figure 4 : Sink Saturation Voltage versus Ambient Temperature

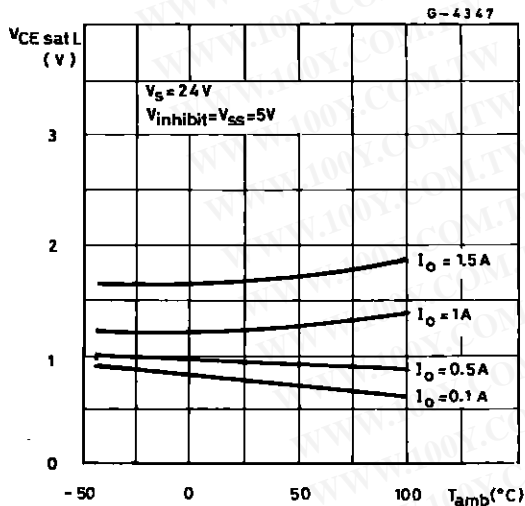

Figure 3 : Source Saturation Voltage versus Ambient Temperature

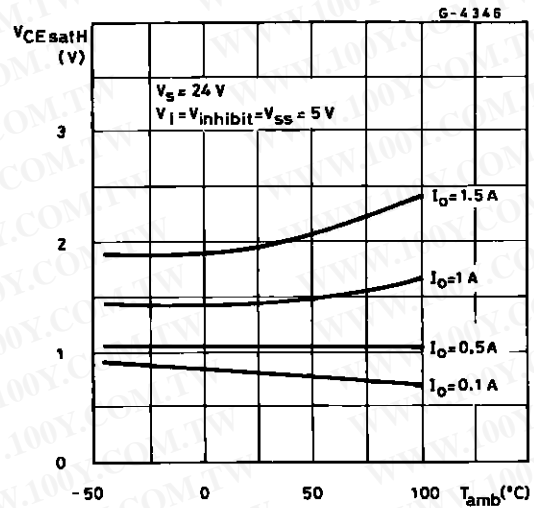
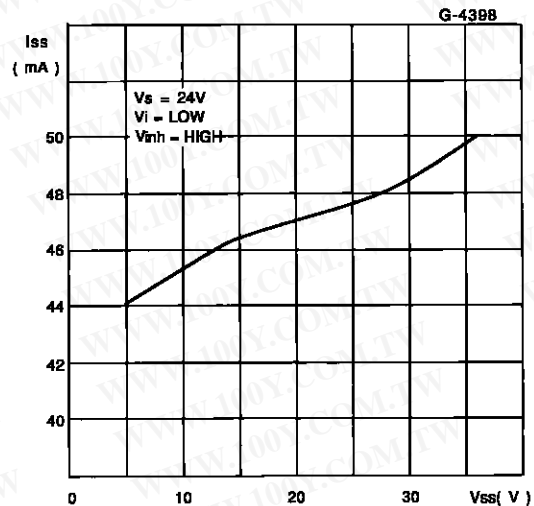

Figure 5 : Quiescent Logic Supply Current versus Logic Supply Voltage



L293B - L293E

Figure 6 : Output Voltage versus Input Voltage

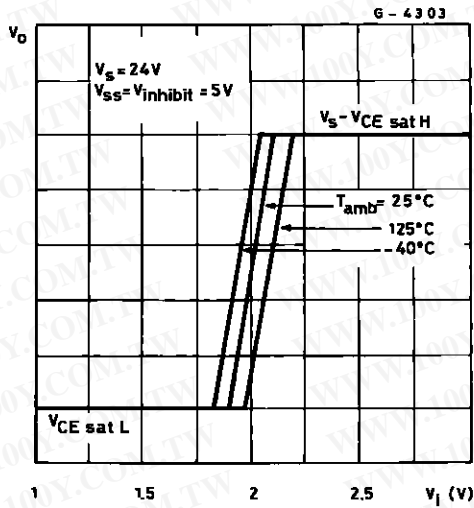
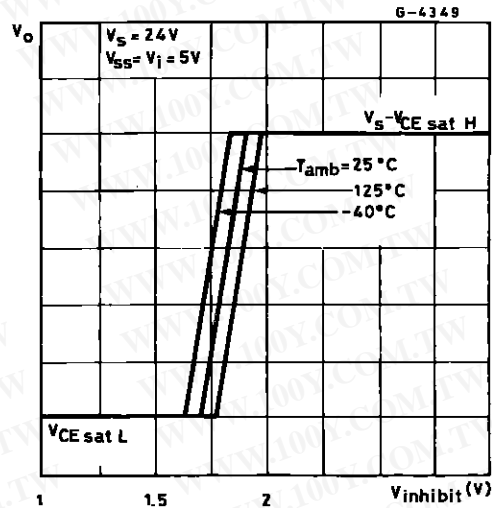
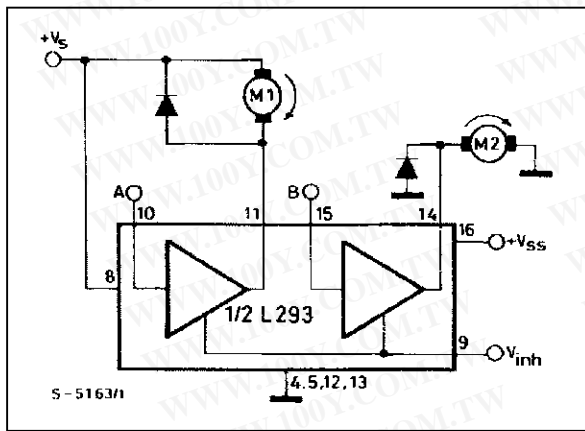

Figure 7 : Output Voltage versus Inhibit Voltage



APPLICATION INFORMATION

Figure 8 : DC Motor Controls
 (with connection to ground and to the supply voltage)



V _{inh}	A	M1	B	M2
H	H	Fast Motor Stop	H	Run
H	L	Run	L	Fast Motor Stop
L	X	Free Running Motor Stop	X	Free Running Motor Stop

L = Low H = High X = Don't Care

Figure 9 : Bidirectional DC Motor Control

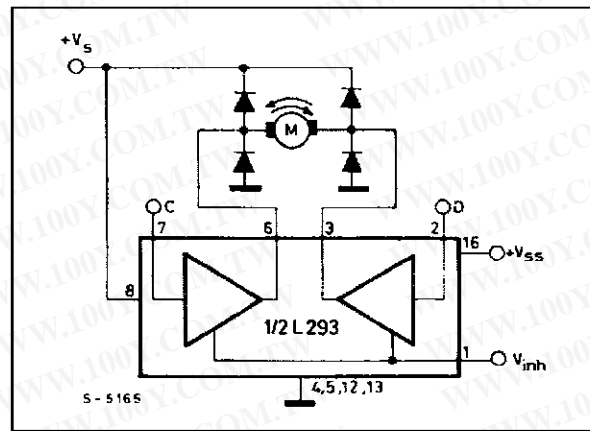

Inputs	Function	
V _{inh} = H	C = H ; D = L	Turn Right
	C = L ; D = H	Turn Left
	C = D	Fast Motor Stop
V _{inh} = L	C = X ; D = X	Free Running Motor Stop

L = Low H = High X = Don't Care

Figure 10 : Bipolar Stepping Motor Control

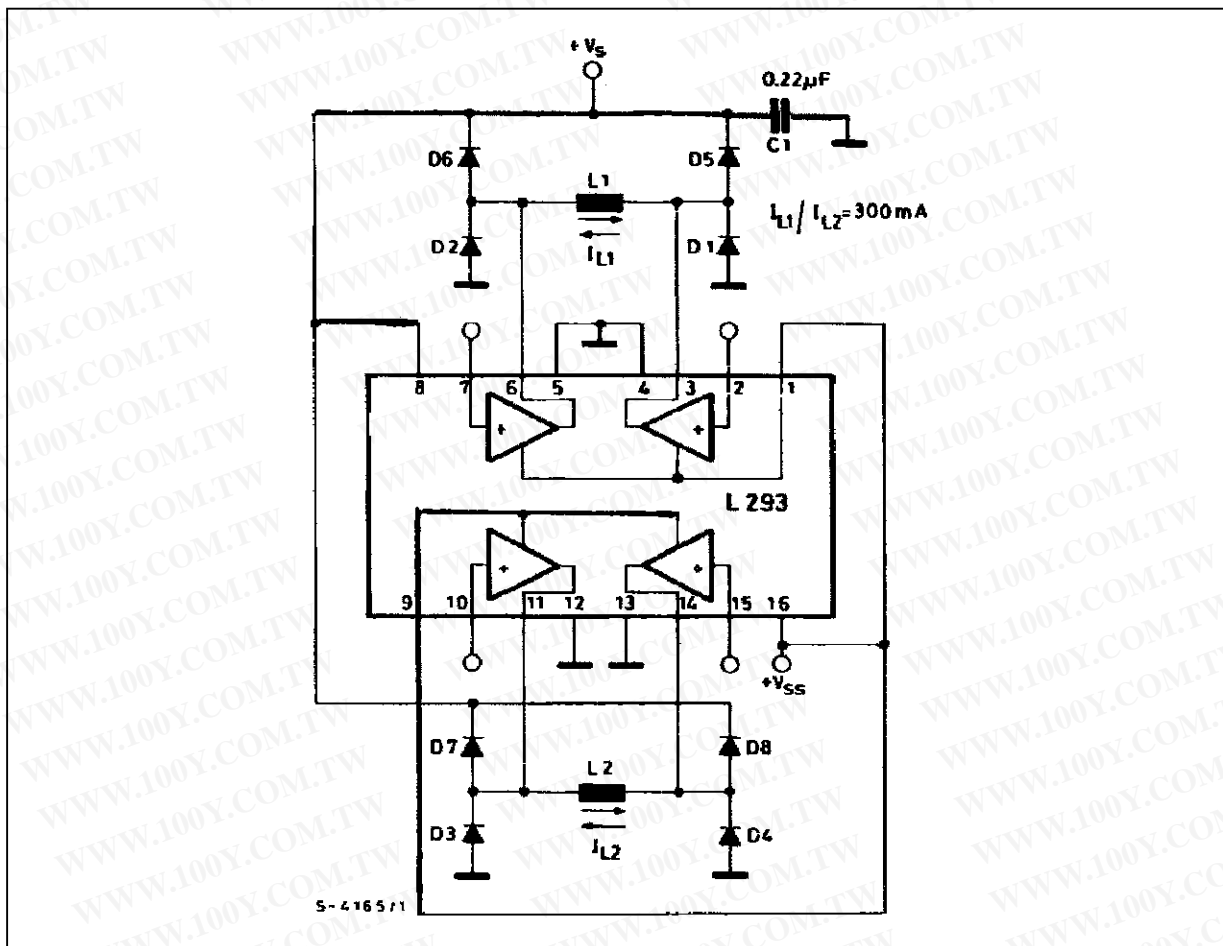

勝特力材料 886-3-5753170
 勝特力电子(上海) 86-21-54151736
 勝特力电子(深圳) 86-755-83298787
[Http://www.100y.com.tw](http://www.100y.com.tw)

L293B - L293E

Figure 11 :Stepping Motor Driver with Phase Current Control and Short Circuit Protection

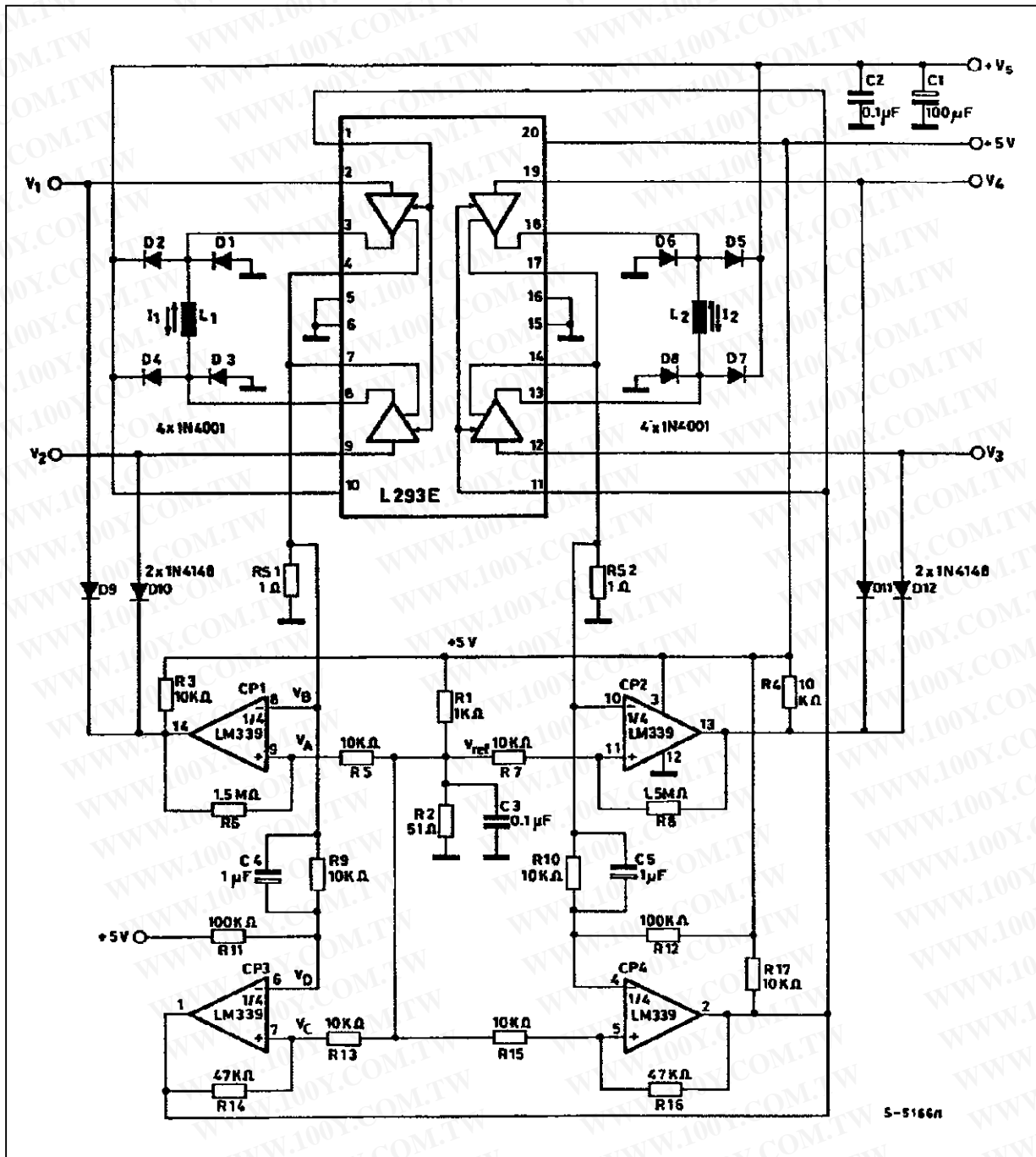

勝特力材料 886-3-5753170
 勝特力电子(上海) 86-21-54151736
 勝特力电子(深圳) 86-755-83298787
[Http://www.100y.com.tw](http://www.100y.com.tw)

MOUNTING INSTRUCTIONS

The $R_{th\ j-amb}$ of the L293B and the L293E can be reduced by soldering the GND pins to a suitable copper area of the printed circuit board as shown in figure 12 or to an external heatsink (figure 13).

Figure 12 :Example of P.C. Board Copper Area which is Used as Heatsink

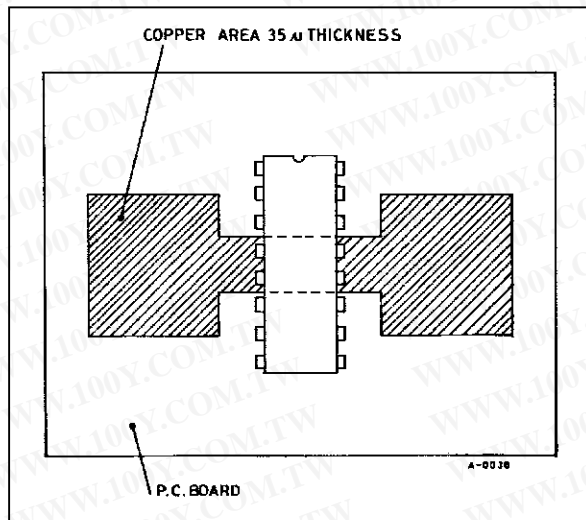

During soldering the pins temperature must not exceed 260°C and the soldering time must not be longer than 12 seconds.

The external heatsink or printed circuit copper area must be connected to electrical ground.

Figure 13 :External Heatsink Mounting Example ($R_{th} = 30^{\circ}\text{C/W}$)

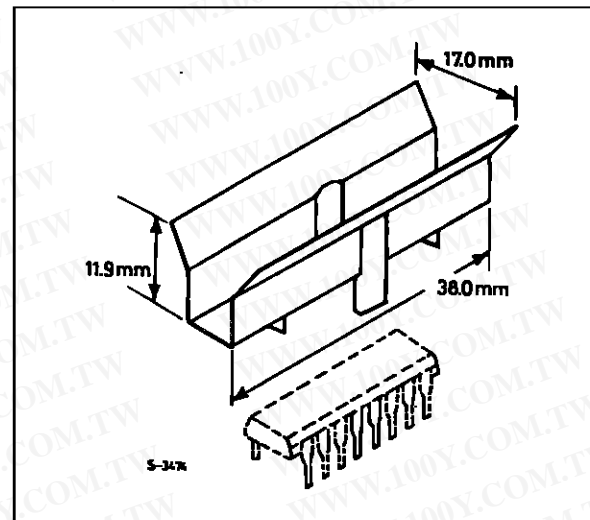

勝特力材料 886-3-5753170
 勝特力电子(上海) 86-21-54151736
 勝特力电子(深圳) 86-755-83298787
[Http://www.100y.com.tw](http://www.100y.com.tw)

L293B - L293E

DIP16 PACKAGE MECHANICAL DATA

Dimensions	Millimeters			Inches		
	Min.	Typ.	Max.	Min.	Typ.	Max.
a1	0.51			0.020		
B	0.77		1.65	0.030		0.065
b		0.5			0.020	
b1		0.25			0.010	
D			20			0.787
E		8.5			0.335	
e		2.54			0.100	
e3		17.78			0.700	
F			7.1			0.280
i			5.1			0.201
L		3.3			0.130	
Z			1.27			0.050

DIP16PW:TBL

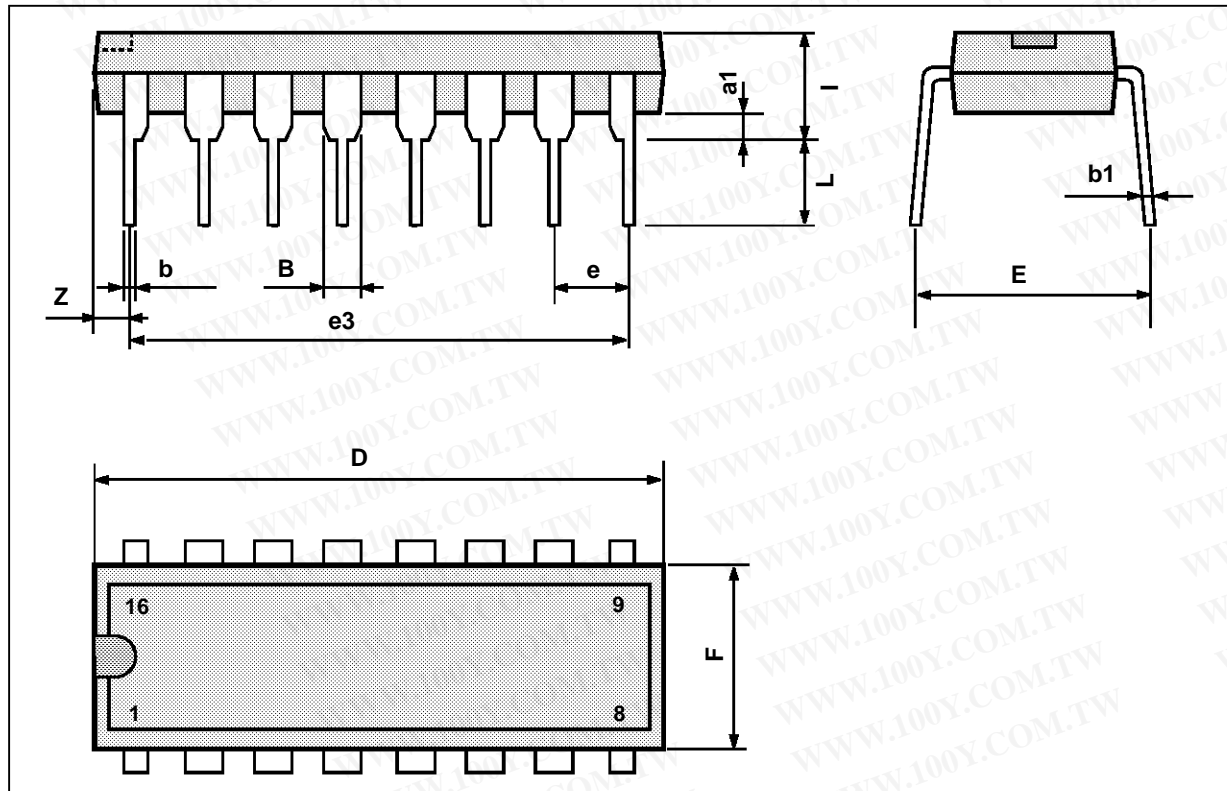

PMDIP16W/E/PS

POWERDIP (16+2+2) PACKAGE MECHANICAL DATA

Dimensions	Millimeters			Inches		
	Min.	Typ.	Max.	Min.	Typ.	Max.
a1	0.51			0.020		
B	0.85		1.4	0.033		0.055
b		0.5			0.020	
b1	0.38		0.5	0.015		0.020
D			24.8			0.976
E		8.8			0.346	
e		2.54			0.100	
e3		22.86			0.900	
F			7.1			0.280
i			5.1			0.201
L		3.3			0.130	
Z			1.27			0.050

DIP20PW.TBL

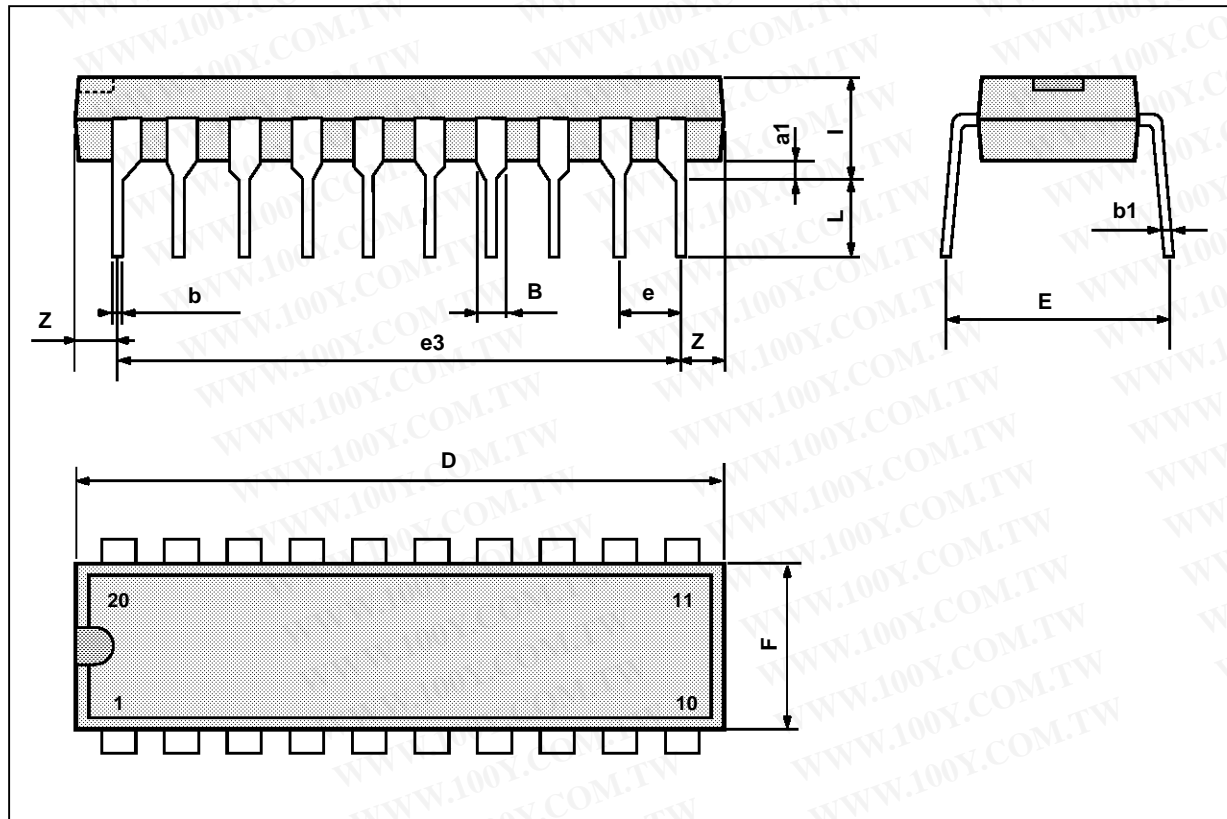

PMDIP20WEPS