

DUAL OPERATIONAL AMPLIFIER

- In the Linear Mode the Input Common Mode Voltage Range Includes Ground.
- Two Internally Compensated OP Amps are in Single Package.
- Low Power Dissipation and Power Drain Suitable for Battery Operation.
- Differential Input Voltage Range Equal to the Power Supply Voltage.
- Wide Power Supply Voltage Range and Signal Power Supply
: Single Supply $3V_{DC}$ to $36V_{DC}$ Dual Supplies $\pm 1.5V_{DC}$ to $\pm 18V_{DC}$
- Large Output Voltage Swing : $0V_{DC}$ to $V_{CC}-1.5V_{DC}$
- Low Input Biasing Current : $I_I=45nA_{DC}$ (Typ.)
- Possible to Exchange the Position of Pin ⑨ for Pin ① Because of Pin Connection Being Symmetric. (KIA358S only)
- The Pin ① and Pin ⑨ of Lead Frame was Each Other Connected. (KIA358S Only)

勝特力材料 886-3-5753170
 勝特力电子(上海) 86-21-54151736
 勝特力电子(深圳) 86-755-83298787
[Http://www.100y.com.tw](http://www.100y.com.tw)

PIN CONNECTION (TOP VIEW)

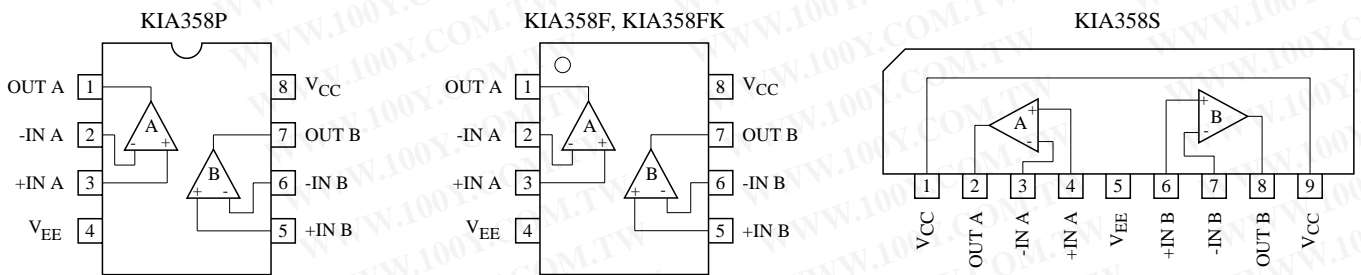

MARKING

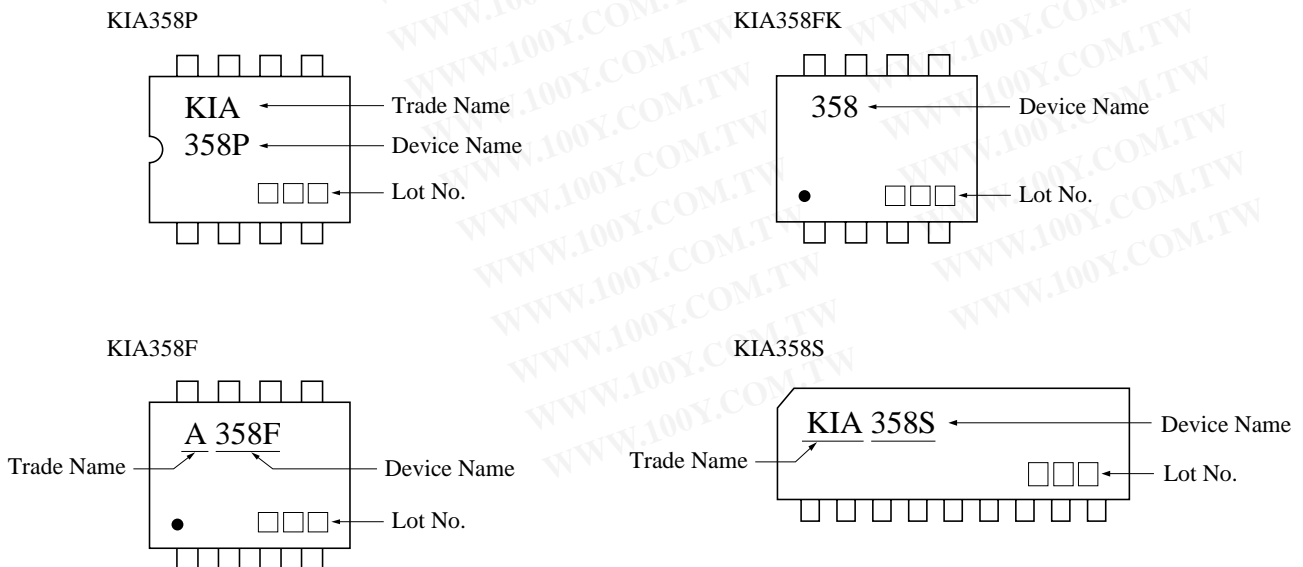

KIA358P/S/F/FK

EQUIVALENT CIRCUIT

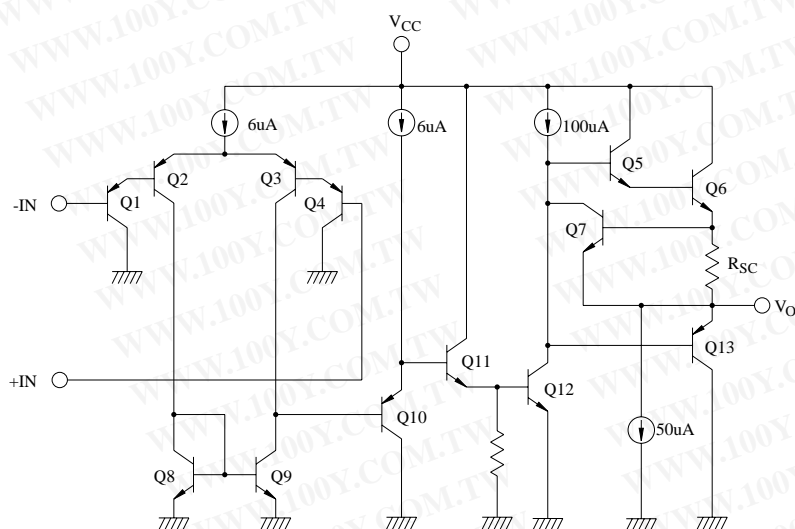

勝特力材料 886-3-5753170
 勝特力电子(上海) 86-21-54151736
 勝特力电子(深圳) 86-755-83298787
[Http://www.100y.com.tw](http://www.100y.com.tw)

MAXIMUM RATINGS (Ta=25 °C)

CHARACTERISTIC		SYMBOL	RATING	UNIT	
Supply Voltage		V _{CC}	36, +18	V	
		V _{EE}	0, -18		
Differential Input Voltage		DV _{IN}	±36	V	
Input Voltage		V _{IN}	-0.3 ~ 36	V	
Power Dissipation	KIA358P/S	P _D	500	mW	
	KIA358F		280		
	KIA358FK		200		
Operating Temperature		T _{opr}	-40 ~ 85	°C	
Storage Temperature		T _{stg}	-55 ~ 125	°C	
Pin ① to Pin ⑨ Maximum Current		KIA358S	I _{max}	1	A

ELECTRICAL CHARACTERISTICS (V_{CC}=5V, V_{EE}=GND, Ta=25 °C)

CHARACTERISTIC	SYMBOL	TEST CONDITION	MIN.	TYP.	MAX.	UNIT
Input Offset Voltage	V _{IO}	R _g ≤ 10k Ω	-	2	7	mV
Input Offset Current	I _{IO}	-	-	5	30	nA
Input Bias Current	I _I	-	-	45	150	nA
Common Mode Input Voltage	CMV _{IN}	V _{CC} =30V, V _{EE} =GND	0	-	V _{CC} -1.5	V
Supply Current	I _{CC} , I _{EE}	R _L =∞, All OP Amps	-	0.7	1.2	mA
Voltage Gain	G _V	R _L ≥ 2k Ω	86	100	-	dB
Maximum Output Voltage Swing	V _{OP-P}	R _L =2k Ω	0	V _{CC} -1.5	-	V
Common Mode Input Signal Rejection Ratio	CMRR	-	60	85	-	dB
Supply Voltage Rejection Ratio	SVRR	R _g =10k Ω	60	100	-	dB
Source Current	I _{source}	-IN=0V _{DC} , +IN=1V _{DC}	20	40	-	mA
Sink Current	I _{sink}	-IN=1V _{DC} , +IN=0V _{DC}	10	20	-	mA

KIA358P/S/F/FK

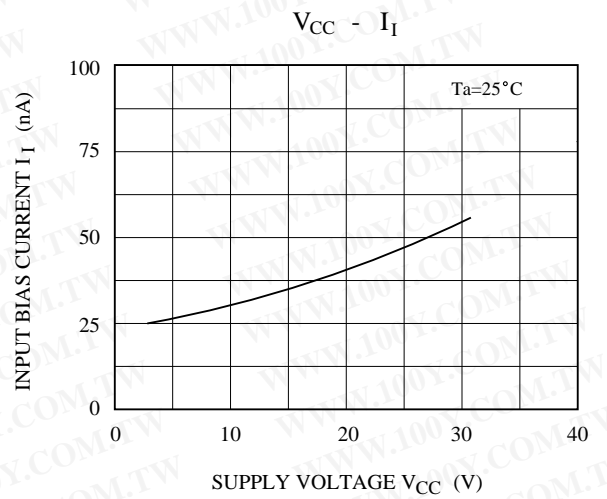
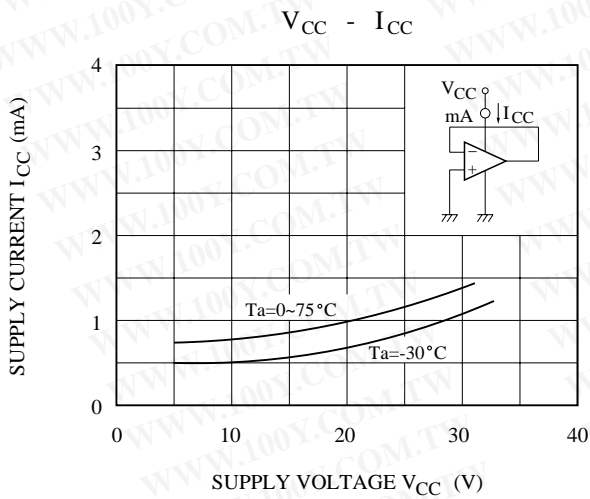

勝特力材料 886-3-5753170
 勝特力电子(上海) 86-21-54151736
 勝特力电子(深圳) 86-755-83298787
[Http://www.100y.com.tw](http://www.100y.com.tw)

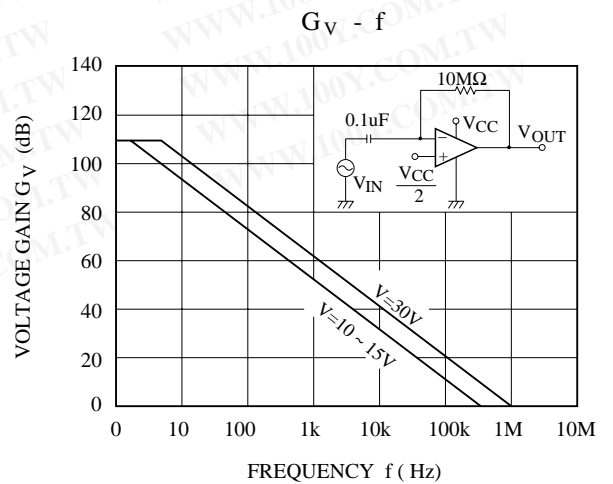
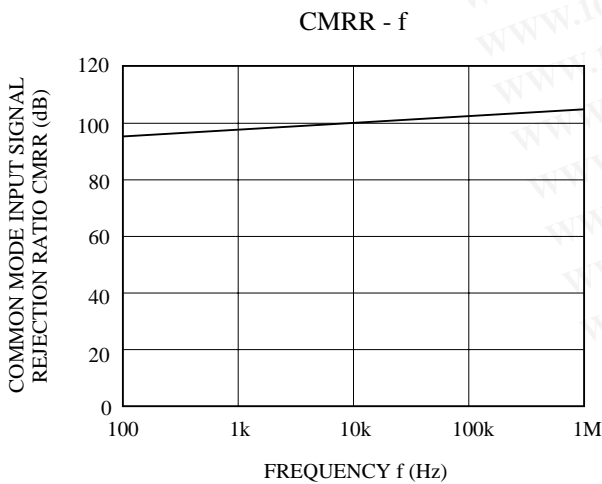
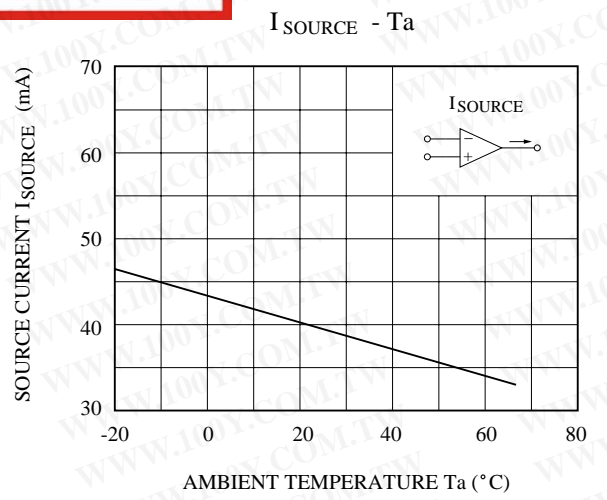
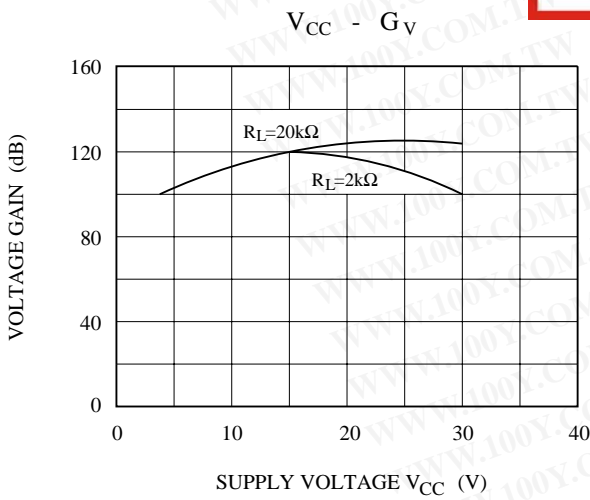

KIA358P/S/F/FK

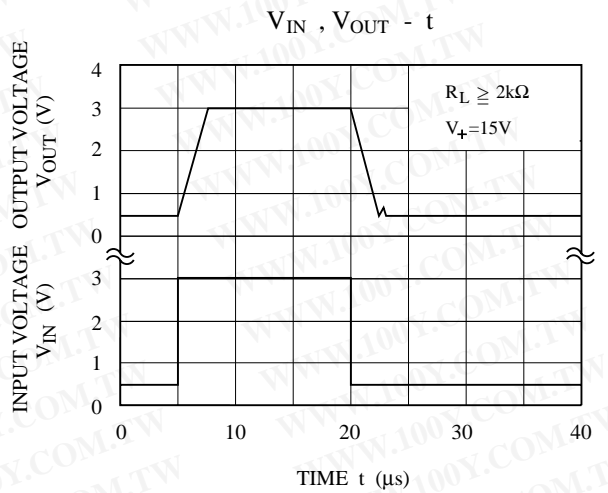
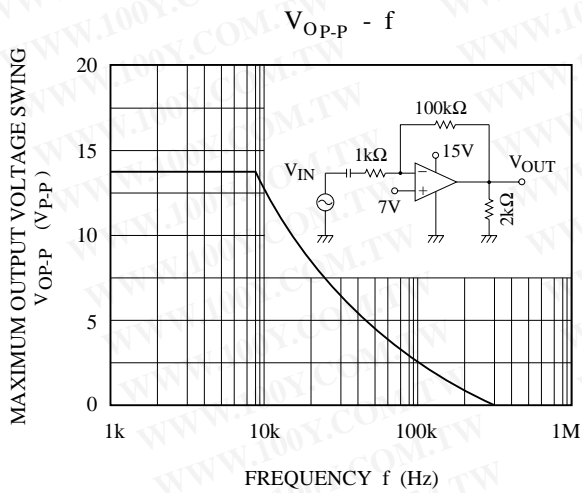

勝特力材料 886-3-5753170
 勝特力电子(上海) 86-21-54151736
 勝特力电子(深圳) 86-755-83298787
[Http://www.100y.com.tw](http://www.100y.com.tw)

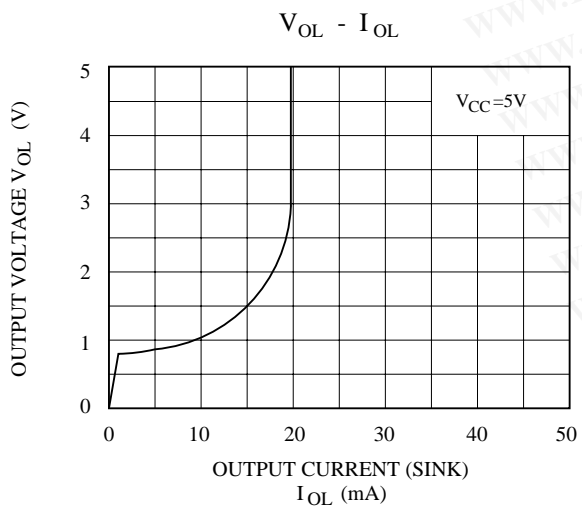
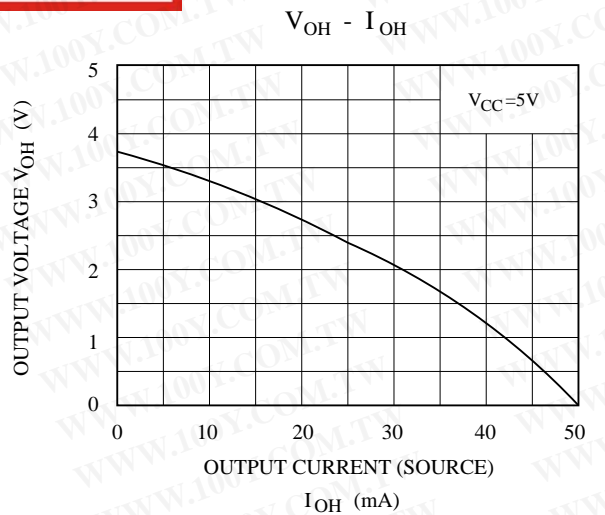
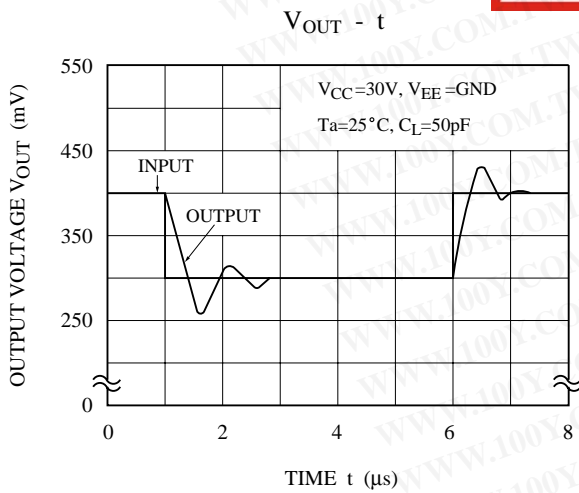

KIA358P/S/F/FK

