

## POWER MANAGEMENT

### 3-Pin Microcontroller Power Supply Supervisor

The IMP809/IMP810 are 3.0V, 3.3V and 5.0V power supply supervisor circuits optimized for low-power microprocessor ( $\mu\text{P}$ ), microcontroller ( $\mu\text{C}$ ) and digital systems. The IMP809/810 are improved drop-in replacements for the Maxim MAX809/810 and feature 60% lower supply current.

A reset signal is issued if the power supply voltage drops below a preset reset threshold and is asserted for at least 140ms after the supply has risen above the reset threshold. The IMP809 has an active-low RESET output that is guaranteed to be in the correct state for  $V_{\text{CC}}$  down to 1.1V. The IMP810 has an active-high RESET output. The reset comparator is designed to ignore fast transients on  $V_{\text{CC}}$ .

Low supply current makes the IMP809/IMP810 ideal for use in portable and battery operated equipment. The IMP809/IMP810 are available in a compact 3-pin SOT23 package.

Six voltage thresholds are available to support 3V to 5V systems:

Reset Threshold	
Suffix	Voltage (V)
L	4.63
M	4.38
J	4.00
T	3.08
S	2.93
R	2.63

#### Key Features

- ◆ Improved Maxim MAX809/MAX810 replacement
  - Lower supply current...6 $\mu\text{A}$
  - 80% lower maximum supply current
- ◆ Monitor 5V, 3.3V and 3V supplies
- ◆ 140ms min. reset pulse width
- ◆ Active-low reset valid with 1.1V supply (IMP809)
- ◆ Small 3-pin SOT-23 package
- ◆ No external components
- ◆ Specified over full temperature range
  - $-40^{\circ}\text{C}$  to  $105^{\circ}\text{C}$

#### Applications

- ◆ Embedded controllers
- ◆ Battery operated systems
- ◆ Intelligent instruments
- ◆ Wireless communication systems
- ◆ PDAs and handheld equipment

#### Block Diagrams

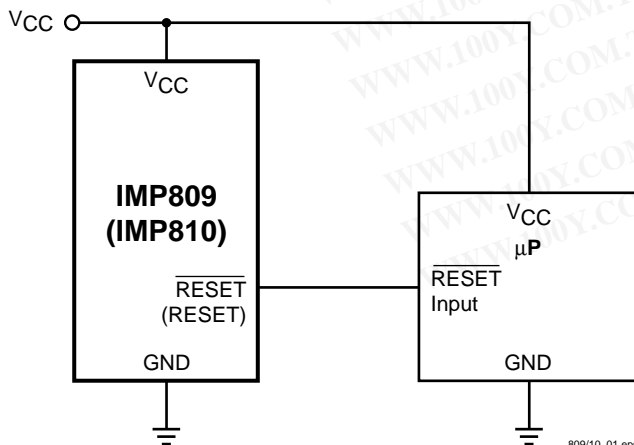

## Pin Configuration

SOT23

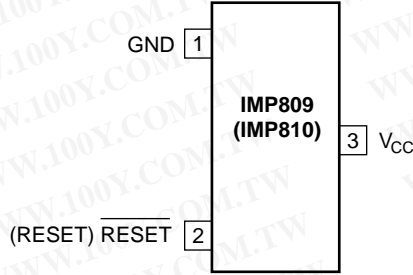

809/10\_02.eps

## Ordering Information

Part Number <sup>1</sup>	Reset Threshold (V)	Temperature Range	Pin-Package	Package Marking <sup>2</sup> (XX Lot Code)
<b>IMP809 Active LOW Reset</b>				
IMP809LEUR-T	4.63	-40°C to +105°C	3-SOT23	AAXX
IMP809MEUR-T	4.38	-40°C to +105°C	3-SOT23	ABXX
IMP809JEUR-T	4.00	-40°C to +105°C	3-SOT23	CWXX
IMP809TEUR-T	3.08	-40°C to +105°C	3-SOT23	ACXX
IMP809SEUR-T	2.93	-40°C to +105°C	3-SOT23	ADXX
IMP809REUR-T	2.63	-40°C to +105°C	3-SOT23	AFXX
<b>IMP810 Active HIGH Reset</b>				
IMP810LEUR-T	4.63	-40°C to +105°C	3-SOT23	AGXX
IMP810MEUR-T	4.38	-40°C to +105°C	3-SOT23	AHXX
IMP810JEUR-T	4.00	-40°C to +105°C	3-SOT23	AIXX
IMP810TEUR-T	3.08	-40°C to +105°C	3-SOT23	AJXX
IMP810SEUR-T	2.93	-40°C to +105°C	3-SOT23	AKXX
IMP810REUR-T	2.63	-40°C to +105°C	3-SOT23	ALXX

Notes: 1. Tape and Reel packaging is indicated by the -T designation.  
 2. Devices may also be marked with full part number: 809L, 810M etc. XX refers to lot.

## Related Products

	IMP809	IMP810	IMP811	IMP812
Max. Supply Current	15µA	15µA	15µA	15µA
Package Pins	3	3	4	4
Manual RESET input			■	■
Package Type	SOT-23	SOT-23	SOT-143	SOT-143
Active-HIGH RESET output		■		■
Active-LOW RESET output	■		■	

## Absolute Maximum Ratings

### Pin Terminal Voltage with Respect to Ground

$V_{CC}$ .....	-0.3V to 6.0V
RESET, $\overline{\text{RESET}}$ .....	-0.3V to ( $V_{CC} + 0.3V$ )
Input Current at $V_{CC}$ .....	20mA
Output Current: RESET, $\overline{\text{RESET}}$ .....	20mA
Rate of Rise at $V_{CC}$ .....	100V/ $\mu$ s

Power Dissipation ( $T_A = 70^\circ\text{C}$ ) .....	320mW
(Derate 4mW/ $^\circ\text{C}$ above 70 $^\circ\text{C}$ )	
Operating Temperature Range .....	-40 $^\circ\text{C}$ to 105 $^\circ\text{C}$
Storage Temperature Range .....	-65 $^\circ\text{C}$ to 160 $^\circ\text{C}$
Lead Temperature (soldering, 10 sec) .....	300 $^\circ\text{C}$

These are stress ratings only and functional operation is not implied.  
 Exposure to absolute maximum ratings for prolonged time periods may affect device reliability

## Electrical Characteristics

Unless otherwise noted  $V_{CC}$  is over the full voltage range,  $T_A = -40^\circ\text{C}$  to 105 $^\circ\text{C}$ .

Typical values at  $T_A = 25^\circ\text{C}$ ,  $V_{CC} = 5V$  for L/M/J devices,  $V_{CC} = 3.3V$  for T/S devices and  $V_{CC} = 3V$  for R devices.

Parameter	Symbol	Conditions	Min	Typ	Max	Units	
Input Voltage ( $V_{CC}$ ) Range	$V_{CC}$	$T_A = 0^\circ\text{C}$ to 70 $^\circ\text{C}$ $T_A = -40^\circ\text{C}$ to 105 $^\circ\text{C}$	1.1 1.2		5.5 5.5	V	
Supply Current	$I_{CC}$	$T_A = -40^\circ\text{C}$ to 85 $^\circ\text{C}$ $T_A = -40^\circ\text{C}$ to 85 $^\circ\text{C}$ $T_A = 85^\circ\text{C}$ to 105 $^\circ\text{C}$ $T_A = 85^\circ\text{C}$ to 105 $^\circ\text{C}$	$V_{CC} < 5.5V$ , L/M/J $V_{CC} < 3.6V$ , R/S/T $V_{CC} < 5.5V$ , L/M/J $V_{CC} < 3.6V$ , R/S/T	9 6	15 10 25 20	$\mu$ A	
Reset Threshold	$V_{TH}$	L devices M devices J devices T devices S devices R devices	$T_A = 25^\circ\text{C}$ $T_A = -40^\circ\text{C}$ to 85 $^\circ\text{C}$ $T_A = 85^\circ\text{C}$ to 105 $^\circ\text{C}$ $T_A = 25^\circ\text{C}$ $T_A = -40^\circ\text{C}$ to 85 $^\circ\text{C}$ $T_A = 85^\circ\text{C}$ to 105 $^\circ\text{C}$ $T_A = 25^\circ\text{C}$ $T_A = -40^\circ\text{C}$ to 85 $^\circ\text{C}$ $T_A = 85^\circ\text{C}$ to 105 $^\circ\text{C}$ $T_A = 25^\circ\text{C}$ $T_A = -40^\circ\text{C}$ to 85 $^\circ\text{C}$ $T_A = 85^\circ\text{C}$ to 105 $^\circ\text{C}$ $T_A = 25^\circ\text{C}$ $T_A = -40^\circ\text{C}$ to 85 $^\circ\text{C}$ $T_A = 85^\circ\text{C}$ to 105 $^\circ\text{C}$	4.56 4.50 4.40 4.31 4.25 4.16 3.93 3.89 3.80 3.04 3.00 2.92 2.89 2.85 2.78 2.59 2.55 2.50	4.63 4.38 4.00 3.08 2.93 2.63	4.70 4.75 4.86 4.45 4.50 4.56 4.06 4.10 4.20 3.11 3.15 3.23 2.96 3.00 3.08 2.66 2.70 2.76	V
Reset Threshold Stability				30		ppm/ $^\circ\text{C}$	
$V_{CC}$ to Reset Delay		$V_{CC} = V_{TH}$ to $V_{TH} - 100\text{mV}$		20		$\mu$ s	
Reset Active Timeout Period	$V_{OL}$	$T_A = -40^\circ\text{C}$ to 85 $^\circ\text{C}$ $T_A = 85^\circ\text{C}$ to 105 $^\circ\text{C}$	140 100	240	560 840	ms	
Low RESET Output Voltage (IMP809)	$V_{OL}$	$V_{CC} = V_{TH}$ min., $I_{SINK} = 1.2\text{mA}$ , IMP809R/S/T $V_{CC} = V_{TH}$ min., $I_{SINK} = 3.2\text{mA}$ , IMP809L/M/J $V_{CC} > 1.1V$ , $I_{SINK} = 50\mu\text{A}$			0.3 0.4 0.3	V	
High $\overline{\text{RESET}}$ Output Voltage (IMP809)	$V_{OH}$	$V_{CC} > V_{TH}$ max., $I_{SOURCE} = 500\mu\text{A}$ , IMP809R/S/T $V_{CC} > V_{TH}$ max., $I_{SOURCE} = 800\mu\text{A}$ , IMP809L/M/J	$0.8V_{CC}$ $V_{CC} - 1.5$			V	
Low RESET Output Voltage (IMP810)	$V_{OL}$	$V_{CC} = V_{TH}$ max., $I_{SINK} = 1.2\text{mA}$ , IMP810R/S/T $V_{CC} = V_{TH}$ max., $I_{SINK} = 3.2\text{mA}$ , IMP810L/M/J			0.3 0.4	V	
High RESET Output Voltage (IMP810)	$V_{OH}$	$1.8V < V_{CC} < V_{TH}$ min., $I_{SOURCE} = 150\mu\text{A}$	$0.8V_{CC}$			V	

Notes: 1. Production testing done at  $T_A = 25^\circ\text{C}$ . Over-temperature specifications guaranteed by design only.  
 2.  $\overline{\text{RESET}}$  output is active LOW for the IMP809 and RESET output is active HIGH for the IMP810

## Pin Descriptions

Pin Number	Name	Function
1	GND	Ground
2 (IMP809)	$\overline{\text{RESET}}$	RESET is asserted LOW if $V_{CC}$ falls below the reset threshold and remains LOW for the 240ms typical reset timeout period (140ms minimum) after $V_{CC}$ exceeds the threshold.
2 (IMP810)	RESET	RESET is asserted HIGH if $V_{CC}$ falls below the reset threshold and remains HIGH for the 240ms typical reset timeout period (140ms minimum) after $V_{CC}$ exceeds the threshold.
3	$V_{CC}$	Power supply input voltage (3.0V, 3.3V, 5.0V)

## Detailed Descriptions

### Reset Timing

The reset signal is asserted–LOW for the IMP809 and HIGH for the IMP810–when the  $V_{CC}$  signal falls below the threshold trip voltage and remains asserted for 140ms minimum after the  $V_{CC}$  has risen above the threshold.

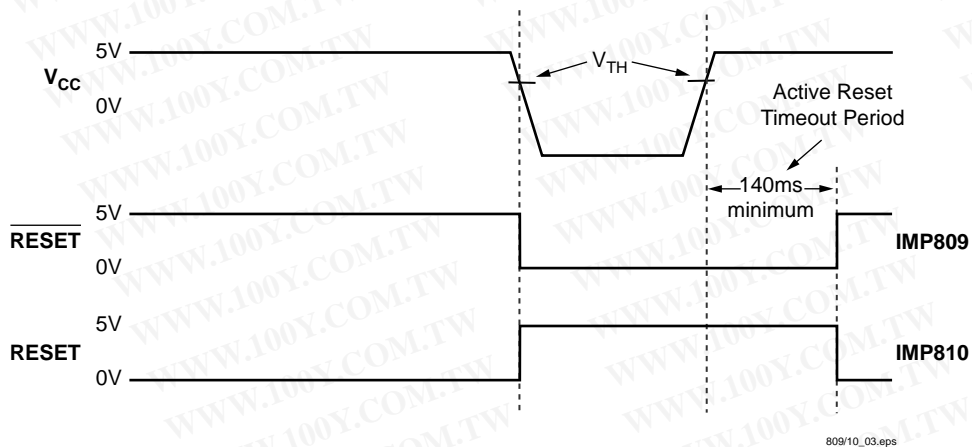

Figure 1. Reset Timing Diagram

### Negative V<sub>CC</sub> Transients

The IMP809/810 protect  $\mu$ P's from brownouts and low V<sub>CC</sub>. Short duration transients of 100mV amplitude and 20 $\mu$ s or less duration typically do not cause a false RESET.

### Valid Reset with V<sub>CC</sub> under 1.1V

To ensure logic inputs connected to the IMP809  $\overline{\text{RESET}}$  pin are in a known state when V<sub>CC</sub> is under 1.1V, a 100k $\Omega$  pull-down

resistor at  $\overline{\text{RESET}}$  is needed. The value is not critical. A pull-up resistor to V<sub>CC</sub> is needed with the IMP810.

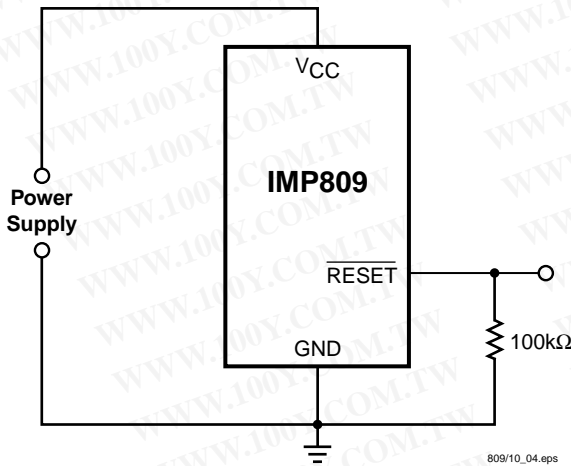

Figure 2.  $\overline{\text{RESET}}$  Valid with V<sub>CC</sub> Under 1.1V

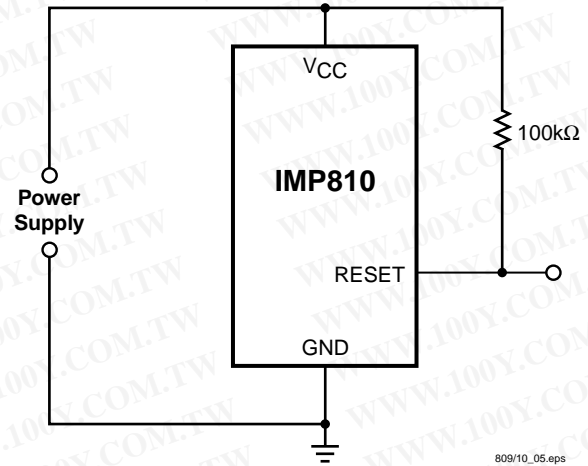

Figure 3. RESET Valid with V<sub>CC</sub> Under 1.1V

### Bi-directional Reset Pin Interfacing

The IMP809/810 can interface with  $\mu$ P/ $\mu$ C bi-directional reset pins by connecting a 4.7k $\Omega$  resistor in series with the IMP809/810 reset output and the  $\mu$ P/ $\mu$ C bi-directional reset pin.

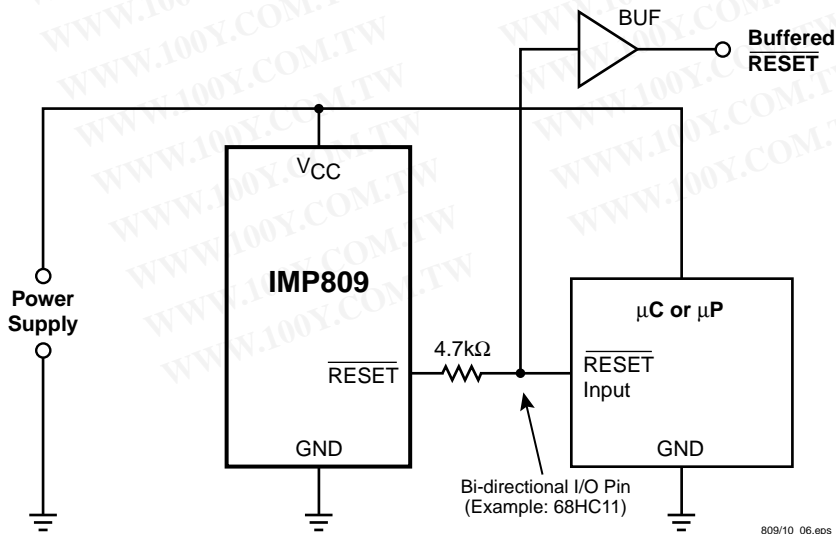
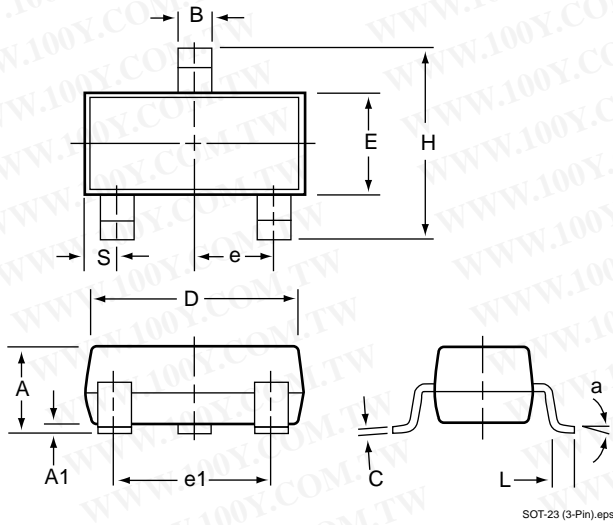

Figure 4. Bi-directional Reset Pin Interfacing

Package Dimensions

Plastic SOT-23 (3-Pin)



	Inches		Millimeters	
	Min	Max	Min	Max
<b>Plastic SOT-23 (3-Pin)</b>				
A	0.031	0.050	0.80	1.27
A1	0.004	0.010	0.10	0.25
B	0.015	0.020	0.37	0.51
C	0.003	0.007	0.085	0.18
D	0.110	0.120	2.80	3.04
E	0.047	0.055	1.20	1.40
e	0.035	0.040	0.89	1.03
e1	0.070	0.080	1.78	2.05
H	0.083	0.1039	2.10	2.64
L	0.027 REF		0.069 REF	
S	0.018	0.024	0.45	0.60